

STANDARD-STIRNRADGETRIEBE

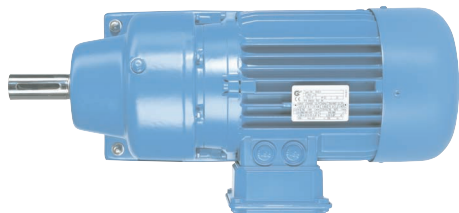
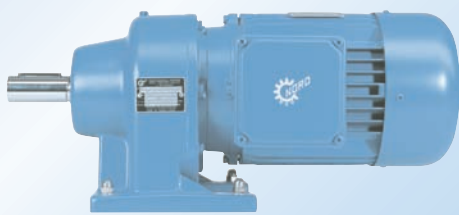

**Standard
Helical Gearboxes**

**Réducteurs à engrenages
cylindriques standards**

Verstellgetriebe

Variable Speed Drives

**Variateurs mécaniques
à courroie**



G 2000 DE GB FR





Kapitel Chapter Chapitre	Inhalt Contents Contenu	Seite Page Page
--------------------------------	-------------------------------	-----------------------

**TECHNISCHE ERLÄUTERUNGEN
EXPLANATORY NOTES
DESCRIPTIONS TECHNIQUES**

Getriebebeschreibung / Engineering data / Description du réducteur

Stirradgetriebe / Helical Gearboxes / Réducteurs à engrenages cylindriques	2
--	---

**GETRIEBEAUSWAHL
SELECTION PROCEDURES
CHOIX DU REDUCTEUR**

Beispiele für Belastungsart von Getrieben / Type of loading for gearboxes / Quelques application d'utilisation de réducteurs	2
---	---

Max. zulässige Abtriebsdrehmomente Permissible output torques Couple max. Admissible de sortie	3
--	---

Zulässige Querkraft / Axialkraft Antriebswelle Permissible overhung loads / axial loads input shaft Charges radiales admissibles / axiales admissibles sur l'arbre d'entrée	4
---	---

Abtriebswelle verstärkt Output shaft reinforced Arbre de sortie renforce	5
--	---

Lieferbare Ausführungen / Available designs / Exécution livrables	6
---	---

Bauformen / Mounting positions / Positions de montage	7
---	---

Schmierung / Lubrication / Lubrification	8
--	---

Hinweise zu den Maßbildern / Notes appertaining to the dimension sheets / Remarques concernant les feuilles de cotes	10
---	----



**STIRNRADGETRIEBEMOTOREN
HELICAL GEARED MOTORS
MOTOREDUCTEURS A ENGRENAGES CYLINDRIQUES**

Leistungs- Drehzahlübersicht / Performances / Tableau des puissances

4 polig / 4 poles / 4 pôles	11
-----------------------------	----

4-2 polig / 4-2 poles / 4-2 pôles	28
-----------------------------------	----

Maßblätter / Dimension sheets / Cotes d'encombrement

	42
--	----

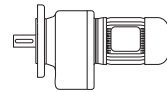
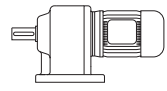

**STIRNRADGETRIEBE
HELICAL GEAR UNITS
REDUCTEURS A ENGRENAGES CYLINDRIQUES**

**Leistungs- und Übersetzungstabellen / Table of performances and reductions /
Tableau des puissances et des réductions**

	46
--	----

Maßblätter / Dimension sheets / Cotes d'encombrement

Typ W / Type W / Type W	54
-------------------------	----

Typ IEC / Type IEC / Type IEC	58
-------------------------------	----

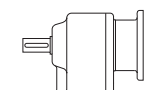
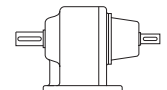

**STIRNRADGETRIEBE - OPTIONEN
HELICAL GEAR UNITS - OPTIONS
REDUCTEURS A ENGRENAGES CYLINDRIQUES - OPTIONS**

Fuß/Flanschausführung (B3/B14 , B3/B5) / Foot/Flange mounting (B3/B14 , B3/B5) / Exécution a pattes et brides (B3/B14 , B3/B5) mit antriebsseitigem Flansch / with flange on input side / avec bride cote entrainement	62
--	----

Lieferbare Flansche / Available flanges / Brides livrables	63
--	----



Kapitel Chapter Chapitre	Inhalt Contents Contenu	Seite Page Page	
MOTOREN / MOTORS / MOTEURS			
	Technische Erläuterungen / Explanatory notes / Description techniques	64	
EINPHASENMOTOREN / SINGLE PHASE MOTORS / MOTEURS MONOPHASES			
	Motorabmessungen / Motor dimensions / Dimensions des moteur	68	
BREMSEN / BRAKES / FREINS			
	Technische Erläuterungen / Explanatory notes / Description techniques	69	
	Maßänderung durch Bremsmotorenanbau For additional dimensions with brake-motors Pour les moteurs frein voir modifications de cotes	69	
STIRNRAD - VERSTELLGETRIEBEMOTOREN VARIABLE SPEED HELICAL GEARED MOTORS MOTOVARIATEURS-REDUCTEURS A ENGRENAGES CYLINDRIQUES			
	Technische Erläuterungen Explanatory notes Description techniques		
	Getriebebeschreibung / Engineering data / Description du réducteur	71	
	Antriebsauslegung / Selection / Choix du réducteur	71	
	Verstellungen / Speed controls / Réglages	72	
	Keilriemenwechsel / Replacement of V-Belt / Remplacement de la courroie trapezoidale	73	
	Drehzahlanzeigen / Speed indicators / Indicateurs de vitesse	74	
	Motoranbau / Motor attachment / Montage moteurs	76	
	Lieferbare Ausführungen / Available designs / Exécution livrables	77	
	Bauformen / Mounting positions / Position de montage	78	
	Leistungs- Drehzahlübersicht / Performances / Tableau des puissances		
	4 polig / 4 poles / 4 pôles	79	
	Maßblätter / Dimension sheets / Cotes d'encombrement		
	U - Ausführung / U - design / Exécution U	88	
	Z - Ausführung / Z - design / Exécution Z	90	
ALLGEMEINE ERSATZTEILE GENERAL PARTS LISTS LISTE GENERAL DE PIECES DETACHEES			
		92	

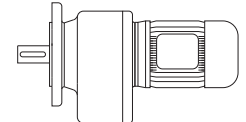
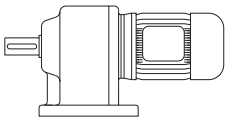

GETRIEBEAUSWAHL
SELECTION PROCEDURE
CHOIX DU REDUCTEUR

GETRIEBEBESCHREIBUNG
Standard - Stirnradgetriebe

Sechs Baugrößen in zwei- und dreistufiger Ausführung, als Fuß- oder Flanschgetriebe bzw. -getriebemotoren decken den Leistungsbereich von 0,12 bis 7,50 kW und den Drehmomentenbereich von 50 bis 700 Nm ab.

GETRIEBEAUSWAHL

Kriterien für die Auswahl der Getriebe werden bestimmt durch:

die mechanische Leistung - diese wird im Katalog in der entsprechenden Tabelle durch den f_B Faktor berücksichtigt

Für den jeweiligen Antriebsfall wird durch Messung oder Berechnung die erforderliche Motorleistung bestimmt. Der Motor ist nach dieser Leistung auszuwählen, wobei kurzzeitige Drehmomentenstöße für die Motorleistung unberücksichtigt bleiben.

Dagegen ist für das Getriebe die Belastungsart von besonderer Bedeutung. Mit Hilfe des Massenbeschleunigungsfaktors m_{af} und der Schalthäufigkeit, kann für eine bestimmte Laufzeit der erforderliche Betriebsfaktor f_B bestimmt werden.

Beispiele für Belastungsart von Getrieben und Getriebemotoren:

- A** Leichte Förderschnecken, Lüfter, Montagebänder, leichte Transportbänder, Kleinrührwerke, Elevatoren, Reinigungsmaschinen, Abfüllmaschinen, Kontrollmaschinen, Gurtförderer.
- B** Haspeln, Vorschubantriebe für Holzbearbeitungsmaschinen, Lastaufzüge, Auswuchtmaschinen, Gewindeeinheiten, mittlere Rührer und Mischer, schwere Transportbänder, Winden, Schiebetore, Stalletmistungen, Verpackungsmaschinen, Betonmischer, Kranfahrwerke, Mühlen, Biegegeräte, Zahnradschnecken.
- C** Schwere Mischer, Scheren, Pressen, Zentrifugen, Walzwerke, schwere Winden und Aufzüge, Kollergänge, Steinbrecher, Becherwerke, Stanzen, Hammermühlen, Exzenterpressen, Abkantmaschinen, Rollgänge, Putz- und Scheuertrommeln, Rüttelvorrichtungen, Zerkleinerungsmaschinen.

Andere Maschinen sind, gemäß ihrer Belastungsart, den drei Gruppen zuzuordnen.

Der Getriebebetriebsfaktor ist der Quotient aus dem maximalen Getriebedrehmoment und dem Abtriebsmoment aus Leistung und Drehzahl.

$$\text{Abtriebsdrehmoment } M_a = \frac{9550 \cdot P}{n_2} \text{ [Nm]} \quad P \text{ [kW]} \quad n_2 \text{ [min}^{-1}\text{]}$$

$$\text{Getriebebetriebsfaktor } f_B = \frac{M_{a \text{ max}}}{M_a}$$

Bei richtiger Getriebeauswahl muß der aus der Kurve ermittelte Betriebsfaktor immer kleiner oder höchstens gleich dem Getriebebetriebsfaktor sein, der in der Leistungs-/Drehzahlübersicht bei der jeweiligen Drehzahl aufgeführt ist.

ENGINEERING DATA
Standard Helical Gearboxes

Six sizes are available in double- and triple - reduction design as foot- or flange - mount units. These drives cover the power range from 0,12 to 7,50 kW with torque capacities of 50 to 700 Nm.

SELECTION PROCEDURES

Criteria for selection of the gearboxes are:

mechanical power - service factor f_B shown in the tables in the catalog

Each application requires either the calculation or the measurement of the required motor power. Base the motor selection on the above power requirement. Intermittent shock loading should not be considered for motor power selection.

On the other hand, it is important to consider the type of loading when selecting the gearbox size. The service factor f_B can be determined by the parameters: mass-acceleration-factor m_{af} , cycles / hour and the operating time.

Type of loading for gearboxes and geared motors:

- A** Light conveyor screws, fans, assembly lines, light conveyor belts, small agitators, elevators, cleaning machines, filling machines, inspection machines, belt conveyors.
- B** Coilers, feed-mechanism drives for woodworking machines, dumbwaiters, balancing machines, thread cutting machines, medium sized agitators and mixers, heavy conveyor belts, winches, sliding doors, manure scrapers, packing machines, concrete mixers, crane traveling mechanisms, mills, bending machines, gear pumps.
- C** Heavy mixers, shears, presses, centrifuges, rolling stands, heavy winches and lifts, grinding mills, stone crushers, bucket elevators, punching machines, hammer mills, eccentric presses, folding machines, roller tables, tumbling barrels, vibrators, shredders.

Other machines should be associated to one of the three groups, depending on the type of load they represent.

The service factor is the quotient of the maximum permissible output torque and the nominal output torque where by the nominal output torque is defined as the quotient of power and output speed.

$$\text{Output torque } M_a = \frac{9550 \cdot P}{n_2} \text{ [Nm]} \quad P \text{ [kW]} \quad n_2 \text{ [min}^{-1}\text{]}$$

$$\text{Service factor } f_B = \frac{M_{a \text{ max}}}{M_a}$$

To select the correct gearbox the service factor taken from the diagram must be less than or at maximum equal the service factor which is listed in the selection charts at the appropriate speed.

DESCRIPTION DU REDUCTEUR
Réducteur standard à engrenages cylindriques

Six série est déclinée en version deux et trois étages, en version réducteur seul ou motoréducteur, avec pattes ou bride et couvrant une plage de 0,12 à 7,50 kW et une plage de couple de 50 à 700 Nm.

CHOIX DU REDUCTEUR

Les critères pour la sélection du réducteur se fait de la manière suivante:

la puissance mécanique - celle-ci sera déterminée dans les tableaux du catalogue en fonction du facteur f_B .

Pour chaque cas d'entraînement, on détermine par des mesures ou des calculs, la puissance du moteur nécessaire. Le moteur doit être choisi avec cette puissance calculée, applicable à un fonctionnement régulier sans à-coups.

Par contre, le facteur de service est très important pour le réducteur. A l'aide du facteur d'accélération de masses m_{af} et de la fréquence de démarrage on peut définir, pour une certaine durée d'utilisation, le facteur de fonctionnement nécessaire f_B .

Quelques applications d'utilisation de réducteurs et motoréducteurs:

- A** Petits vis de transport, ventilateurs, chaînes de montage, petits tapis roulants, petits agitateurs, élévateurs, nettoyeurs, embouteilleuses, machines de contrôle, transporteurs à bande.
- B** Dévidoirs, appareils d'alimentation pour machines à bois, monte-charge, équilibreuses, unités de filetage, agitateurs, mélangeurs moyens, tapis roulants lourds, treuils, portes coulissantes, évacuateurs de fumier de ferme, machines à emballer, bétonneuses, grues, broyeurs, machines à cintrer, pompes à engrenages.
- C** Mélangeurs lourds, cisailles, presses, centrifugeuses, laminoirs, treuils lourds et élévateurs, broyeurs à meules, concasseurs, chaînes à godets, presses à estamper, broyeurs à marteaux, presses à excentrique, machines à chanfreiner, tables à rouleaux, tambours de nettoyage ou de dessablage, vibreurs, machines à broyer.

Tout autre type de machine est à rattacher à l'un de ces 3 groupes, selon son facteur d'utilisation. Le facteur de service du réducteur est le quotient résultant du couple maximum de sortie et du couple nominal qui se calcule à partir de la puissance et de la vitesse.

$$\text{Couple nominal du réducteur } M_a = \frac{9550 \cdot P}{n_2} \text{ [Nm]} \quad P \text{ [kW]} \quad n_2 \text{ [min}^{-1}\text{]}$$

$$\text{Facteur de service du réducteur } f_B = \frac{M_{a \text{ max}}}{M_a}$$

Pour un choix du réducteur correct, le facteur de service déterminé d'après la courbe, doit toujours être plus petit ou au moins égal au facteur de service du réducteur indiqué dans le tableau des puissances/vitesses.

TECHNISCHE ERLÄUTERUNGEN / EXPLANATORY NOTES / DESCRIPTIONS TECHNIQUES

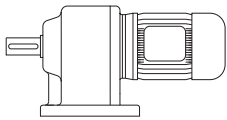

GETRIEBEAUSWAHL SELECTION PROCEDURES CHOIX DU REDUCTEUR

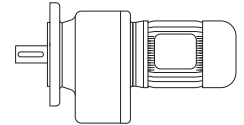

Max. zulässige Abtriebsdrehmomente / Max. permissible output torque / Couple max. admissible de sortie						
Typ / Type / Type	SK 0 SK 05	SK 01, SK 010 SK 015, SK 0105	SK 20, SK 200 SK 205, SK 2005	SK 25, SK 250 SK 255, SK 2505	SK 30, SK 300 SK 305, SK 3005	SK 33, SK 330 SK 335, SK 3305
M_a max [Nm]	50	100	200	300	400	700

Belastungsart

Type of loading

Facteur d'utilisation

- * Laufzeit Std. / Tag
- * Operating time hours / day
- * Durée d'utilisation heure / jour

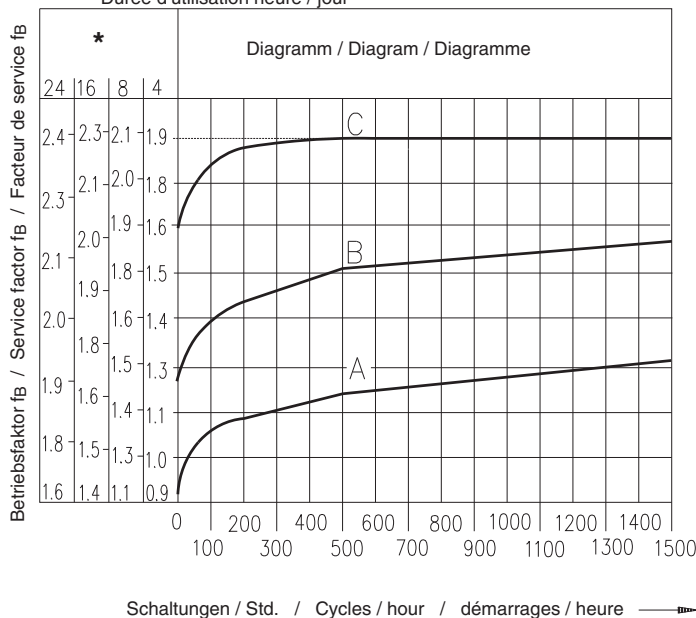

BELASTUNGSART: TYPE OF LOADING: FACTEUR D'UTILISATION: MASSENBSCHLEUNIGUNGSFAKTOR: MASS ACCELERATION FACTOR: FACTEUR D'ACCELERATION DES MASSES:

- | | | |
|----------|--|---------------------|
| A | gleichmäßiger Betrieb
uniform
fonctionnement régulier | $m_{af} \leq 0,25$ |
| B | ungleichmäßiger Betrieb
moderate shock
fonctionnement irrégulier | $m_{af} \leq 3,00$ |
| C | stark ungleichmäßiger Betrieb
heavy shock
fonctionnement très irrégulier | $m_{af} \leq 10,00$ |

$$m_{af} = \frac{I_{ex. red.}}{I_{Mot.}}$$

$I_{ex. red.}$ = alle externen Massenträgheitsmomente auf Antriebsmotor red.
all external inertia moments corrected to motor input
moment d'inertie des masses entraînées, ramené à l'arbre moteur

I_{Mot} = Massenträgheitsmoment des Antriebsmotors
moment of inertia of the motor
moment d'inertie du moteur d'entraînement

f_B = Betriebsfaktor { M_{amax} / M_a }	f_B = Service factor { M_{amax} / M_a }	f_B = Facteur de service { M_{amax} / M_a }
F_A = zulässige Axialkraft abtriebsseitig, [N]	F_A = Permissible thrust load at the output side [N]	F_A = Charge axiale admissible côte sortié [N]
F_{A1} = zulässige Axialkraft antriebsseitig, [N]	F_{A1} = Permissible thrust load at the input side [N]	F_{A1} = Charge axiale admissible sur l'arbre d'entrée [N]
F_Q = zulässige Querkraft abtriebsseitig, Kraftangriff auf Mitte Wellenende	F_Q = Permissible overhung load at the output side, force acting at the shaft's midpoint [N]	F_Q = Charge radiale admissible côte sortie, plan d'attaque à mi-bout d'arbre [N]
F_{Q1} = zulässige Querkraft antriebsseitig, Kraftangriff auf Mitte Wellenende	F_{Q1} = Permissible overhung load at the input side, force acting at the shaft's midpoint [N]	F_{Q1} = Charge radiale admissible sur l'arbre d'entrée, plan d'attaque à mi-bout d'arbre [N]
i_{ges} = Getriebeübersetzung gesamt	i_{total} = Gear units total ratio	i_{totale} = Rapport de réduction totale
M_a = Abtriebsdrehmoment [Nm]	M_a = Output torque [Nm]	M_a = Couple de sortie [Nm]
M_{amax} = maximal zulässiges Abtriebsdrehmoment [Nm]	M_{amax} = Max permissible output torque [Nm]	M_{amax} = Couple de sortie max. [Nm]
n₂ = Abtriebsdrehzahl [min ⁻¹]	n₂ = Output speed [min ⁻¹]	n₂ = Vitesse de sortie du réducteur [min ⁻¹]
P_n = Nennleistung des Motors [kW]	P_n = Rated Power of motor [kW]	P_n = Puissance d'entrée calculée du réducteur [kW]
kg = Gesamtgewicht des Getriebemotors	kg = Weight of the geared motor	kg = Poids du motoréducteur [kg]

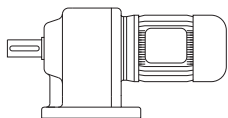

QUER- UND AXIALKRÄFTE DER ANTRIEBSWELLE
OVERHUNG AND AXIAL LOADS ON THE INPUT SHAFT
CHARGES RADIALES ET AXIALES SUR L'ARBRE D'ENTRÉE

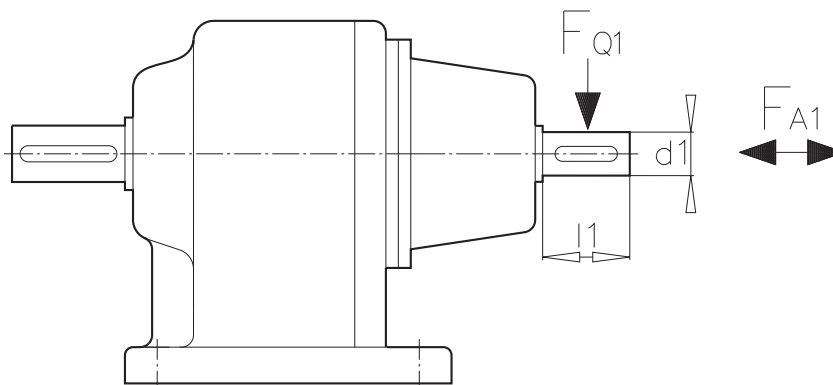
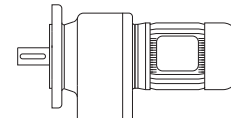

Die in den Tabellen aufgeführten Querkkräfte F_Q verstehen sich für Kraftangriff auf Mitte Wellenende = $0,5 \times l_1$.

The overhung loads F_Q in the tables relate to application of force at midpoint of shaft = $0,5 \times l_1$.

Les charges radiales F_Q , indiquées dans les tableaux ci-après s'entendent pour une force qui s'applique sur le milieu du bout d'arbre = $0,5 \times l_1$.

Antriebswelle / Input shaft / Arbre d'entrée				
Typ Type Type	Wellenmaße Shaft dimensions Cotes arbre		Zulässige Querkraft / Axialkraft F_{Q1} / F_{A1} [N] Permissible overhung load / axial load F_{Q1} / F_{A1} [N] Charges radiales admissibles / axiales admissibles F_{Q1} / F_{A1} [N] bei / at / ou	
	d1	l1	Antriebsdrehzahl n_1 / Input speed n_1 / Vitesse d'entrée n_1 1400 min ⁻¹	
			F_{Q1} / F_{A1}	
SK 0	16	40	F_{Q1} / F_{A1}	650 / 400
SK 01, SK 010, SK 200, SK 250, SK 300	16	40	F_{Q1} / F_{A1}	650 / 400
SK 20, SK 01 V, SK 250 V, SK 300 V	16	40	F_{Q1} / F_{A1}	650 / 400
SK 25, SK 30, SK 20 V, SK 330	24	50	F_{Q1} / F_{A1}	850 / 550
SK 33, SK 30 V	24	50	F_{Q1} / F_{A1}	950 / 600
SK 33 V	32	70	F_{Q1} / F_{A1}	1100 / 700

Bei den in den Tabellen aufgeführten Belastungen der An- und Abtriebswelle handelt es sich nur um Richtwerte unter Berücksichtigung des listenmäßigen Wellenzapfens und Kraftangriff auf Mitte Wellenzapfens. Genaue Berechnungen können nur unter Einbeziehung aller Faktoren im Herstellerwerk durchgeführt werden. Hierfür werden genaue Angaben über die Betriebsverhältnisse benötigt.

The loads for input and output shaft tabulated are given as an indication, taking into consideration shaft ends as mentioned in the catalogue and a force applied to the midpoint of the shaft. Precise calculation can be made at the manufacturer's works only when all factors have been given due consideration. To do so, precise information on operating conditions is required.

Les charges sur l'arbre de sortie et l'arbre d'entrée mentionnées ci-après ne sont que des valeurs indicatives, qui tiennent compte du bout d'arbre de série et de la force d'appui sur le milieu du bout d'arbre. Des calculs précis ne peuvent être faits par le fabricant qu'en prenant en considération tous les facteurs. Pour cela il faut que des indications précises soient fournies sur les conditions de fonctionnement.

TECHNISCHE ERLÄUTERUNGEN / EXPLANATORY NOTES / DESCRIPTIONS TECHNIQUES

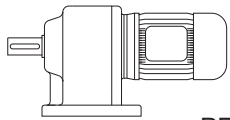

STIRNRADGETRIEBE MIT VERSTÄRKTEN ABTRIEBSWELLEN HELICAL GEARBOXES WITH REINFORCED OUTPUT SHAFTS REDUCTEURS A ENGRENAGES CYLINDRIQUES AVEC ARBRE DE SORTIE RENFORCE

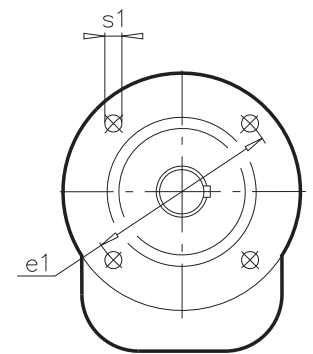
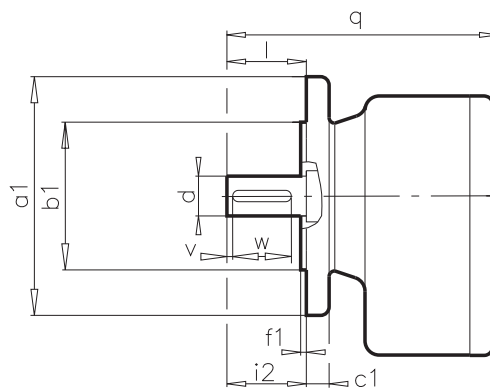
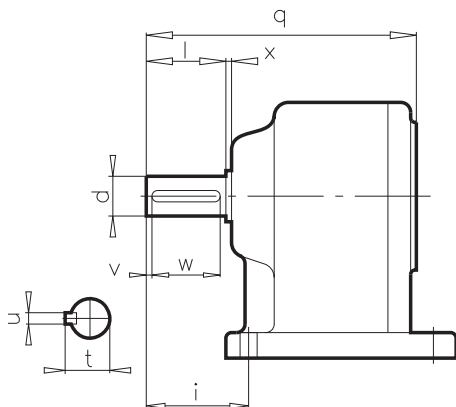
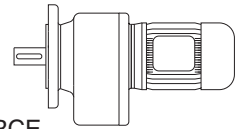

Standardgehäuse der Getriebetypen SK 0 - SK 33 in Fuß- und Flanschführung können mit stärkeren Abtriebswellen, verbunden mit einer Lagerverstärkung, gegen Mehrpreis geliefert werden.

Die Typenbezeichnung wird um die Zahl „5“ erweitert, z.B.: **SK 20 = SK 205**

Standard gearcases of sizes SK 0 - SK 33, foot and flange mounted, can also be supplied with reinforced output shafts in combination with reinforced bearings. Surcharge is to be calculated.

Annex „5“, is the type designation e.g. **SK 20 = SK 205**.

Carters standards des types des réducteurs SK 0 - SK 33 en exécution à pattes et à bride peuvent être livrés aussi avec des arbres des ortie renforcés en combinaison avec des roulements renforcés. Ceci exige un supplément.

La désignation est amplifiée par le numero „5“, p.ex. **SK 20 = SK 205**.

Abtriebswelle verstärkt / Output shaft reinforced / Arbre de sortie renforce

Typ Type Type	Wellenmaße Shaft dimensions Cotes arbre							Befestigungs-, Raum- und Anschlußmaße (Fuß und Flansch) Outline and mounting dimensions (foot and flange) Cotes de fixation, d'encombrement et de montage (pattes et bride)								
	d	l	t	u	v	w	x	a1*	b1	c1	e1	f1	s1	i	i2	q
	SK 05	20	40	22,5	6	5	30	2	-	-	-	-	-	-	52	-
SK 015, SK 0105	25	60	28,0	8	10	40	2	160	110	10	130	3,5	99	88	60	132
SK 205, SK 2005	30	70	33,0	8	10	50	2	160	110	12	130	3,5	9	84	70	172
SK 255, SK 2505	35	70	38,0	10	10	50	2	200	130	12	165	3,5	11	115	70	200
SK 305, SK 3005	40	80	43,0	12	10	60	3	250	180	16	215	4,0	14	96	80	198
SK 335, SK 3305	50	100	53,5	14	10	80	3	300	230	20	265	4,0	14	140	100	223

a1* = weitere Flansch siehe Seite 63.

Alle anderen Maße siehe Seiten 42 - 45.

a1* = Further flanges see page 63.

Other dimensions see pages 42 - 45.

a1* = D'autres voir page 63.

D'autres dimensions voir page 42 - 45.

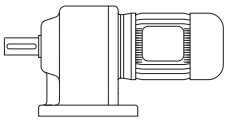

LIEFERBARE AUSFÜHRUNGEN
AVAILABLE DESIGNS
EXECUTIONS LIVRABLES

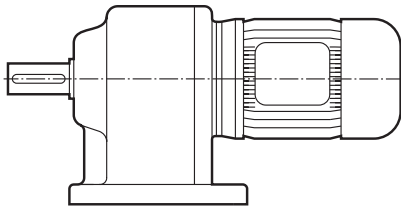
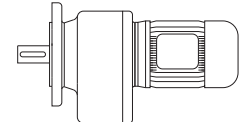

SK 30 - 100 L/4

Stirradtriebemotor, zweistufig, Fußausführung

Helical Geared Motor, double reduction, foot mounted

Motorréducteurs à engrenages cylindriques, à deux trains d'engrenages, exécution à pattes

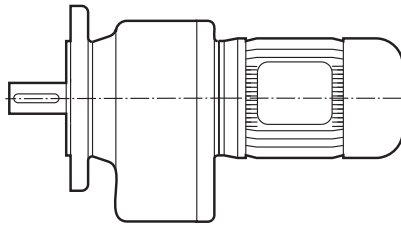

SK 30 F - 100 L/4

Stirradtriebemotor, zweistufig, Flanschausführung

Helical Geared Motor, double reduction, flange mounted

Motorréducteurs à engrenages cylindriques, à deux trains d'engrenages, exécution à bride

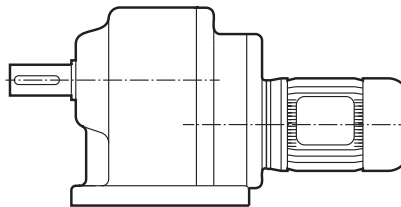

SK 300 - 80 L/4

Stirradtriebemotor, dreistufig, Fußausführung

Helical Geared Motor, triple reduction, foot mounted

Motorréducteurs à engrenages cylindriques, à trois trains d'engrenages, exécution à pattes

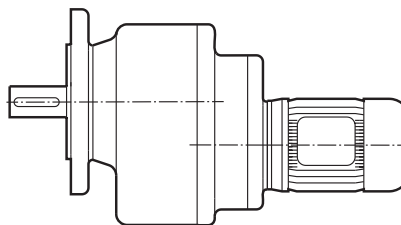

SK 300 F - 80 L/4

Stirradtriebemotor, dreistufig, Flanschausführung

Helical Geared Motor, triple reduction, flange mounted

Motorréducteurs à engrenages cylindriques, à trois trains d'engrenages, exécution à bride

**ANORDNUNG DES KLEMMKASTENS
UND DER KABELINFÜHRUNG**

Lage des Klemmkastens und der Kabeleinführung bitte angeben.

Normalausführung:

Klemmkasten bei 1, Kabeleinführung bei I.
Falls andere Anordnung gewünscht, bitte ausdrücklichen Bestellhinweis.

**POSITION OF TERMINAL BOX
AND CABLE ENTRY**

Please specify position of terminal box and cable entry.

Normal design:

Terminal box at 1, cable entry at I.
If other positions required, please specify exactly when ordering.

**POSITION DE LA BOITE A BORNES
ET DE L'ENTREE DE CABLES**

Veuillez indiquer la position de la boîte à bornes et de l'entrée de câbles.

Exécution normale:

Boîte à bornes en 1, entrée de câbles en I.
Si une autre position est souhaitée, veuillez l'indiquer lors de la commande.

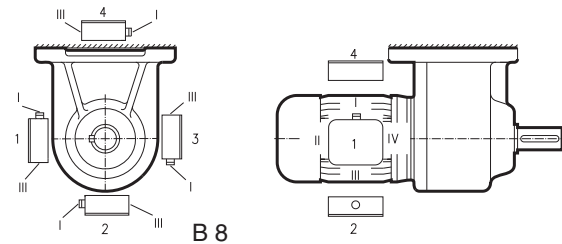

B 8

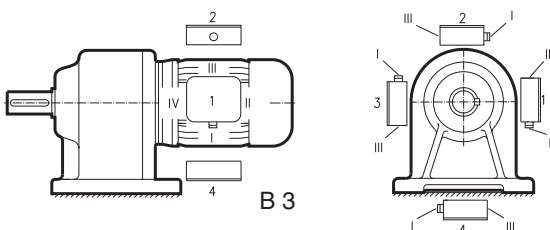

B 3

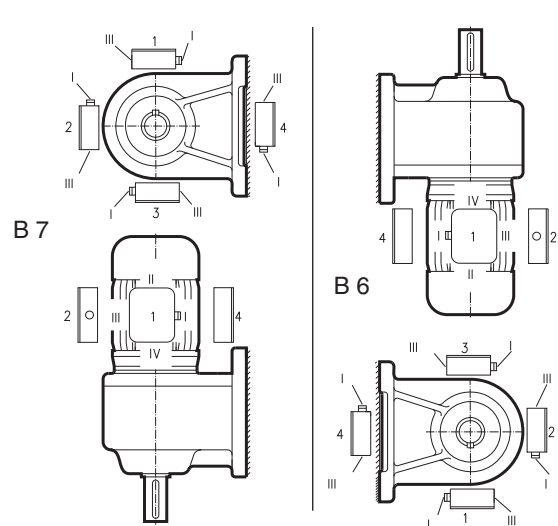

B 7

B 6

TECHNISCHE ERLÄUTERUNGEN / EXPLANATORY NOTES / DESCRIPTIONS TECHNIQUES

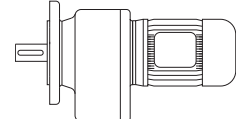
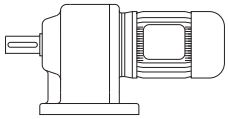

BAUFORMEN MOUNTING POSITIONS POSITIONS DE MONTAGE

	WAAGERECHTE ANORDNUNG	HORIZONTAL POSITION	POSITION HORIZONALE
Bild Figure Figure			
Kurzzeichen Symbol Symbole	M1 (B3)	M1 (B5)	M1 (B3 / B5)
Bild Figure Figure			
Kurzzeichen Symbol Symbole	M3 (B8)	M3 (B5 I)	M3 (B8 / B5 I)
Bild Figure Figure			
Kurzzeichen Symbol Symbole	M5 (B6)	M5 (B5 II)	
Bild Figure Figure			
Kurzzeichen Symbol Symbole	M6 (B7)	M6 (B5 III)	

	SENKRECHTE ANORDNUNG	VERTICAL POSITION	POSITION VERTICALE
Bild Figure Figure			
Kurzzeichen Symbol Symbole	M2 (V6)	M2 (V3)	M2 (V3 / V6)
Bild Figure Figure			
Kurzzeichen Symbol Symbole	M4 (V5)	M4 (V1)	M4 (V1 / V5)

TECHNISCHE ERLÄUTERUNGEN / EXPLANATORY NOTES / DESCRIPTIONS TECHNIQUES

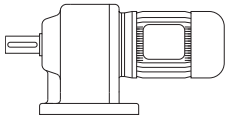

SCHMIERUNG LUBRICATION LUBRIFICATION

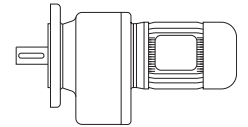

GETRIEBE

Getriebe und Antriebsmotor bilden eine kompakte Einheit, die gegen Umwelteinflüsse (Feuchtigkeit, Schmutz, ...) weitgehend unempfindlich ist. Die Getriebegehäuse bestehen aus Grauguß. Zahnräder sind aus hochverschleißfesten Stählen gefertigt und einsatzgehärtet; Zahnflanken sind geschliffen. Die Schrägverzahnung und die Bearbeitung gewährleisten einen ruhigen Lauf.

Alle Getriebemotoren können mit einem 2. Motorwellenende geliefert werden. Die Abtriebswellen der Getriebe besitzen am Wellenspiegel ein Innengewinde nach DIN 332, Blatt 2.

Liegen außergewöhnliche Betriebsbedingungen vor, erbitten wir Rückfrage unter genauer Angabe der Betriebsverhältnisse.

Die Stirnradgetriebe der Standardreihe können in Fuß- oder Flanschführung geliefert werden. Außerdem ist die Lieferung auch in Fuß / Flanschführung oder in Fußausführung mit angedrehtem Rezeß (B 14) möglich. Die Bauform bitten wir in jedem Fall bekanntzugeben, damit die Entlüftungsschraube entsprechend positioniert werden kann.

GEARBOX

Gearbox and motor form a compact unit which to a great extent is safe against environmental influences (moisture, dirt, ...). The gear housing is made of cast iron. Gears are machined from highly wear-resistant steels and are case-hardened; teeth are ground. Helical gearing and surface finishing of teeth ensure smooth running.

All geared motors can be supplied with a second motor shaft extension. Output shafts of the gearboxes are provided with a tapped centre hole according to DIN 332, sheet 2.

Should unusual conditions of operation exist, please enquire and give us precise information about the operating conditions.

Helical gearboxes of the standard line can be supplied in foot or flange mounted design. Furthermore they are available in foot / flange mounting or foot mounting with flange B 14. Please specify the mounting position when ordering, so that we can place the vent plug in accordingly.

REDUCTEUR

Carter et moteur forment un ensemble compact, étanche dans une très large mesure à l'influence du milieu ambiant, humidité, saleté. Le carter est en fonte grise haute résistance. Les engrenages sont fabriqués en acier trempé et présente une très haute résistance à l'usure. Les flancs de denture sont polis ou subissent un <shafing>. Les engrenages hélicoïdaux et le travail de la finition de la denture garantissent un fonctionnement silencieux du réducteur.

Tous les motoréducteurs peuvent être livrés avec un deuxième bout d'arbre moteur. Les arbres de sortie possèdent un filetage intérieur suivant DIN 332, feuille 2.

En cas de fonctionnement particulier veuillez nous contacter en nous donnant des indications précises.

Les réducteurs à engrenages cylindriques de la gamme standard peuvent être livrés avec bride ou pattes. La livraison des modèles à pattes et bride B5 ou pattes et bride B14 est également possible. Veuillez nous indiquer la position de montage pour un positionnement correct du bouchon d'évent.

Öfüllmenge: ca. cm³ / Oil Capacity: app. cm³ / Quantité de lubrifiant: cm³

Typ Type Type	Bauformen / Mounting positions / Positions de montage						Typ Type Type	Bauformen / Mounting positions / Positions de montage					
	M1 B3	M2 V6	M3 B8	M4 V5	M5 B6	M6 B7		M1 B5	M2 V3	M3 B5I	M4 V1	M5 B5II	M6 B5III
SK 0	130	220	130	220	130	130	SK 0F	130	220	130	220	130	130
SK 01	220	380	220	380	220	220	SK 01F	220	380	220	380	220	220
SK 20	550	1000	550	1000	550	550	SK 20F	350	600	350	600	350	350
SK 25	500	1000	500	1000	500	500	SK 25F	500	1000	500	1000	500	500
SK 30	700	1400	700	1400	700	700	SK 30F	700	1400	700	1400	700	700
SK 33	800	1600	800	1600	800	800	SK 33F	800	1600	800	1600	800	800
SK 010	380	600	380	600	380	380	SK 010F	380	600	380	600	380	380
SK 200	800	1300	800	1300	800	800	SK 200F	600	1040	600	1040	600	600
SK 250	1400	1500	1400	1500	1400	1400	SK 250F	1400	1500	1400	1500	1400	1400
SK 300	1400	1500	1400	1500	1400	1400	SK 300F	1400	1500	1400	1500	1400	1400
SK 330	1500	1580	1500	1580	1500	1500	SK 330F	1500	1580	1500	1580	1500	1500

Anordnung der Entlüftungsschrauben

zweistufig
double reduction
à deux trains d'engrenages

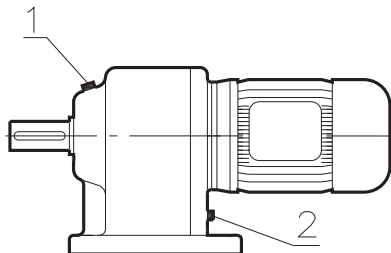

Position of vent plugs

dreistufig
triple reduction
à trois trains d'engrenages

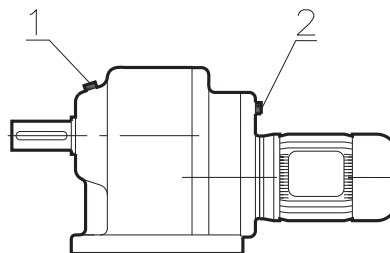

Disposition des vis d'évent

Ansicht auf die Abtriebswelle
View on output shaft
Vue côté arbre de sortie

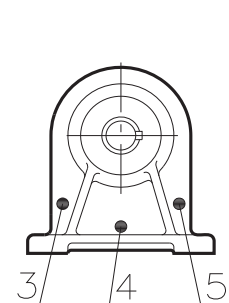

Schmierung Lubrication Lubrification	Bauform Mounting position Position de montage	Entlüftungsschraube bei Pos. Vent plug position Position vis d'évent
Öfüllung Oil Remplissage huile	M1 (B3, B5, B3/B5)	1
	M3 (B8, B5I, B8/B5I)	4
	M5 (B6, B5II)	3 ¹⁾
	M6 (B7, B5III)	5 ¹⁾
	M2 (V3, V6, V3/V6)	4
	M4 (V1, V5, V1/V5)	2

¹⁾ Den Bauformen B6 und B7 werden fünf Verschlußschrauben zugeordnet (1, 2, 3, 4 und 5).

¹⁾ Five sealing plugs (1, 2, 3, 4 and 5) are fitted to mountings B6 and B7.

¹⁾ Pour les positions B6 et B7 il y a 5 bouchons filetés (1, 2, 3, 4, et 5).

Hinweis:

Diese Tabelle stellt vergleichbare Schmierstoffe unterschiedlicher Hersteller dar. Innerhalb einer Viskosität und Schmierstoffsorte kann der Ölhersteller gewechselt werden. Beim Wechsel der Viskosität bzw. der Schmierstoffsorte muß Rücksprache mit uns gehalten werden, da sonst keine Gewährleistung für die Funktionstüchtigkeit unserer Getriebe übernommen werden kann.

Note:

This table lists compatible lubricants of different suppliers. Within the same viscosity class and type of lubricant the supplier can be chosen freely. In case you change the viscosity class resp. the type of lubricant you should contact us in advance as otherwise we cannot assure the proper function of our drive and the warranty becomes void.

Indication:

Ce tableau présente les lubrifiants comparables des différents fabricants. Si l'on respecte les critères de viscosité et le type de lubrifiant, on peut utiliser n'importe quelle marque d'huile après le vidange. Afin de pouvoir garantir un bon fonctionnement de nos réducteurs, veuillez nous consulter avant de remplacer un lubrifiant par un autre possédant des caractéristiques différentes de viscosité et de type.

Schmierstoffart Type of lubricant Type de lubrifiant	Umgebungstemp. Ambient temp. Temp. ambiante	ARAL	BP	Castrol	DEA	ESSO	FUCHS	KLÜBER LUBRICATION	Mobil	Optimal	Shell	Tribol
Mineralöl Mineral oil Huile minérale	ISO VG 220 - 5... 40°C (normal)	Degol BG 220 BG 220 plus	Energol GR-XP 220	Alpha SP 220 Alpha MW 220 Alpha MAX 220	Falcon CLP 220	Spartan EP 220	Renolin CLP 220 Renolin CLP 220 Plus	Klüberoil GEM 1-220	Mobilgear 630	Optigear BM 220	Shell Omala Oel 220	Tribol 1100 / 220
	ISO VG 100 - 15... 25°C	Degol BG 100 BG 100 plus	Energol GR-XP 100	Alpha SP 100 Alpha MW 100 Alpha MAX 220	Falcon CLP 150	Spartan EP 100	Renolin CLP 100 Renolin CLP 100 Plus	Klüberoil GEM 1-100	Mobilgear 627	Optigear BM 100	Shell Omala Oel 100	Tribol 1100 / 100
	ISO VG 15 *- 45... -15	Vitaloil 1010	Bartran HV15	Hyspin AWS 15 Hyspin SP 15 Hyspin ZZ 15	Astron HVLP 15	Univis J 13	Renolin B 15 HVI	Isolflex MT 30 rot	Mobil DTE 11 M	Ultra 10	Shell Tellus Oel T 15	Tribol 943 AW 22
Synthetisches Öl Synthetic Oil Huile synthétique	ISO VG 220 *- 25... 80°C	Degol GS 220	Energyn SG-XP 220	Alphasyn PG 220	Polydea PGLP 220	Glycolube 220	Renolin PG 220	Kiubersynth GH 6-220	Glygoyle HE 220	Optiflex A 680	Shell Tivela WB Tivela S 220	Tribol 800 / 220
Biologisch abbaubare Öle Biodegradable oil Huiles biodégradables	ISO VG 220 - 5... 40°C	Degol BAB 220	Biogear SE 220	Carelube GES 220	Ergon ELP 220		Plantogear CLP 220	Kiüber-Bio GM2 - 220	Optisyn BS 220			Tribol Bio Top 1418 / 220
Lebensmittelverträgliches Öl ¹⁾ Food-grade oil ¹⁾ Huiles pour environne- ment alimentaire ¹⁾	ISO VG 220 - 25... 40°C	Eural Gear 220		Vitalube GS 220		Gear Oil FM 220	Bel-Ray No-Tox Gear Oil 90 Synt. Gear Oil 220	Kiüberoil 4UH1-220	Mobil DTE FM 220	Optileb GT 220	Shell Cassida Fluid GL 220	Tribol Food Proof 1810 / 220 oder/or/ou 1800 / 220
Synthetisches Fliessfett Synthetic fluid grease Graisse fluide synthétique	- 25... 60°C	Aralub BAB EPO	Energyn GSF	Alpha Gel 00		Fliessfett S 420	Renolit LX-PG 00	Kiubersynth GE 46-1200 UH1 14-1600	Glygoyle Grease 00	Obeen UF 00	Tivela compound A Tivela GL 00	Tribol 800 / 1000
Fett (Mineralölbasis) Grease (mineral oil base) Graisse (base huile min.)	- 30... 60°C (normal) *- 50... 40°C	Aralub HL 2 Aralub SEL 2	Energrease LS 2	Spheerol AP 2 LZV - EP	Glissando 20	Beacon 2	Renolit FWA160	Kiüberplex BEM 41-132	Mobilux 2	Logitime PD 2	Shell Alvania R2	Tribol 4020/220-2 Tribol 3785
Synthetisches Fett Synthetic grease Graisse synthétique	*- 25... 80°C	Aralub SKL 2		Product 783 / 46	Discor B-EP 2LF	Beacon 325	Renolit S2 Renolit HLT 2	Isolflex Topas NCA 52 Isolflex Topas NB 52	Mobiltemp SHC 32	Optitemp LG 2	Aero Shell Grease 16 oder 7	Tribol 3499
Biologisch abbaubares Fett Biodegradable Grease Graisse biodégradables	- 25... 40°C	Aralub BAB EP 2	BP Biogrease EP 2	Biotec	Dolon E EP 2	Carum 330	Renolit S 2	Kiüberbio M 32 - 82	Schmierfett UE 100 B	EF 584	Shell Alvania RLB 2	Molub-Alloy BioTop 9488
Lebensmittelverträgliches Fett ¹⁾ Food-grade grease ¹⁾ Graisse pour environne- ment alimentaire ¹⁾	- 25... 40°C	Eural Grease EP 2	BP Energrease FM 2	Vitalube HT Grease 2	Tamir FRA 1		Renolit G7 FG1	Kiubersynth UH1 14-151	Mobilgrease FM 102	Obeen UF 2	Shell Cassida RLS 2	Molub-Alloy Food-Proof 823-2 FM

* Bei Umgebungstemperaturen unterhalb -30°C und oberhalb 60°C sind Wellendichtringe in besonderer Werkstoffqualität einzusetzen

* With ambient temperatures below -30°C and above approx. 60°C shaft seals of a special material quality must be used

* Lors d'une température ambiante inférieure à -30°C ou supérieure à environ 60°C, il y a lieu d'utiliser des joints d'étanchéité spéciaux

¹⁾ Lebensmittelverträgliche Öle + Fette nach Vorschrift H1 / FDA 178.3570

¹⁾ Food grade lubricants with USDA-H1 approval FDA 178.3570

¹⁾ Huiles pour environnement alimentaire + graisses suivant prescription H1 / FDA 178.3570

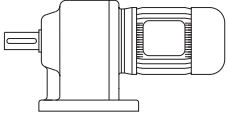

TECHNISCHE ERLÄUTERUNGEN EXPLANATORY NOTES DESCRIPTIONS TECHNIQUES

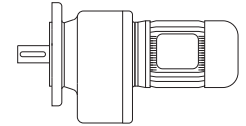

INFORMATIONEN ZU DEN MASSBILDERN GETRIEBEMOTOREN UND GETRIEBE

Maßangaben zu den Motoren können sich unter Umständen teilweise verändern.

Maßänderungen durch Bremsmotorenanbau siehe Seite : 69

INFORMATION REFERRING TO DIMENSION - DRAWINGS GEARED MOTORS AND GEARBOXES

Dimensions of motors are subject to change.

For additional dimensions with brake-motors see page : 69

INFORMATIONS RELATIVES AUX DESSINS COTES DES MOTOREDUCTEURS ET REDUCTEURS

Les cotes des moteurs peuvent le cas echeant etre partiellement modifiées.

Pour les moteus frein voir modifications de cotes page : 69

ABTRIEBS - UND ANTRIEBSWELLENENDEN

Toleranz der Wellen- ϕ (DIN 748) :
= ϕ 14 - ϕ 50 mm nach ISO k6,

Zentrierbohrungen mit Gewinde nach
DIN 332, Blatt 2 :

=	ϕ 13 - ϕ 16	= M5
>	ϕ 16 - ϕ 21	= M6
>	ϕ 21 - ϕ 24	= M8
>	ϕ 24 - ϕ 30	= M10
>	ϕ 30 - ϕ 38	= M12
>	ϕ 38 - ϕ 50	= M16

Paßfedern nach DIN 6885, Blatt1.

Achshöhe „h“ nach DIN 747

OUTPUT AND INPUT SHAFT ENDS

Diametre tolerance (DIN 748) :
= ϕ 14 - ϕ 50 mm to ISO k6,

Tapped center hole to
DIN 332, sheet 2 :

=	ϕ 13 - ϕ 16	= M5
>	ϕ 16 - ϕ 21	= M6
>	ϕ 21 - ϕ 24	= M8
>	ϕ 24 - ϕ 30	= M10
>	ϕ 30 - ϕ 38	= M12
>	ϕ 38 - ϕ 50	= M16

Keyways to DIN 6885, sheet 1.

Shaft heights „h“ to DIN 747

BOUTS D' ARBRE DE SORTIE ET ARBRE D'ENTREE

Tolérances au niveau diamètre (DIN 748) :
= ϕ 14 - ϕ 50 mm ISO k6,

Trous de centrage taraudés suivant
DIN 332, feuille 2.

=	ϕ 13 - ϕ 16	= M5
>	ϕ 16 - ϕ 21	= M6
>	ϕ 21 - ϕ 24	= M8
>	ϕ 24 - ϕ 30	= M10
>	ϕ 30 - ϕ 38	= M12
>	ϕ 38 - ϕ 50	= M16

Clavetage suivant DIN 6885, feuille 1.

Hauteur d'axe „h“ suivant DIN 747

FLANSCHEN

Toleranz der Flanschzentrier- ϕ (DIN 42 948) :

<=	ϕ 230 mm nach ISO j6,
>	ϕ 230 mm nach ISO h6.

IEC - ADAPTER

Toleranz der Flanschzentrierung
nach ISO H7

Diese Tabelle gilt auch für Stirnradgetriebe - Type W und Type IEC.

FLANGES

Diametre tolerance of flange centering (DIN 42948) :

<=	ϕ 230 mm to ISO j6,
>	ϕ 230 mm to ISO h6.

IEC - ADAPTOR

Diametre tolerance of flange centering
to ISO H7.

This table is also valid for Helical Gear Units Type W and Type IEC.

BRIDES

Tolérances au niveau diamètre de centrage de la bride (DIN 42 948) :

<=	ϕ 230 mm ISO j6,
>	ϕ 230 mm ISO h6.

IEC - LANTERNE

Tolérances au niveau diamètre de centrage de la bride ISO H7.

Les tableaux sont valables pour réducteurs à engrenages cylindriques type W et type IEC.



STIRNRADGETRIEBEMOTOREN HELICAL GEARED MOTORS MOTOREDUCTEURS A ENGRENAGES CYLINDRIQUES

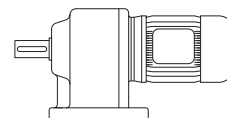

DREHSTROM
THREE PHASE
A COURANT TRIPHASE

P _n [kW]	n ₂ [min ⁻¹]	M _a [Nm]	Standard f _B	i _{ges}	Normallagerung Normal bearing Roulement normal		Typenzusatz 5 Affix 5 Suffixe 5		Typ Type Type	ca. kg	Maße Dimens. Cotes			
					F _{Q N} ¹⁾ [N]	F _{A N} ²⁾ [N]	F _Q ¹⁾ [N]	F _A ²⁾ [N]						
0.12	2.8	409	1.0	484.62	6860	7650	11110	9000	SK 300 - 63S/4	32	44 - 45			
	3.2	358	1.1	429.23	7050	7650	11220	9000						
	3.6	318	1.3	383.92	7180	7650	11290	9000						
	4.0	286	1.2	376.15	7270	7650	11340	9000						
	4.4	260	1.5	314.20	7340	7650	11370	9000						
	4.8	239	1.7	286.81	7390	7650	11400	9000						
	5.2	220	1.8	263.08	7430	7650	11420	9000						
		3.2	358	0.8	425.34	4020	5600	7050	7650	SK 250 - 63S/4	21	44 - 45		
		3.6	318	0.9	374.85	4240	5600	7180	7650					
		3.8	302	0.8	357.73	4320	5600	7230	7650					
		4.0	286	1.0	333.54	4400	5600	7270	7650					
		4.4	260	1.2	311.75	4510	5600	7340	7650					
	4.9	234	1.3	274.74	4610	5600	7400	7650						
	5.6	205	1.5	244.47	4700	5600	7460	7650						
	6.3	182	1.6	219.79	4760	5600	7500	7650						
	7.0	164	1.8	198.49	4810	5600	7530	7650						
	7.7	149	2.0	179.98	4840	5600	7550	7650						
	8.4	136	2.2	164.29	4870	5600	7570	7650						
	9.2	125	2.3	150.83	4890	5600	7580	7650						
	9.9	116	2.2	138.49	4900	5600	7590	7650						
	11	102	3.1	122.88	4930	5600	7600	7650						
	4.5	255	0.8	304.80	2740	3900	5320	5600	SK 200 - 63S/4	23	44 - 45			
	5.1	225	0.9	268.49	2970	3900	5420	5600						
	5.8	198	1.0	238.77	3150	3900	5500	5600						
	6.4	179	1.1	214.01	3250	3900	5550	5600						
	7.1	161	1.2	193.06	3340	3900	5590	5600						
	7.9	145	1.4	175.10	3410	3900	5620	5600						
	8.6	133	1.4	159.54	3450	3900	5640	5600						
	9.5	121	1.4	145.92	3500	3900	5660	5600						
	10	111	1.4	133.90	3530	3900	5680	5600						
	11	102	1.4	123.22	3550	3900	5690	5600						
	12	96	2.1	76.50	3570	3900	5700	5600				SK 20 - 63L/6	16	42 - 43
	14	82	2.4	66.56	3600	3900	5720	5600						
	15	76	2.6	61.80	3610	3900	5720	5600						
	16	72	2.7	58.65	3620	3900	5730	5600						
	17	67	3.0	53.77	3630	3900	5730	5600						
	18	64	3.1	76.50	3630	3900	5730	5600	SK 20 - 63S/4	16	42 - 43			
	21	55	3.7	66.56	3650	3900	5740	5600						
	22	52	3.8	61.80	3650	3900	5740	5600						
	24	48	> 4.0	58.65	3660	3900	5750	5600						
	26	44	> 4.0	53.77	3660	3900	5750	5600						
	9.4	122	0.8	145.23	1830	2500	3490	3900	SK 010 - 63S/4	16	44 - 45			
	10	110	0.9	132.60	1950	2500	3530	3900						
	11	101	1.0	121.55	2030	2500	3550	3900						
	12	96	1.0	111.61	2070	2500	3570	3900	SK 01 - 63S/4	13	42 - 43			
	14	82	1.2	97.35	2160	2500	3600	3900						
	16	72	1.2	85.85	2220	2500	3620	3900						
	18	64	1.5	76.12	2260	2500	3630	3900						
	21	55	1.8	66.40	2300	2500	3650	3900						
	24	48	1.9	58.50	2320	2500	3660	3900						
	27	42	2.4	51.03	2340	2500	3660	3900						
	31	37	2.7	45.00	2350	2500	3670	3900						
	34	34	3.0	40.05	2360	2500	3670	3900						
	38	30	3.3	36.00	2370	2500	3680	3900						
	42	27	3.4	32.58	2370	2500	3680	3900						
	47	24	3.4	29.61	2380	2500	3680	3900						
	51	22	3.4	27.00	2380	2500	3680	3900						
	56	20	3.4	24.75	2390	2500	3610	3900						
	61	19	3.5	22.77	2390	2500	3510	3900						
	66	17	3.5	20.97	2390	2500	3430	3900						
	71	16	3.4	19.44	2390	2500	3350	3900						
	77	15	3.4	18.00	2390	2500	3260	3900						
	82	14	3.4	16.74	2390	2500	3200	3900						

1) bei / at / pour F_A = 0 N

2) bei / at / pour F_Q = 0 N

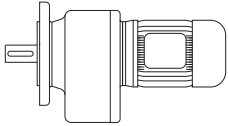

STIRNRADGETRIEBMOTOREN HELICAL GEARED MOTORS MOTOREDUCTEURS A ENGRENAGES CYLINDRIQUES



DREHSTROM
THREE PHASE
A COURANT TRIPHASE

P _n [kW]	n ₂ [min ⁻¹]	M _a [Nm]	Standard f _B	i _{ges}	Normallagerung Normal bearing Roulement normal		Typenzusatz 5 Affix 5 Suffixe 5		Typ Type Type	ca. kg	Maße Dimens. Cotes				
					F _{Q N} ¹⁾ [N]	F _{A N} ²⁾ [N]	F _Q ¹⁾ [N]	F _A ²⁾ [N]							
0.12	83	14	> 4.0	16.90	2390	2500	3200	3900	SK 01 - 63S/4	13	42 - 43				
	89	13	3.4	15.57	2390	2500	3110	3900							
	95	12	> 4.0	14.74	2390	2500	3060	3900							
	107	11	> 4.0	13.00	2360	2500	2950	3900							
	120	10	> 4.0	11.57	2280	2500	2840	3900							
	134	9	> 4.0	10.40	2200	2500	2740	3900							
	150	8	> 4.0	9.41	2120	2500	2640	3900							
	165	7	> 4.0	8.55	2060	2500	2560	3900							
	181	6	> 4.0	7.80	2000	2500	2480	3900							
	197	6	> 4.0	7.15	1940	2500	2420	3900							
	214	5	> 4.0	6.58	1890	2500	2350	3900							
	233	5	> 4.0	6.06	1840	2500	2290	3900							
	251	5	> 4.0	5.62	1790	2500	2230	3900							
	271	4	> 4.0	5.20	1750	2500	2180	3900							
	291	4	> 4.0	4.84	1710	2500	2130	3900							
	313	4	> 4.0	4.50	1670	2500	2070	3900							
	327	4	> 4.0	4.31	1650	2500	2050	3900							
	359	3	> 4.0	3.93	1600	2500	1980	3900							
	392	3	> 4.0	3.60	1550	2500	1930	3900							
	426	3	> 4.0	3.31	1510	2500	1870	3900							
	462	3	> 4.0	3.05	1470	2500	1830	3900							
	498	2	> 4.0	2.83	1430	2500	1780	3900							
	538	2	> 4.0	2.62	1400	2500	1740	3900							
	578	2	> 4.0	2.44	1370	2500	1700	3900							
	624	2	> 4.0	2.26	1330	2500	1650	3900							
		19	60	0.8	70.98	980	1620	2600				2500	SK 0 - 63S/4	10	42 - 43
		22	52	1.0	61.96	1050	1620	2630				2500			
		25	46	1.1	54.46	1100	1620	2650				2500			
		28	41	1.2	47.54	1140	1620	2660				2500			
		32	36	1.4	42.01	1160	1620	2680				2500			
		40	29	1.7	33.69	1200	1620	2690				2500			
		46	25	2.0	30.50	1210	1620	2700				2500			
	50	23	2.2	27.77	1220	1620	2700	2500							
	60	19	2.6	23.34	1230	1620	2710	2500							
	69	17	2.7	19.92	1240	1620	2710	2500							
	81	14	2.7	17.12	1240	1620	2710	2500							
	91	13	> 4.0	15.12	1250	1620	2710	2500							
	105	11	> 4.0	13.20	1250	1620	2720	2500							
	118	10	> 4.0	11.66	1250	1620	2720	2500							
	148	8	> 4.0	9.35	1250	1620	2530	2500							
	163	7	> 4.0	8.47	1240	1620	2460	2500							
	179	6	> 4.0	7.71	1210	1620	2380	2500							
	213	5	> 4.0	6.48	1150	1620	2250	2500							
	250	5	> 4.0	5.53	1090	1620	2130	2500							
	291	4	> 4.0	4.75	1040	1620	2030	2500							
	309	4	> 4.0	4.46	1020	1620	1990	2500							
	342	3	> 4.0	4.04	980	1620	1930	2500							
	375	3	> 4.0	3.68	950	1620	1870	2500							
	447	3	> 4.0	3.09	900	1620	1770	2500							
	523	2	> 4.0	2.64	860	1620	1670	2500							
	608	2	> 4.0	2.27	820	1620	1590	2500							
0.18	3.6	478	0.8	383.92	6540	7650	10950	9000	SK 300 - 63L/4	32	44 - 45				
	4.0	430	0.8	376.15	6770	7650	11070	9000							
	4.4	391	1.0	314.20	6930	7650	11150	9000							
	4.8	358	1.1	286.81	7050	7650	11220	9000							
	5.2	331	1.2	263.08	7140	7650	11260	9000							
	5.7	302	1.3	242.31	7230	7650	11310	9000							
	6.2	277	1.4	223.98	7300	7650	11350	9000							
	6.6	260	1.5	207.69	7340	7650	11370	9000							
	7.1	242	1.5	193.12	7380	7650	11400	9000							
	7.7	223	1.5	180.00	7420	7650	11420	9000							
	8.1	212	1.9	169.39	7440	7650	11430	9000							
		4.4	391	0.8	311.75	3800	5600	6930				7650	SK 250 - 63L/4	21	44 - 45
	4.9	351	0.9	274.74	4060	5600	7070	7650							
	5.6	307	1.0	244.47	4300	5600	7210	7650							

1) bei / at / pour F_A = 0 N

2) bei / at / pour F_Q = 0 N



STIRNRADGETRIEBEMOTOREN HELICAL GEARED MOTORS MOTOREDUCTEURS A ENGRENAGES CYLINDRIQUES

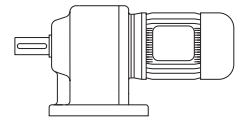

DREHSTROM
THREE PHASE
A COURANT TRIPHASE

P _n [kW]	n ₂ [min ⁻¹]	M _a [Nm]	Standard f _B	i _{ges}	Normallagerung Normal bearing Roulement normal		Typenzusatz 5 Affix 5 Suffixe 5		Typ Type Type	ca. kg	Maße Dimens. Cotes				
					F _{Q N} ¹⁾ [N]	F _{A N} ²⁾ [N]	F _Q ¹⁾ [N]	F _A ²⁾ [N]							
0.18	6.3	273	1.1	219.79	4450	5600	7310	7650	SK 250 - 63L/4	21	44 - 45				
	7.0	246	1.2	198.49	4560	5600	7370	7650							
	7.7	223	1.3	179.98	4640	5600	7420	7650							
	8.4	205	1.5	164.29	4700	5600	7460	7650							
	9.2	187	1.5	150.83	4750	5600	7490	7650							
	9.9	174	1.5	138.49	4780	5600	7510	7650							
	11	153	2.0	122.88	4830	5600	7540	7650							
	13	135	2.2	108.29	4870	5600	7570	7650							
	14	120	2.5	96.36	4900	5600	7580	7650							
	15	112	2.7	90.06	4910	5600	7590	7650							
		7.1	242	0.8	193.06	2850	3900	5370				5600	SK 200 - 63L/4	23	44 - 45
		7.9	218	0.9	175.10	3020	3900	5440				5600			
		8.6	200	0.9	159.54	3140	3900	5490				5600			
		9.5	181	0.9	145.92	3240	3900	5540				5600			
		10	167	0.9	133.90	3310	3900	5580				5600			
	11	153	0.9	123.22	3380	3900	5610	5600							
	12	143	1.4	76.50	3420	3900	5630	5600	SK 20 - 71S/6	17	42 - 43				
	14	123	1.6	66.56	3490	3900	5660	5600							
	15	115	1.7	61.80	3510	3900	5670	5600							
	16	107	1.8	58.65	3540	3900	5690	5600							
	17	101	2.0	53.77	3550	3900	5690	5600							
	18	96	2.1	76.50	3570	3900	5700	5600	SK 20 - 63L/4	16	42 - 43				
	21	82	2.4	66.56	3600	3900	5720	5600							
	22	78	2.6	61.80	3610	3900	5720	5600							
	24	72	2.7	58.65	3620	3900	5730	5600							
	26	66	3.0	53.77	3630	3900	5730	5600							
	29	59	3.4	47.38	3640	3900	5740	5600							
	33	52	3.8	42.13	3650	3900	5740	5600							
	14	123	0.8	97.35	1820	2500	3490	3900	SK 01 - 63L/4	13	42 - 43				
	16	107	0.8	85.85	1980	2500	3540	3900							
	18	96	1.0	76.12	2070	2500	3570	3900							
	21	82	1.2	66.40	2160	2500	3600	3900							
	24	72	1.3	58.50	2220	2500	3620	3900							
	27	64	1.6	51.03	2260	2500	3630	3900							
	31	55	1.8	45.00	2300	2500	3650	3900							
	34	51	2.0	40.05	2310	2500	3650	3900							
	38	45	2.2	36.00	2330	2500	3660	3900							
	42	41	2.3	32.58	2340	2500	3670	3900							
	47	37	2.3	29.61	2350	2500	3670	3900							
	51	34	2.3	27.00	2360	2500	3650	3900							
	56	31	2.3	24.75	2370	2500	3550	3900							
	61	28	2.3	22.77	2370	2500	3460	3900							
	66	26	2.3	20.97	2380	2500	3380	3900							
	71	24	2.3	19.44	2380	2500	3300	3900							
	77	22	2.3	18.00	2380	2500	3230	3900							
	82	21	2.3	16.74	2380	2500	3160	3900							
	83	21	> 4.0	16.90	2380	2500	3160	3900							
	89	19	2.3	15.57	2390	2500	3080	3900							
	95	18	> 4.0	14.74	2390	2500	3030	3900							
	107	16	> 4.0	13.00	2330	2500	2920	3900							
	120	14	> 4.0	11.57	2250	2500	2810	3900							
	134	13	> 4.0	10.40	2170	2500	2720	3900							
	150	11	> 4.0	9.41	2100	2500	2620	3900							
	165	10	> 4.0	8.55	2040	2500	2540	3900							
	181	10	> 4.0	7.80	1980	2500	2460	3900							
	197	9	> 4.0	7.15	1920	2500	2400	3900							
	214	8	> 4.0	6.58	1880	2500	2340	3900							
	233	7	> 4.0	6.06	1820	2500	2270	3900							
	251	7	> 4.0	5.62	1780	2500	2220	3900							
	271	6	> 4.0	5.20	1740	2500	2160	3900							
	291	6	> 4.0	4.84	1700	2500	2110	3900							
	313	6	> 4.0	4.50	1660	2500	2060	3900							
	327	5	> 4.0	4.31	1640	2500	2040	3900							
	359	5	> 4.0	3.93	1590	2500	1980	3900							
	392	4	> 4.0	3.60	1540	2500	1920	3900							

1) bei / at / pour F_A = 0 N

2) bei / at / pour F_Q = 0 N

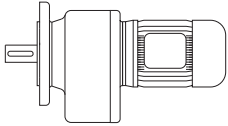

STIRNRADGETRIEBMOTOREN HELICAL GEARED MOTORS MOTOREDUCTEURS A ENGRENAGES CYLINDRIQUES



DREHSTROM
THREE PHASE
A COURANT TRIPHASE

P _n [kW]	n ₂ [min ⁻¹]	M _a [Nm]	Standard f _B	i _{ges}	Normallagerung Normal bearing Roulement normal		Typenzusatz 5 Affix 5 Suffixe 5		Typ Type Type	ca. kg	Maße Dimens. Cotes			
					F _{Q N} ¹⁾ [N]	F _{A N} ²⁾ [N]	F _Q ¹⁾ [N]	F _A ²⁾ [N]						
0.18	426	4	> 4.0	3.31	1500	2500	1870	3900	SK 01 - 63L/4	13	42 - 43			
	462	4	> 4.0	3.05	1460	2500	1820	3900						
	498	4	> 4.0	2.83	1430	2500	1780	3900						
	538	3	> 4.0	2.62	1390	2500	1730	3900						
	578	3	> 4.0	2.44	1360	2500	1690	3900						
	624	3	> 4.0	2.26	1330	2500	1650	3900						
	28	61	0.8	47.54	960	1620	2590	2500				SK 0 - 63L/4	10	42 - 43
	32	54	0.9	42.01	1040	1620	2620	2500						
	40	43	1.2	33.69	1120	1620	2660	2500						
	46	37	1.3	30.50	1160	1620	2670	2500						
	50	34	1.5	27.77	1170	1620	2680	2500						
	60	29	1.7	23.34	1200	1620	2690	2500						
	69	25	1.8	19.92	1210	1620	2700	2500						
	81	21	1.8	17.12	1230	1620	2710	2500						
	91	19	2.6	15.12	1230	1620	2710	2500						
	105	16	3.1	13.20	1240	1620	2710	2500						
	118	15	3.4	11.66	1240	1620	2690	2500						
	148	12	> 4.0	9.35	1250	1620	2510	2500						
	163	11	> 4.0	8.47	1220	1620	2430	2500						
	179	10	> 4.0	7.71	1190	1620	2360	2500						
	213	8	> 4.0	6.48	1130	1620	2230	2500						
	250	7	> 4.0	5.53	1070	1620	2120	2500						
	291	6	> 4.0	4.75	1030	1620	2020	2500						
	309	6	> 4.0	4.46	1010	1620	1980	2500						
	342	5	> 4.0	4.04	970	1620	1920	2500						
	375	5	> 4.0	3.68	950	1620	1860	2500						
	447	4	> 4.0	3.09	890	1620	1760	2500						
	523	3	> 4.0	2.64	850	1620	1670	2500						
608	3	> 4.0	2.27	810	1620	1590	2500							
0.25	4.8	497	0.8	286.81	6440	7650	10900	9000	SK 300 - 71S/4	33	44 - 45			
	5.2	459	0.9	263.08	6630	7650	11000	9000						
	5.7	419	1.0	242.31	6810	7650	11090	9000						
	6.2	385	1.0	223.98	6950	7650	11160	9000						
	6.6	362	1.1	207.69	7030	7650	11210	9000						
	7.1	336	1.1	193.12	7120	7650	11260	9000						
	7.7	310	1.1	180.00	7200	7650	11300	9000						
	8.1	295	1.4	169.39	7250	7650	11320	9000						
	9.1	262	1.5	151.51	7330	7650	11370	9000						
	10	236	1.4	136.61	7390	7650	11400	9000						
	5.6	426	0.7	244.47	3530	5600	6780	7650	SK 250 - 71S/4	22	44 - 45			
	6.3	379	0.8	219.79	3880	5600	6970	7650						
	7.0	341	0.9	198.49	4120	5600	7110	7650						
	7.7	310	1.0	179.98	4290	5600	7200	7650						
	8.4	284	1.1	164.29	4410	5600	7280	7650						
	9.2	260	1.1	150.83	4510	5600	7340	7650						
	9.9	241	1.1	138.49	4580	5600	7380	7650						
	11	213	1.5	122.88	4670	5600	7440	7650						
	13	188	1.6	108.29	4750	5600	7490	7650						
	14	167	1.8	96.36	4800	5600	7520	7650						
	15	156	1.9	90.06	4830	5600	7540	7650						
	17	137	2.2	79.37	4870	5600	7560	7650						
	20	121	2.5	70.62	4900	5600	7580	7650						
	22	109	2.8	63.50	4910	5600	7600	7650						
	24	98	3.1	57.34	4930	5600	7610	7650						
	12	199	1.0	76.50	3140	3900	5500	5600	SK 20 - 71L/6	18	42 - 43			
	14	171	1.2	66.56	3290	3900	5570	5600						
	15	159	1.3	61.80	3350	3900	5590	5600						
16	149	1.3	58.65	3390	3900	5610	5600							
17	140	1.4	53.77	3430	3900	5630	5600							
18	133	1.5	76.50	3450	3900	5640	5600	SK 20 - 71S/4	17	42 - 43				
21	114	1.8	66.56	3520	3900	5680	5600							
22	109	1.8	61.80	3530	3900	5680	5600							
24	99	2.0	58.65	3560	3900	5700	5600							

1) bei / at / pour F_A = 0 N

2) bei / at / pour F_Q = 0 N



STIRNRADGETRIEBEMOTOREN HELICAL GEARED MOTORS MOTOREDUCTEURS A ENGRENAGES CYLINDRIQUES

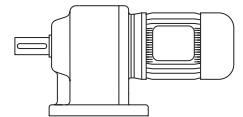

DREHSTROM
THREE PHASE
A COURANT TRIPHASE

P _n [kW]	n ₂ [min ⁻¹]	M _a [Nm]	Standard f _B	i _{ges}	Normallagerung Normal bearing Roulement normal		Typenzusatz 5 Affix 5 Suffixe 5		Typ Type Type	ca. kg	Maße Dimens. Cotes			
					F _{Q N} ¹⁾ [N]	F _{A N} ²⁾ [N]	F _Q ¹⁾ [N]	F _A ²⁾ [N]						
0.25	26	92	2.2	53.77	3580	3900	5710	5600	SK 20 - 71S/4	17	42 - 43			
	29	82	2.4	47.38	3600	3900	5720	5600						
	33	72	2.8	42.13	3620	3900	5730	5600						
	37	65	3.1	37.80	3630	3900	5730	5600						
	40	60	3.3	34.09	3640	3900	5740	5600						
	45	53	3.4	30.90	3650	3900	5710	5600						
	49	49	3.3	28.12	3660	3900	5570	5600						
	54	44	3.4	25.75	3660	3900	5410	5600						
	58	41	3.3	23.59	3670	3900	5290	5600						
	64	37	3.4	21.73	3670	3900	5130	5600						
	69	35	3.4	20.09	3670	3900	5000	5600						
	74	32	3.3	18.54	3670	3900	4900	5600						
	18	133	0.8	51.03	1700	2500	3450	3900				SK 01 - 71L/6	15	42 - 43
	20	119	0.8	45.00	1860	2500	3500	3900						
	23	104	1.0	40.05	2000	2500	3550	3900						
24	99	0.9	58.50	2040	2500	3560	3900	SK 01 - 71S/4	14	42 - 43				
27	88	1.1	51.03	2120	2500	3590	3900							
31	77	1.3	45.00	2190	2500	3610	3900							
34	70	1.4	40.05	2230	2500	3620	3900							
38	63	1.6	36.00	2260	2500	3640	3900							
42	57	1.6	32.58	2290	2500	3650	3900							
47	51	1.7	29.61	2310	2500	3650	3900							
51	47	1.6	27.00	2320	2500	3580	3900							
56	43	1.6	24.75	2340	2500	3490	3900							
61	39	1.7	22.77	2350	2500	3400	3900							
66	36	1.7	20.97	2360	2500	3320	3900							
71	34	1.6	19.44	2360	2500	3250	3900							
77	31	1.6	18.00	2370	2500	3170	3900							
82	29	1.6	16.74	2370	2500	3110	3900							
83	29	3.2	16.90	2370	2500	3110	3900							
89	27	1.6	15.57	2370	2500	3030	3900							
95	25	4.0	14.74	2380	2500	2990	3900							
107	22	> 4.0	13.00	2300	2500	2880	3900							
120	20	> 4.0	11.57	2220	2500	2780	3900							
134	18	> 4.0	10.40	2140	2500	2690	3900							
150	16	> 4.0	9.41	2080	2500	2590	3900							
165	14	> 4.0	8.55	2020	2500	2520	3900							
181	13	> 4.0	7.80	1960	2500	2450	3900							
197	12	> 4.0	7.15	1900	2500	2380	3900							
214	11	> 4.0	6.58	1860	2500	2320	3900							
233	10	> 4.0	6.06	1810	2500	2260	3900							
251	10	> 4.0	5.62	1770	2500	2200	3900							
271	9	> 4.0	5.20	1720	2500	2150	3900							
291	8	> 4.0	4.84	1680	2500	2100	3900							
313	8	> 4.0	4.50	1650	2500	2050	3900							
327	7	> 4.0	4.31	1630	2500	2020	3900							
359	7	> 4.0	3.93	1580	2500	1960	3900							
392	6	> 4.0	3.60	1530	2500	1910	3900							
426	6	> 4.0	3.31	1490	2500	1860	3900							
462	5	> 4.0	3.05	1460	2500	1810	3900							
498	5	> 4.0	2.83	1420	2500	1770	3900							
538	4	> 4.0	2.62	1380	2500	1720	3900							
578	4	> 4.0	2.44	1350	2500	1690	3900							
624	4	> 4.0	2.26	1320	2500	1640	3900							
40	60	0.8	33.69	980	1620	2600	2500	SK 0 - 71S/4	11	42 - 43				
46	52	1.0	30.50	1050	1620	2630	2500							
50	48	1.0	27.77	1090	1620	2640	2500							
60	40	1.3	23.34	1140	1620	2670	2500							
69	35	1.3	19.92	1170	1620	2680	2500							
81	29	1.3	17.12	1200	1620	2690	2500							
91	26	1.9	15.12	1210	1620	2700	2500							
105	23	2.2	13.20	1220	1620	2700	2500							
118	20	2.5	11.66	1230	1620	2660	2500							
148	16	3.1	9.35	1230	1620	2480	2500							
163	15	3.4	8.47	1200	1620	2400	2500							
179	13	3.7	7.71	1170	1620	2340	2500							

1) bei / at / pour F_A = 0 N

2) bei / at / pour F_Q = 0 N

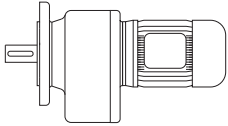

STIRNRADGETRIEBEMOTOREN HELICAL GEARED MOTORS MOTOREDUCTEURS A ENGRENAGES CYLINDRIQUES



DREHSTROM
THREE PHASE
A COURANT TRIPHASE

P _n [kW]	n ₂ [min ⁻¹]	M _a [Nm]	Standard f _B	i _{ges}	Normallagerung Normal bearing Roulement normal		Typenzusatz 5 Affix 5 Suffixe 5		Typ Type Type	ca. kg	Maße Dimens. Cotes
					F _{Q N} ¹⁾ [N]	F _{A N} ²⁾ [N]	F _Q ¹⁾ [N]	F _A ²⁾ [N]			
0.25	213	11	> 4.0	6.48	1110	1620	2210	2500	SK 0 - 71S/4	11	42 - 43
	250	10	> 4.0	5.53	1060	1620	2100	2500			
	291	8	> 4.0	4.75	1010	1620	2000	2500			
	309	8	> 4.0	4.46	990	1620	1970	2500			
	342	7	> 4.0	4.04	960	1620	1910	2500			
	375	6	> 4.0	3.68	930	1620	1850	2500			
	447	5	> 4.0	3.09	890	1620	1750	2500			
	523	5	> 4.0	2.64	840	1620	1660	2500			
	608	4	> 4.0	2.27	800	1620	1580	2500			
0.37	8.1	436	0.9	169.39	6740	7650	11050	9000	SK 300 - 71L/4	34	44 - 45
	9.1	388	1.0	151.51	6940	7650	11160	9000			
	10	350	1.0	136.61	7080	7650	11230	9000			
	11	318	1.3	124.00	7180	7650	11290	9000			
	12	285	1.4	110.91	7270	7650	11340	9000			
	14	256	1.3	100.00	7350	7650	11380	9000			
	15	232	1.7	90.77	7400	7650	11410	9000			
	11	315	1.0	122.88	4260	5600	7190	7650	SK 250 - 71L/4	23	44 - 45
	13	278	1.1	108.29	4430	5600	7290	7650			
	14	247	1.2	96.36	4560	5600	7370	7650			
	15	231	1.3	90.06	4620	5600	7410	7650			
	17	203	1.5	79.37	4710	5600	7460	7650			
	20	178	1.7	70.62	4770	5600	7510	7650			
	22	161	1.9	63.50	4820	5600	7530	7650			
	24	145	2.1	57.34	4850	5600	7550	7650			
15	236	0.8	61.80	2890	3900	5390	5600	SK 20 - 80S/6	20	42 - 43	
17	208	1.0	53.77	3090	3900	5470	5600				
18	196	1.0	76.50	3160	3900	5510	5600	SK 20 - 71L/4	18	42 - 43	
21	168	1.2	66.56	3310	3900	5570	5600				
22	161	1.2	61.80	3340	3900	5590	5600				
24	147	1.3	58.65	3400	3900	5620	5600				
26	136	1.5	53.77	3440	3900	5640	5600				
29	122	1.6	47.38	3490	3900	5660	5600				
33	107	1.9	42.13	3540	3900	5690	5600				
37	96	2.1	37.80	3570	3900	5700	5600				
40	88	2.2	34.09	3590	3900	5710	5600				
45	79	2.3	30.90	3610	3900	5570	5600				
49	72	2.3	28.12	3620	3900	5450	5600				
54	65	2.3	25.75	3630	3900	5290	5600				
58	61	2.2	23.59	3640	3900	5190	5600				
64	55	2.3	21.73	3650	3900	5030	5600				
69	51	2.3	20.09	3650	3900	4920	5600				
74	48	2.2	18.54	3660	3900	4810	5600				
27	131	0.8	51.03	1730	2500	3460	3900	SK 01 - 71L/4	15	42 - 43	
31	114	0.9	45.00	1910	2500	3520	3900				
34	104	1.0	40.05	2000	2500	3550	3900				
38	93	1.1	36.00	2090	2500	3580	3900				
42	84	1.1	32.58	2150	2500	3600	3900				
47	75	1.1	29.61	2200	2500	3520	3900				
51	69	1.1	27.00	2230	2500	3450	3900				
56	63	1.1	24.75	2260	2500	3360	3900				
61	58	1.1	22.77	2280	2500	3280	3900				
66	54	1.1	20.97	2300	2500	3210	3900				
71	50	1.1	19.44	2310	2500	3150	3900				
77	46	1.1	18.00	2330	2500	3080	3900				
82	43	1.1	16.74	2340	2500	3020	3900				
83	43	2.2	16.90	2340	2500	3040	3900				
89	40	1.1	15.57	2320	2500	2950	3900				
95	37	2.7	14.74	2310	2500	2920	3900				
107	33	3.0	13.00	2230	2500	2820	3900				
120	29	3.4	11.57	2160	2500	2730	3900				
134	26	3.8	10.40	2090	2500	2640	3900				
150	24	> 4.0	9.41	2020	2500	2550	3900				
165	21	> 4.0	8.55	1970	2500	2480	3900				

1) bei / at / pour F_A = 0 N

2) bei / at / pour F_Q = 0 N



STIRNRADGETRIEBEMOTOREN HELICAL GEARED MOTORS MOTOREDUCTEURS A ENGRENAGES CYLINDRIQUES

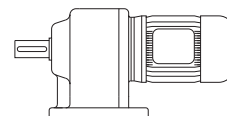

DREHSTROM
THREE PHASE
A COURANT TRIPHASE

P _n [kW]	n ₂ [min ⁻¹]	M _a [Nm]	Standard f _B	i _{ges}	Normallagerung Normal bearing Roulement normal		Typenzusatz 5 Affix 5 Suffixe 5		Typ Type Type	ca. kg	Maße Dimens. Cotes				
					F _{Q N} ¹⁾ [N]	F _{A N} ²⁾ [N]	F _Q ¹⁾ [N]	F _A ²⁾ [N]							
0.37	181	20	> 4.0	7.80	1910	2500	2410	3900	SK 01 - 71L/4	15	42 - 43				
	197	18	> 4.0	7.15	1870	2500	2350	3900							
	214	17	> 4.0	6.58	1820	2500	2290	3900							
	233	15	> 4.0	6.06	1780	2500	2230	3900							
	251	14	> 4.0	5.62	1740	2500	2180	3900							
	271	13	> 4.0	5.20	1690	2500	2130	3900							
	291	12	> 4.0	4.84	1660	2500	2080	3900							
	313	11	> 4.0	4.50	1620	2500	2030	3900							
	327	11	> 4.0	4.31	1600	2500	2010	3900							
	359	10	> 4.0	3.93	1560	2500	1950	3900							
	392	9	> 4.0	3.60	1520	2500	1900	3900							
	426	8	> 4.0	3.31	1480	2500	1850	3900							
	462	8	> 4.0	3.05	1440	2500	1800	3900							
	498	7	> 4.0	2.83	1410	2500	1760	3900							
	538	7	> 4.0	2.62	1370	2500	1710	3900							
	578	6	> 4.0	2.44	1340	2500	1670	3900							
	624	6	> 4.0	2.26	1310	2500	1630	3860							
		60	59	0.8	23.34	860	1620	2260				2500	SK 0 - 71L/4	12	42 - 43
		69	51	0.9	19.92	970	1620	2270				2500			
		81	44	0.9	17.12	1040	1620	2260				2500			
91		39	1.3	15.12	1150	1620	2640	2500							
105		34	1.5	13.20	1170	1620	2600	2500							
118		30	1.7	11.66	1190	1620	2570	2500							
148		24	2.1	9.35	1180	1620	2430	2500							
163		22	2.3	8.47	1150	1620	2360	2500							
179		20	2.5	7.71	1130	1620	2290	2500							
213		17	3.0	6.48	1070	1620	2170	2500							
250		14	3.5	5.53	1030	1620	2070	2500							
291		12	4.0	4.75	980	1620	1980	2500							
309		11	> 4.0	4.46	970	1620	1950	2500							
342		10	> 4.0	4.04	940	1620	1890	2500							
375		9	> 4.0	3.68	920	1620	1830	2500							
447		8	> 4.0	3.09	870	1620	1730	2500							
523		7	> 4.0	2.64	830	1610	1650	2500							
608		6	> 4.0	2.27	790	1530	1570	2500							
0.55		11	473	0.8	124.00	6570	7650	10960	9000	SK 300 - 80S/4	36	44 - 45			
		12	424	0.9	110.91	6790	7650	11080	9000						
		13	404	1.0	72.10	6880	7650	11120	9000	SK 30 - 80L/6	29	42 - 43			
		14	375	1.1	63.86	6990	7650	11180	9000						
		16	328	1.2	57.17	7150	7650	11270	9000						
		18	292	1.1	51.50	7260	7650	11330	9000						
		19	276	1.4	72.10	7300	7650	11350	9000						
		22	239	1.7	63.86	7390	7650	11400	9000	SK 30 - 80S/4	27	42 - 43			
		24	219	1.8	57.17	7430	7650	11130	9000						
		27	195	1.7	51.50	7480	7650	10770	9000						
		11	469	0.7	122.88	3140	5600	6590	7650						
		13	414	0.7	108.29	3630	5600	6830	7650	SK 250 - 80S/4	25	44 - 45			
		14	367	0.8	96.36	3960	5600	7020	7650						
		15	343	0.9	90.06	4110	5600	7100	7650						
		17	309	0.8	54.23	4290	5600	7210	7650						
		19	276	1.1	47.26	4440	5600	7300	7650	SK 25 - 80L/6	27	42 - 43			
		22	239	1.3	41.65	4590	5600	7390	7650						
		25	210	1.2	54.23	4680	5600	7450	7650						
		30	175	1.7	47.26	4780	5600	7510	7650	SK 25 - 80S/4	25	42 - 43			
		33	159	1.9	41.65	4820	5600	7530	7650						
38		138	2.2	37.06	4860	5600	7560	7650							
42		125	2.3	33.32	4890	5600	7580	7650							
22		239	0.8	61.80	2870	3900	5380	5600							
		26	202	1.0	53.77	3130	3900	5490	5600				SK 20 - 80S/4	20	42 - 43
	29	181	1.1	47.38	3240	3900	5540	5600							

1) bei / at / pour F_A = 0 N

2) bei / at / pour F_Q = 0 N

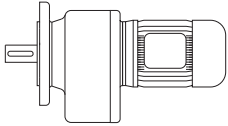

STIRNRADGETRIEBMOTOREN HELICAL GEARED MOTORS MOTOREDUCTEURS A ENGRENAGES CYLINDRIQUES



DREHSTROM
THREE PHASE
A COURANT TRIPHASE

P _n [kW]	n ₂ [min ⁻¹]	M _a [Nm]	Standard f _B	i _{ges}	Normallagerung Normal bearing Roulement normal		Typenzusatz 5 Affix 5 Suffixe 5		Typ Type Type	ca. kg	Maße Dimens. Cotes
					F _{Q N} ¹⁾ [N]	F _{A N} ²⁾ [N]	F _Q ¹⁾ [N]	F _A ²⁾ [N]			
0.55	33	159	1.3	42.13	3350	3900	5590	5600	SK 20 - 80S/4	20	42 - 43
	37	142	1.4	37.80	3420	3900	5630	5600			
	40	131	1.5	34.09	3460	3900	5540	5600			
	45	117	1.5	30.90	3510	3900	5360	5600			
	49	107	1.5	28.12	3540	3900	5250	5600			
	54	97	1.5	25.75	3570	3900	5110	5600			
	58	91	1.5	23.59	3580	3900	5000	5600			
	64	82	1.5	21.73	3600	3900	4880	5600			
	66	80	2.3	21.12	3600	3900	4860	5600			
	69	76	1.5	20.09	3610	3900	4770	5600			
	74	71	1.5	18.54	3620	3900	4680	5600			
	77	68	2.7	18.37	3620	3900	4660	5600			
	87	60	3.0	16.19	3500	3900	4500	5600			
	98	54	3.4	14.40	3380	3900	4340	5600			
	108	49	3.7	12.92	3290	3900	4220	5600			
	120	44	> 4.0	11.65	3190	3900	4090	5600			
	133	39	> 4.0	10.56	3100	3900	3970	5600			
	146	36	> 4.0	9.61	3020	3900	3860	5600			
	159	33	> 4.0	8.80	2940	3900	3750	5600			
	174	30	> 4.0	8.06	2870	3900	3650	5600			
	188	28	> 4.0	7.43	2800	3900	3570	5600			
	204	26	> 4.0	6.86	2730	3900	3480	5600			
	213	25	> 4.0	6.58	2700	3900	3440	5600			
	221	24	> 4.0	6.34	2660	3900	3400	5600			
	241	22	> 4.0	5.80	2610	3900	3310	5600			
	272	19	> 4.0	5.15	2510	3900	3200	5600			
	303	17	> 4.0	4.62	2430	3900	3080	5600			
	336	16	> 4.0	4.17	2350	3900	2980	5600			
	370	14	> 4.0	3.78	2290	3900	2890	5600			
	407	13	> 4.0	3.44	2220	3900	2810	5600			
	444	12	> 4.0	3.15	2160	3900	2730	5600			
	484	11	> 4.0	2.89	2100	3900	2660	5600			
	526	10	> 4.0	2.66	2040	3900	2590	5600			
569	9	> 4.0	2.46	1990	3900	2520	5510				
617	9	> 4.0	2.27	1940	3820	2460	5320				
	44	119	0.8	31.20	1770	2500	3360	3900	SK 01 V - 80S/4	17	42 - 43
	49	107	0.9	28.24	1960	2500	3280	3900			
	54	97	1.0	25.66	2060	2500	3210	3900			
	59	89	1.1	23.40	2120	2500	3140	3900			
	64	82	1.2	21.45	2160	2500	3090	3900			
	70	75	1.2	19.73	2200	2500	3010	3900			
	77	68	1.3	18.17	2240	2500	2950	3900			
	83	63	1.5	16.90	2260	2500	2930	3900	SK 01 - 80S/4	17	42 - 43
	95	55	1.8	14.74	2200	2500	2830	3900			
	107	49	2.0	13.00	2140	2500	2730	3900			
	120	44	2.3	11.57	2070	2500	2650	3900			
	134	39	2.6	10.40	2020	2500	2570	3900			
	150	35	2.9	9.41	1950	2500	2490	3900			
	165	32	3.1	8.55	1900	2500	2420	3900			
	181	29	3.4	7.80	1860	2500	2350	3900			
	197	27	3.8	7.15	1810	2500	2290	3900			
	214	25	4.0	6.58	1770	2500	2240	3900			
	233	23	4.0	6.06	1730	2500	2180	3900			
	251	21	> 4.0	5.62	1690	2500	2140	3900			
	271	19	> 4.0	5.20	1660	2500	2090	3900			
	291	18	4.0	4.84	1620	2500	2040	3900			
	313	17	4.0	4.50	1580	2500	1990	3900			
	327	16	> 4.0	4.31	1580	2500	1980	3900			
	359	15	> 4.0	3.93	1530	2500	1920	3900			
	392	13	> 4.0	3.60	1490	2500	1870	3900			
	426	12	> 4.0	3.31	1450	2500	1830	3900			
	462	11	> 4.0	3.05	1420	2500	1780	3900			
	498	11	> 4.0	2.83	1380	2500	1730	3900			
	538	10	> 4.0	2.62	1350	2500	1690	3900			
	578	9	> 4.0	2.44	1320	2450	1650	3830			
	624	8	> 4.0	2.26	1290	2380	1620	3720			

1) bei / at / pour F_A = 0 N

2) bei / at / pour F_Q = 0 N



STIRNRADGETRIEBEMOTOREN HELICAL GEARED MOTORS MOTOREDUCTEURS A ENGRENAGES CYLINDRIQUES

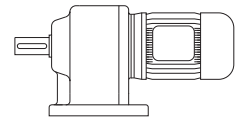

DREHSTROM
THREE PHASE
A COURANT TRIPHASE

P _n [kW]	n ₂ [min ⁻¹]	M _a [Nm]	Standard f _B	i _{ges}	Normallagerung Normal bearing Roulement normal		Typenzusatz 5 Affix 5 Suffixe 5		Typ Type Type	ca. kg	Maße Dimens. Cotes	
					F _{Q N} ¹⁾ [N]	F _{A N} ²⁾ [N]	F _Q ¹⁾ [N]	F _A ²⁾ [N]				
0.55	91	58	0.9	15.12	800	1620	2000	2500	SK 0 - 80S/4	14	42 - 43	
	105	50	1.0	13.20	950	1620	2060	2500				
	118	45	1.1	11.66	1000	1620	2060	2500				
	148	35	1.4	9.35	1120	1620	2100	2500				
	163	32	1.6	8.47	1090	1620	2080	2500				
	179	29	1.7	7.71	1070	1620	2070	2500				
	213	25	2.0	6.48	1020	1620	2000	2500				
	250	21	2.4	5.53	980	1620	1960	2500				
	291	18	2.7	4.75	940	1580	1910	2500				
	309	17	2.9	4.46	940	1620	1910	2500				
	342	15	3.3	4.04	910	1620	1850	2500				
	375	14	3.6	3.68	890	1610	1800	2500				
	447	12	4.3	3.09	840	1520	1700	2500				
	523	10	5.0	2.64	810	1460	1620	2500				
	608	9	5.4	2.27	770	1390	1550	2370				
	0.75	16	459	1.5	89.63	9530	9000	14200				12000
18		407	1.7	79.63	9660	9000	13940	12000				
20		365	1.9	71.29	9750	9000	13530	12000				
22		329	2.1	64.24	9820	9000	13140	12000				
24		298	2.3	58.20	9870	9000	12800	12000				
26		271	2.6	52.96	9910	9000	12450	12000				
		15	471	0.8	90.77	6580	7650	10970	9000	SK 300 - 80L/4	38	44 - 45
		17	429	0.9	82.86	6770	7650	11070	9000			
		18	394	1.0	76.00	6920	7650	11140	9000			
		19	377	1.0	72.10	6980	7650	11180	9000	SK 30 - 80L/4	29	42 - 43
		22	326	1.2	63.86	7150	7650	11110	9000			
		24	298	1.3	57.17	7240	7650	10870	9000			
		27	265	1.3	51.50	7330	7650	10510	9000			
		30	239	1.7	47.68	7390	7650	10210	9000			
		33	217	1.8	42.68	7430	7650	9940	9000			
		37	194	1.7	38.45	7480	7650	9650	9000			
	40	179	2.2	34.91	7500	7650	9410	9000				
	44	163	2.4	31.84	7530	7650	9140	9000				
	48	149	2.7	29.22	7550	7650	8920	9000				
	20	362	0.8	70.62	3990	5600	7030	7650	SK 250 - 80L/4	27	44 - 45	
	22	326	0.9	63.50	4200	5600	7150	7650				
	24	295	1.0	57.34	4360	5600	7250	7650				
	25	286	0.9	54.23	4400	5600	7270	7650	SK 25 - 80L/4	27	42 - 43	
	30	239	1.3	47.26	4590	5600	7390	7650				
	33	217	1.4	41.65	4660	5600	7430	7650				
	38	188	1.6	37.06	4750	5600	7490	7650				
	42	171	1.7	33.32	4790	5600	7520	7650				
	46	156	1.9	30.53	4830	5600	7540	7650				
	52	138	2.2	27.16	4860	5600	7560	7650				
	58	123	2.4	24.42	4890	5600	7580	7650				
	64	112	2.7	22.05	4910	5600	7520	7650				
	71	101	3.0	20.00	4930	5600	7280	7650				
	26	275	0.7	53.77	2550	3900	5250	5600				SK 20 - 80L/4
	29	247	0.8	47.38	2810	3900	5350	5600				
	33	217	0.9	42.13	3030	3900	5450	5600				
	37	194	1.0	37.80	3170	3900	5350	5600				
	40	179	1.1	34.09	3250	3900	5260	5600				
	45	159	1.1	30.90	3350	3900	5120	5600				
	49	146	1.1	28.12	3410	3900	5030	5600				
	54	133	1.1	25.75	3450	3900	4900	5600				
	58	123	1.1	23.59	3490	3900	4820	5600				
	64	112	1.1	21.73	3520	3900	4700	5600				
	66	109	1.7	21.12	3530	3900	4710	5600				
	69	104	1.1	20.09	3520	3900	4610	5600				
	74	97	1.1	18.54	3460	3900	4520	5600				
	77	93	2.0	18.37	3470	3900	4530	5600				
	87	82	2.2	16.19	3380	3900	4380	5600				

1) bei / at / pour F_A = 0 N

2) bei / at / pour F_Q = 0 N

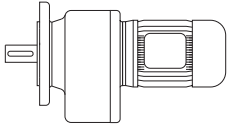

STIRNRADGETRIEBEMOTOREN HELICAL GEARED MOTORS MOTOREDUCTEURS A ENGRENAGES CYLINDRIQUES



DREHSTROM
THREE PHASE
A COURANT TRIPHASE

P _n [kW]	n ₂ [min ⁻¹]	M _a [Nm]	Standard f _B	i _{ges}	Normallagerung Normal bearing Roulement normal		Typenzusatz 5 Affix 5 Suffixe 5		Typ Type Type	ca. kg	Maße Dimens. Cotes				
					F _{Q N} ¹⁾ [N]	F _{A N} ²⁾ [N]	F _Q ¹⁾ [N]	F _A ²⁾ [N]							
0.75	98	73	2.5	14.40	3280	3900	4240	5600	SK 20 - 80L/4	22	42 - 43				
	108	66	2.7	12.92	3190	3900	4130	5600							
	120	60	3.0	11.65	3100	3900	4000	5600							
	133	54	3.0	10.56	3020	3900	3890	5600							
	146	49	3.0	9.61	2940	3900	3790	5600							
	159	45	3.0	8.80	2870	3900	3690	5600							
	174	41	3.0	8.06	2800	3900	3590	5600							
	188	38	3.0	7.43	2740	3900	3510	5600							
	204	35	3.0	6.86	2680	3900	3430	5600							
	213	34	4.0	6.58	2660	3900	3390	5600							
	221	32	3.0	6.34	2620	3900	3340	5600							
	241	30	> 4.0	5.80	2560	3900	3270	5600							
	272	26	> 4.0	5.15	2470	3900	3150	5600							
	303	24	> 4.0	4.62	2390	3900	3050	5600							
	336	21	> 4.0	4.17	2320	3900	2950	5600							
	370	19	> 4.0	3.78	2260	3900	2870	5600							
	407	18	> 4.0	3.44	2190	3900	2780	5600							
	444	16	> 4.0	3.15	2130	3900	2710	5600							
	484	15	> 4.0	2.89	2070	3900	2640	5600							
	526	14	> 4.0	2.66	2020	3900	2560	5540							
	569	13	> 4.0	2.46	1970	3800	2500	5370							
	617	12	> 4.0	2.27	1920	3680	2440	5190							
		54	133	0.8	25.66	460	1980	2370				3900	SK 01 V - 80L/4	19	42 - 43
		59	121	0.8	23.40	690	2120	2480				3900			
		64	112	0.9	21.45	850	2190	2520				3900			
	70	102	0.9	19.73	1030	2280	2590	3900							
	77	93	0.9	18.17	1190	2350	2640	3900							
	83	86	1.1	16.90	2120	2500	2800	3900	SK 01 - 80L/4	19	42 - 43				
	95	75	1.3	14.74	2080	2500	2710	3900							
	107	67	1.5	13.00	2030	2500	2630	3900							
	120	60	1.7	11.57	1980	2500	2550	3900							
	134	53	1.9	10.40	1930	2500	2490	3900							
	150	48	2.1	9.41	1870	2500	2410	3900							
	165	43	2.3	8.55	1830	2500	2360	3900							
	181	40	2.5	7.80	1790	2500	2290	3900							
	197	36	2.8	7.15	1760	2500	2240	3900							
	214	33	3.0	6.58	1720	2500	2190	3900							
	233	31	3.0	6.06	1680	2500	2140	3900							
	251	29	3.0	5.62	1640	2500	2090	3900							
	271	26	3.0	5.20	1610	2500	2050	3900							
	291	25	3.0	4.84	1570	2500	2000	3900							
	313	23	3.0	4.50	1540	2500	1960	3900							
	327	22	> 4.0	4.31	1540	2500	1940	3900							
	359	20	> 4.0	3.93	1500	2500	1890	3900							
	392	18	> 4.0	3.60	1460	2500	1850	3900							
	426	17	> 4.0	3.31	1420	2500	1790	3900							
	462	16	> 4.0	3.05	1390	2460	1750	3900							
	498	14	> 4.0	2.83	1360	2430	1720	3900							
	538	13	> 4.0	2.62	1330	2370	1670	3800							
	578	12	> 4.0	2.44	1300	2310	1640	3710							
	624	11	> 4.0	2.26	1280	2250	1600	3590							
	118	61	0.8	11.66	330	1060	1500	2500	SK 0 - 80L/4	16	42 - 43				
	148	48	1.0	9.35	600	1220	1630	2500							
	163	44	1.1	8.47	650	1230	1650	2500							
	179	40	1.2	7.71	710	1260	1660	2500							
	213	34	1.5	6.48	780	1270	1650	2500							
	250	29	1.7	5.53	830	1270	1650	2500							
	291	25	2.0	4.75	860	1240	1620	2500							
	309	23	2.2	4.46	900	1440	1800	2500							
	342	21	2.4	4.04	880	1410	1760	2500							
	375	19	2.6	3.68	860	1400	1750	2500							
	447	16	3.1	3.09	820	1350	1680	2450							
	523	14	3.7	2.64	780	1280	1600	2310							
	608	12	4.0	2.27	750	1230	1520	2210							

1) bei / at / pour F_A = 0 N

2) bei / at / pour F_Q = 0 N



STIRNRADGETRIEBEMOTOREN HELICAL GEARED MOTORS MOTOREDUCTEURS A ENGRENAGES CYLINDRIQUES

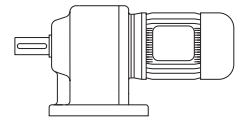

DREHSTROM
THREE PHASE
A COURANT TRIPHASE

P _n [kW]	n ₂ [min ⁻¹]	M _a [Nm]	Standard f _B	i _{ges}	Normallagerung Normal bearing Roulement normal		Typenzusatz 5 Affix 5 Suffixe 5		Typ Type Type	ca. kg	Maße Dimens. Cotes
					F _{Q N} ¹⁾ [N]	F _{A N} ²⁾ [N]	F _Q ¹⁾ [N]	F _A ²⁾ [N]			
1.10	16	673	1.0	89.63	8820	9000	13570	12000	SK 330 - 90S/4	51	44 - 45
	18	597	1.2	79.63	9110	9000	13200	12000			
	20	536	1.3	71.29	9310	9000	12880	12000			
	22	482	1.5	64.24	9470	9000	12560	12000			
	24	438	1.6	58.20	9590	9000	12260	12000			
	25	420	1.6	55.78	9630	9000	12210	12000	SK 33 - 90S/4	39	42 - 43
	29	362	1.9	48.50	9760	9000	11750	12000			
	33	318	2.2	42.68	9840	9000	11340	12000			
	37	284	2.3	37.93	9890	9000	11000	12000			
	41	256	2.3	33.95	9810	9000	10700	12000			
	46	228	2.3	30.56	9500	9000	10350	12000			
	50	210	2.3	27.74	9280	9000	10130	12000			
	22	478	0.8	63.86	6540	7650	10540	9000	SK 30 - 90S/4	31	42 - 43
	24	438	0.9	57.17	6730	7650	10330	9000			
	27	389	0.9	51.50	6930	7650	10050	9000			
	30	350	1.1	47.68	7080	7650	9800	9000			
	33	318	1.3	42.68	7180	7650	9570	9000			
	37	284	1.2	38.45	7280	7650	9290	9000			
	40	263	1.5	34.91	7330	7650	9100	9000			
	44	239	1.7	31.84	7390	7650	8860	9000			
	48	219	1.8	29.22	7430	7650	8660	9000			
	52	202	2.0	26.92	7460	7650	8460	9000			
	57	184	2.0	24.89	7500	7650	8250	9000			
	61	172	2.0	23.08	7480	7650	8090	9000			
	66	159	2.0	21.46	7310	7650	7910	9000			
	30	350	0.9	47.26	4070	5600	7080	7650	SK 25 - 90S/4	29	42 - 43
	33	318	0.9	41.65	4240	5600	7180	7650			
	38	276	1.1	37.06	4440	5600	7300	7650			
42	250	1.2	33.32	4550	5600	7360	7650				
46	228	1.3	30.53	4630	5600	7410	7650				
52	202	1.5	27.16	4710	5600	7460	7650				
58	181	1.7	24.42	4770	5600	7450	7650				
64	164	1.8	22.05	4810	5600	7270	7650				
71	148	2.0	20.00	4840	5600	7060	7650				
77	136	2.0	18.27	4870	5600	6900	7650				
84	125	2.0	16.75	4890	5600	6730	7650				
43	244	0.8	32.72	1960	3900	4710	5600	SK 20 V - 90S/4	27	42 - 43	
45	233	0.9	30.90	2480	3900	4750	5600				
48	219	0.9	29.33	2290	3900	4670	5600				
51	206	1.0	27.23	2830	3900	4640	5600				
53	198	1.0	26.46	2540	3900	4590	5600				
57	184	1.1	24.21	3070	3900	4540	5600				
64	164	1.2	21.73	3260	3900	4440	5600				
66	159	1.2	21.12	3320	3900	4430	5600	SK 20 - 90S/4	24	42 - 43	
77	136	1.3	18.37	3240	3900	4290	5600				
87	121	1.5	16.19	3160	3900	4180	5600				
98	107	1.7	14.40	3080	3900	4050	5600				
108	97	1.9	12.92	3010	3900	3960	5600				
120	88	2.1	11.65	2940	3900	3850	5600				
133	79	2.1	10.56	2870	3900	3750	5600				
146	72	2.1	9.61	2810	3900	3670	5600				
159	66	2.1	8.80	2750	3900	3570	5600				
174	60	2.1	8.06	2690	3900	3490	5600				
188	56	2.1	7.43	2640	3900	3420	5600				
204	51	2.1	6.86	2590	3900	3330	5600				
213	49	2.7	6.58	2570	3900	3320	5600				
221	48	2.1	6.34	2520	3900	3260	5600				
241	44	3.1	5.80	2480	3900	3190	5600				
272	39	3.2	5.15	2400	3900	3080	5600				
303	35	3.2	4.62	2330	3900	2990	5600				
336	31	3.2	4.17	2270	3900	2900	5600				
370	28	3.2	3.78	2200	3900	2820	5600				
407	26	3.2	3.44	2140	3900	2740	5600				
444	24	3.2	3.15	2080	3900	2660	5600				
484	22	3.1	2.89	2030	3800	2590	5460				

1) bei / at / pour F_A = 0 N

2) bei / at / pour F_Q = 0 N

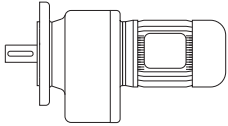

STIRNRADGETRIEBEMOTOREN HELICAL GEARED MOTORS MOTOREDUCTEURS A ENGRENAGES CYLINDRIQUES



DREHSTROM
THREE PHASE
A COURANT TRIPHASE

P _n [kW]	n ₂ [min ⁻¹]	M _a [Nm]	Standard f _B	i _{ges}	Normallagerung Normal bearing Roulement normal		Typenzusatz 5 Affix 5 Suffixe 5		Typ Type Type	ca. kg	Maße Dimens. Cotes			
					F _{Q N} ¹⁾ [N]	F _{A N} ²⁾ [N]	F _Q ¹⁾ [N]	F _A ²⁾ [N]						
1.10	526	20	3.2	2.66	1980	3710	2530	5320	SK 20 - 90S/4	24	42 - 43			
	569	18	3.1	2.46	1940	3610	2470	5160						
	617	17	3.2	2.27	1890	3490	2410	4980						
	95	111	0.9	14.74	800	1860	2260	3900				SK 01 - 90S/4	21	42 - 43
	107	98	1.0	13.00	1060	2010	2370	3900						
	120	88	1.1	11.57	1210	2080	2390	3900						
	134	78	1.3	10.40	1400	2190	2340	3900						
	150	70	1.4	9.41	1500	2210	2280	3900						
	165	64	1.6	8.55	1560	2210	2230	3900						
	181	58	1.7	7.80	1630	2230	2180	3900						
	197	53	1.9	7.15	1650	2250	2140	3900						
	214	49	2.0	6.58	1610	2230	2090	3900						
	233	45	2.0	6.06	1580	2210	2050	3900						
	251	42	2.0	5.62	1550	2190	2010	3900						
	271	39	2.0	5.20	1520	2150	1970	3900						
	291	36	2.0	4.84	1500	2140	1930	3900						
	313	34	2.0	4.50	1470	2080	1890	3830						
	327	32	2.8	4.31	1470	2350	1890	3900						
	359	29	2.8	3.93	1440	2320	1840	3900						
	392	27	2.8	3.60	1400	2250	1790	3860						
426	25	2.8	3.31	1370	2210	1750	3750							
462	23	2.8	3.05	1340	2170	1710	3660							
498	21	2.8	2.83	1320	2120	1670	3590							
538	20	2.8	2.62	1280	2060	1630	3460							
578	18	2.8	2.44	1260	2040	1600	3410							
624	17	2.8	2.26	1230	1980	1560	3310							
1.50	16	918	0.8	89.63	7530	9000	12630	12000	SK 330 - 90L/4	55	44 - 45			
	18	814	0.9	79.63	8150	9000	12400	12000						
	20	731	1.0	71.29	8570	9000	12140	12000						
	22	657	1.1	64.24	8880	9000	11870	12000						
	24	597	1.2	58.20	9110	9000	11630	12000						
	25	573	1.2	55.78	9190	9000	11630	12000	SK 33 - 90L/4	43	42 - 43			
	29	494	1.4	48.50	9440	9000	11260	12000						
	33	434	1.6	42.68	9600	9000	10920	12000						
	37	387	1.7	37.93	9670	9000	10610	12000						
	41	349	1.7	33.95	9440	9000	10340	12000						
	46	311	1.7	30.56	9180	9000	10040	12000						
	50	286	1.7	27.74	8980	9000	9820	12000						
	56	256	1.7	25.22	8710	9000	9520	12000						
	61	235	1.7	23.09	8510	9000	9290	12000						
	66	217	1.7	21.15	8340	9000	9090	12000						
	73	196	1.7	19.40	8110	9000	8840	12000						
	27	531	0.8	51.46	6250	7650	9520	9000	SK 30 V - 90L/4	38	42 - 43			
	30	478	0.8	47.68	6540	7650	9330	9000	SK 30 - 90L/4	35	42 - 43			
	33	434	0.9	42.68	6750	7650	9140	9000						
	37	387	0.9	38.45	6940	7650	8930	9000						
40	358	1.1	34.91	7050	7650	8730	9000							
44	326	1.2	31.84	7150	7650	8540	9000							
48	298	1.3	29.22	7240	7650	8360	9000							
52	275	1.5	26.92	7300	7650	8210	9000							
57	251	1.5	24.89	7360	7650	8000	9000							
61	235	1.5	23.08	7220	7650	7850	9000							
66	217	1.5	21.46	7080	7650	7690	9000							
66	217	1.8	21.28	7140	7650	7740	9000							
71	202	1.5	20.00	6950	7650	7550	9000							
75	191	2.1	18.85	6910	7650	7480	9000							
84	171	2.3	16.87	6670	7650	7240	9000							
93	154	2.2	15.20	6500	7650	7030	9000							
103	139	2.7	13.80	6320	7650	6850	9000							
46	311	1.0	30.53	4280	5600	7200	7650	SK 25 - 90L/4	33	42 - 43				
52	275	1.1	27.16	4450	5600	7300	7650							
58	247	1.2	24.42	4560	5600	7150	7650							
64	224	1.3	22.05	4640	5600	6980	7650							

1) bei / at / pour F_A = 0 N

2) bei / at / pour F_Q = 0 N



STIRNRADGETRIEBEMOTOREN HELICAL GEARED MOTORS MOTOREDUCTEURS A ENGRENAGES CYLINDRIQUES

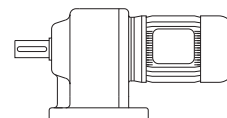

DREHSTROM
THREE PHASE
A COURANT TRIPHASE

P _n [kW]	n ₂ [min ⁻¹]	M _a [Nm]	Standard f _B	i _{ges}	Normallagerung Normal bearing Roulement normal		Typenzusatz 5 Affix 5 Suffixe 5		Typ Type Type	ca. kg	Maße Dimens. Cotes
					F _{Q N} ¹⁾ [N]	F _{A N} ²⁾ [N]	F _Q ¹⁾ [N]	F _A ²⁾ [N]			
1.50	71	202	1.5	20.00	4710	5600	6810	7650	SK 25 - 90L/4	33	42 - 43
	77	186	1.5	18.27	4750	5600	6660	7650			
	80	179	1.4	17.61	4770	5600	6640	7650			
	84	171	1.5	16.75	4790	5600	6530	7650			
	91	157	1.9	15.35	4780	5600	6420	7650			
	104	138	2.2	13.52	4610	5600	6200	7650			
	116	123	2.4	12.03	4490	5600	6020	7650			
	129	111	2.7	10.82	4360	5600	5840	7650			
	145	99	3.0	9.77	4230	5600	5650	7650			
	160	90	3.3	8.86	4120	5600	5490	7650			
	176	81	3.3	8.09	4010	5600	5340	7650			
	191	75	3.3	7.42	3930	5600	5210	7650			
	208	69	3.3	6.82	3830	5600	5080	7650			
	66	217	0.9	21.12	1920	3490	4120	5600			
	77	186	1.0	18.37	2370	3740	4010	5600			
	87	165	1.1	16.19	2600	3900	3930	5600			
	98	146	1.2	14.40	2810	3900	3840	5600			
	108	133	1.4	12.92	2800	3900	3760	5600			
	120	119	1.5	11.65	2760	3900	3670	5600			
	133	108	1.5	10.56	2700	3900	3590	5600			
146	98	1.5	9.61	2660	3900	3510	5600				
159	90	1.5	8.80	2610	3900	3440	5600				
174	82	1.5	8.06	2560	3900	3360	5600				
188	76	1.5	7.43	2510	3900	3290	5600				
204	70	1.5	6.86	2470	3860	3220	5600				
213	67	2.0	6.58	2470	3900	3220	5600				
221	65	1.5	6.34	2420	3780	3160	5600				
241	59	2.2	5.80	2400	3900	3120	5600				
272	53	2.3	5.15	2320	3900	3010	5600				
303	47	2.3	4.62	2260	3900	2920	5600				
336	43	2.3	4.17	2200	3900	2840	5600				
370	39	2.3	3.78	2140	3820	2770	5600				
407	35	2.3	3.44	2090	3720	2690	5510				
444	32	2.3	3.15	2040	3630	2620	5350				
484	30	2.3	2.89	1990	3500	2550	5160				
526	27	2.3	2.66	1940	3450	2490	5060				
569	25	2.3	2.46	1900	3340	2430	4910				
617	23	2.3	2.27	1850	3250	2380	4760				
120	119	0.8	11.57	-	-	1480	3380				
134	107	0.9	10.40	110	1090	1600	3450				
150	96	1.0	9.41	340	1210	1700	3490				
165	87	1.2	8.55	520	1310	1780	3490				
181	79	1.3	7.80	680	1400	1840	3520				
197	73	1.4	7.15	770	1430	1870	3490				
214	67	1.5	6.58	870	1480	1890	3450				
233	61	1.5	6.06	990	1530	1940	3450				
251	57	1.5	5.62	1010	1530	1910	3390				
271	53	1.5	5.20	1050	1530	1880	3340				
291	49	1.5	4.84	1100	1550	1850	3310				
313	46	1.5	4.50	1120	1530	1810	3240				
327	44	2.0	4.31	1400	1880	1820	3590				
359	40	2.0	3.93	1370	1880	1770	3520				
392	37	2.0	3.60	1340	1840	1730	3430				
426	34	2.0	3.31	1310	1830	1700	3360				
462	31	2.0	3.05	1290	1820	1660	3310				
498	29	2.0	2.83	1260	1780	1620	3220				
538	27	2.0	2.62	1240	1750	1590	3150				
578	25	2.0	2.44	1220	1730	1560	3090				
624	23	2.0	2.26	1190	1700	1520	3020				
2.20	25	840	0.8	55.78	7770	9000	10520	12000	SK 33 - 100L/4	49	42 - 43
	29	724	1.0	48.50	8600	9000	10380	12000			
	33	637	1.1	42.68	8960	9000	10130	12000			
	37	568	1.1	37.93	8950	9000	9950	12000			
	41	512	1.1	33.95	8770	9000	9720	12000			
	46	457	1.1	30.56	8580	9000	9470	12000			
	50	420	1.1	27.74	8440	9000	9300	12000			

1) bei / at / pour F_A = 0 N

2) bei / at / pour F_Q = 0 N

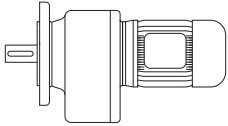

STIRNRADGETRIEBEMOTOREN HELICAL GEARED MOTORS MOTOREDUCTEURS A ENGRENAGES CYLINDRIQUES



DREHSTROM
THREE PHASE
A COURANT TRIPHASE

P _n [kW]	n ₂ [min ⁻¹]	M _a [Nm]	Standard f _B	i _{ges}	Normallagerung Normal bearing Roulement normal		Typenzusatz 5 Affix 5 Suffixe 5		Typ Type Type	ca. kg	Maße Dimens. Cotes			
					F _{Q N} ¹⁾ [N]	F _{A N} ²⁾ [N]	F _Q ¹⁾ [N]	F _A ²⁾ [N]						
2.20	56	375	1.2	25.22	8220	9000	9050	12000	SK 33 - 100L/4	49	42 - 43			
	61	344	1.1	23.09	8080	9000	8870	12000						
	66	318	1.1	21.15	7920	9000	8690	12000						
	73	288	1.2	19.40	7750	9000	8480	12000						
	79	266	1.2	17.87	7580	9000	8300	12000						
	85	247	1.1	16.49	7440	9000	8150	12000						
	41	512	0.8	34.39	5980	7650	7620	9000				SK 30 V - 100L/4	44	42 - 43
	45	467	0.9	31.54	6400	7650	7900	9000						
	49	429	0.9	29.05	6710	7650	7780	9000						
	52	404	1.0	26.89	6820	7650	7680	9000						
56	375	1.0	24.90	6890	7650	7550	9000							
60	350	1.0	23.16	6800	7650	7440	9000							
66	318	1.2	21.28	6760	7650	7370	9000	SK 30 - 100L/4	41	42 - 43				
75	280	1.4	18.85	6540	7650	7140	9000							
84	250	1.6	16.87	6390	7650	6950	9000							
93	226	1.5	15.20	6220	7650	6770	9000							
103	204	1.9	13.80	6060	7650	6590	9000							
113	186	2.0	12.59	5940	7650	6430	9000							
123	171	2.2	11.55	5790	7650	6290	9000							
133	158	2.3	10.64	5670	7650	6150	9000							
80	263	1.0	17.61	4230	5600	6250	7650				SK 25 - 100L/4	39	42 - 43	
91	231	1.3	15.35	4430	5600	6090	7650							
104	202	1.5	13.52	4320	5600	5910	7650							
116	181	1.7	12.03	4220	5600	5750	7650							
129	163	1.8	10.82	4130	5600	5610	7650							
145	145	2.1	9.77	4010	5600	5440	7650							
160	131	2.2	8.86	3930	5600	5310	7650							
176	119	2.2	8.09	3840	5600	5160	7650							
191	110	2.2	7.42	3760	5600	5060	7650							
208	101	2.2	6.82	3670	5600	4930	7650							
226	93	2.2	6.29	3600	5510	4820	7650							
244	86	2.2	5.82	3520	5430	4710	7650							
264	80	2.2	5.38	3450	5290	4600	7650							
284	74	2.2	5.00	3380	5210	4510	7650							
306	69	2.2	4.64	3310	5110	4410	7430							
323	65	2.2	4.33	3260	5010	4340	7300							
352	60	2.2	4.03	3180	4870	4240	7080							
376	56	2.2	3.75	3120	4770	4160	6920							
408	51	3.0	3.48	3080	5110	4080	7190							
442	48	3.0	3.21	3000	4950	3990	6980							
477	44	3.0	2.98	2940	4830	3890	6780							
516	41	3.0	2.75	2870	4710	3800	6590							
557	38	3.0	2.55	2800	4580	3710	6400							
599	35	3.0	2.37	2750	4480	3630	6250							
643	33	3.0	2.21	2690	4350	3550	6060							
689	30	3.0	2.06	2630	4270	3480	5930							
729	29	3.0	1.92	2580	4170	3410	5770							
87	241	0.8	16.19	-	-	2500	4660	SK 20 - 100L/4	34	42 - 43				
98	214	0.8	14.40	460	1760	2790	4860							
108	195	0.9	12.92	750	1930	2940	4950							
120	175	1.0	11.65	1080	2140	3110	5010							
133	158	1.0	10.56	1330	2300	3210	5060							
146	144	1.0	9.61	1500	2390	3250	5060							
159	132	1.0	8.80	1650	2460	3200	5060							
174	121	1.0	8.06	1750	2520	3130	5010							
188	112	1.0	7.43	1840	2540	3090	4950							
204	103	1.0	6.86	1910	2570	3030	4910							
213	99	1.3	6.58	2290	3340	3050	5600							
221	95	1.0	6.34	1980	2590	2980	4860							
241	87	1.5	5.80	2240	3360	2960	5600							
272	77	1.6	5.15	2180	3340	2880	5440							
303	69	1.6	4.62	2140	3310	2800	5320							
336	63	1.6	4.17	2080	3240	2730	5160							
370	57	1.6	3.78	2040	3190	2660	5060							
407	52	1.6	3.44	1990	3130	2600	4910							
444	47	1.6	3.15	1950	3090	2530	4800							

1) bei / at / pour F_A = 0 N

2) bei / at / pour F_Q = 0 N



STIRNRADGETRIEBEMOTOREN HELICAL GEARED MOTORS MOTOREDUCTEURS A ENGRENAGES CYLINDRIQUES

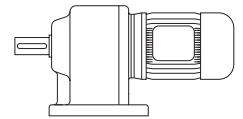

DREHSTROM
THREE PHASE
A COURANT TRIPHASE

P _n [kW]	n ₂ [min ⁻¹]	M _a [Nm]	Standard f _B	i _{ges}	Normallagerung Normal bearing Roulement normal		Typenzusatz 5 Affix 5 Suffixe 5		Typ Type Type	ca. kg	Maße Dimens. Cotes
					F _{Q N} ¹⁾ [N]	F _{A N} ²⁾ [N]	F _Q ¹⁾ [N]	F _A ²⁾ [N]			
2.20	484	43	1.6	2.89	1910	3030	2470	4680	SK 20 - 100L/4	34	42 - 43
	526	40	1.6	2.66	1860	2960	2420	4540			
	569	37	1.6	2.46	1830	2900	2360	4430			
	617	34	1.6	2.27	1790	2840	2310	4320			
3.00	41	699	0.9	34.50	6560	9000	8890	12000	SK 33 V - 100L/40	57	42 - 43
	46	623	1.1	30.36	7210	9000	8860	12000			
	52	551	1.1	26.98	7800	9000	8690	12000			
	59	486	1.1	24.15	7640	9000	8480	12000			
	65	441	1.1	21.74	7510	9000	8310	12000			
	72	398	1.1	19.73	7360	9000	8120	12000	SK 33 - 100L/40	51	42 - 43
	79	363	1.4	17.94	7280	9000	8030	12000			
	94	305	1.6	15.60	7020	9000	7710	12000			
	106	270	1.8	13.73	6820	9000	7490	12000			
	119	241	2.0	12.20	6630	9000	7270	12000			
	133	215	2.2	10.92	6460	9000	7070	12000			
	148	194	2.5	9.83	6280	9000	6860	12000			
	167	172	2.5	8.67	6100	9000	6660	12000			
	188	152	2.8	7.70	5930	9000	6450	12000			
66	434	0.9	21.28	6040	7650	6930	9000				
75	382	1.0	18.85	6160	7650	6760	9000				
84	341	1.1	16.87	6020	7650	6600	9000				
93	308	1.1	15.20	5900	7650	6470	9000				
103	278	1.4	13.80	5780	7650	6310	9000				
113	254	1.5	12.59	5650	7650	6190	9000				
123	233	1.6	11.55	5540	7650	6040	9000				
133	215	1.7	10.64	5450	7650	5930	9000				
144	199	1.8	9.85	5340	7650	5820	9000				
156	184	1.8	9.12	5230	7650	5690	9000				
167	172	1.8	8.48	5150	7650	5590	9000				
180	159	1.8	7.90	5040	7650	5480	9000				
202	142	2.0	7.02	4930	7650	5350	9000				
226	127	2.3	6.27	4800	7650	5180	9000				
251	114	2.5	5.65	4660	7650	5040	9000				
277	103	2.6	5.13	4530	7650	4910	9000				
303	95	2.6	4.68	4410	7650	4770	9000				
331	87	2.6	4.29	4300	7580	4650	8820				
359	80	2.6	3.96	4200	7420	4540	8570				
388	74	2.6	3.66	4110	7220	4440	8380				
419	68	2.6	3.39	4020	7060	4350	8160				
451	64	2.6	3.15	3930	6870	4240	7920				
483	59	2.6	2.94	3850	6720	4160	7750	SK 25 - 100L/40	41	42 - 43	
91	315	1.0	15.35	1870	3540	5420	7340				
104	275	1.1	13.52	2490	3880	5560	7510				
116	247	1.2	12.03	2830	4090	5430	7570				
129	222	1.4	10.82	3130	4210	5320	7570				
145	198	1.5	9.77	3370	4340	5180	7500				
160	179	1.6	8.86	3590	4390	5060	7450				
176	163	1.6	8.09	3620	4430	4950	7360				
191	150	1.6	7.42	3570	4430	4850	7270				
208	138	1.6	6.82	3490	4400	4750	7140				
226	127	1.6	6.29	3430	4380	4650	7060				
244	117	1.6	5.82	3370	4380	4570	6920				
264	109	1.6	5.38	3310	4300	4470	6770				
284	101	1.6	5.00	3250	4250	4380	6650				
306	94	1.6	4.64	3190	4180	4290	6510				
323	89	1.6	4.33	3140	4120	4230	6390				
352	81	1.6	4.03	3070	4090	4130	6280				
376	76	1.6	3.75	3020	4000	4050	6140				
408	70	2.2	3.48	2990	4490	3990	6560				
442	65	2.2	3.21	2920	4380	3900	6390				
477	60	2.2	2.98	2860	4300	3810	6250				
516	56	2.2	2.75	2800	4210	3720	6070				
557	51	2.2	2.55	2740	4130	3640	5940				
599	48	2.2	2.37	2680	4020	3560	5770				

1) bei / at / pour F_A = 0 N

2) bei / at / pour F_Q = 0 N

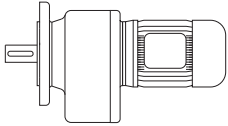

STIRNRADGETRIEBEMOTOREN HELICAL GEARED MOTORS MOTOREDUCTEURS A ENGRENAGES CYLINDRIQUES



DREHSTROM
THREE PHASE
A COURANT TRIPHASE

P _n [kW]	n ₂ [min ⁻¹]	M _a [Nm]	Standard f _B	i _{ges}	Normallagerung Normal bearing Roulement normal		Typenzusatz 5 Affix 5 Suffixe 5		Typ Type Type	ca. kg	Maße Dimens. Cotes
					F _{Q N} ¹⁾ [N]	F _{A N} ²⁾ [N]	F _Q ¹⁾ [N]	F _A ²⁾ [N]			
3.00	643	45	2.2	2.21	2630	3920	3490	5640	SK 25 - 100L/40	41	42 - 43
	689	42	2.2	2.06	2580	3840	3410	5480			
	729	39	2.2	1.92	2530	3780	3360	5410			
4.00	46	830	0.8	30.36	1870	5810	5220	11070	SK 33 V - 112M/4	62	42 - 43
	52	735	0.8	26.98	3030	6430	5960	11520			
	59	647	0.8	24.15	4090	7050	6590	11880			
	65	588	0.8	21.74	4680	7270	6890	12000			
	72	531	0.8	19.73	5180	7580	7130	12000			
	79	484	1.0	17.94	6810	9000	7570	12000	SK 33 - 112M/4	56	42 - 43
	94	406	1.2	15.60	6640	9000	7340	12000			
	106	360	1.4	13.73	6470	9000	7150	12000			
	119	321	1.5	12.20	6320	9000	6960	12000			
	133	287	1.7	10.92	6170	9000	6800	12000			
	148	258	1.9	9.83	6020	9000	6610	12000			
	167	229	1.8	8.67	5880	9000	6450	12000			
	188	203	2.1	7.70	5720	9000	6260	12000			
	210	182	2.3	6.90	5560	9000	6070	12000			
	233	164	2.6	6.21	5410	8840	5920	11770			
	258	148	2.6	5.63	5270	8640	5750	11410			
	283	135	2.6	5.12	5150	8400	5600	11090			
	309	124	2.6	4.69	5010	8210	5460	10760			
	338	113	2.6	4.29	4890	7960	5320	10470			
	368	104	2.6	3.94	4770	7750	5200	10200			
401	95	2.6	3.62	4660	7580	5070	9890				
75	509	0.8	18.85	3260	6120	4770	8300	SK 30 - 112M/4	48	42 - 43	
84	455	0.9	16.87	3890	6440	5250	8560				
93	411	0.8	15.20	4330	6640	5630	8660				
103	371	1.0	13.80	4710	6840	5900	8750				
113	338	1.1	12.59	4990	6910	5850	8820				
123	311	1.2	11.55	5210	6980	5740	8750				
133	287	1.3	10.64	5160	6980	5650	8730				
144	265	1.3	9.85	5080	6980	5560	8730				
156	245	1.3	9.12	4980	6980	5460	8590				
167	229	1.3	8.48	4910	6910	5370	8500				
180	212	1.3	7.90	4830	6850	5280	8410				
202	189	1.5	7.02	4750	7650	5190	9000				
226	169	1.7	6.27	4620	7500	5040	8920				
251	152	1.9	5.65	4510	7360	4890	8730				
277	138	2.0	5.13	4390	7200	4770	8520				
303	126	2.0	4.68	4290	7070	4660	8310				
331	115	2.0	4.29	4190	6920	4550	8130				
359	106	2.0	3.96	4100	6780	4440	7960				
388	98	2.0	3.66	4020	6640	4340	7760				
419	91	2.0	3.39	3940	6500	4260	7580				
451	85	2.0	3.15	3840	6340	4160	7420				
483	79	2.0	2.94	3780	6220	4090	7270				
104	367	0.8	13.52	-	-	2960	4890	SK 25 - 112M/4	46	42 - 43	
116	329	0.9	12.03	20	1760	3440	5140				
129	296	1.0	10.82	580	2110	3820	5360				
145	263	1.1	9.77	1140	2430	4230	5530				
160	239	1.2	8.86	1480	2610	4410	5590				
176	217	1.2	8.09	1810	2770	4620	5650				
191	200	1.2	7.42	2010	2890	4610	5650				
208	184	1.2	6.82	2180	2950	4520	5640				
226	169	1.2	6.29	2330	3040	4440	5640				
244	157	1.2	5.82	2440	3040	4360	5580				
264	145	1.2	5.38	2530	3070	4280	5530				
284	135	1.2	5.00	2600	3070	4210	5470				
306	125	1.2	4.64	2690	3100	4130	5410				
323	118	1.2	4.33	2690	3070	4080	5310				
352	109	1.2	4.03	2730	3040	3980	5210				
376	102	1.2	3.75	2740	3010	3910	5140				
408	94	1.7	3.48	2870	3730	3870	5810				
442	86	1.7	3.21	2820	3730	3800	5700				

1) bei / at / pour F_A = 0 N

2) bei / at / pour F_Q = 0 N



STIRNRADGETRIEBEMOTOREN HELICAL GEARED MOTORS MOTOREDUCTEURS A ENGRENAGES CYLINDRIQUES

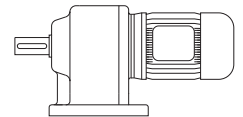

DREHSTROM
THREE PHASE
A COURANT TRIPHASE

P _n [kW]	n ₂ [min ⁻¹]	M _a [Nm]	Standard f _B	i _{ges}	Normallagerung Normal bearing Roulement normal		Typenzusatz 5 Affix 5 Suffixe 5		Typ Type Type	ca. kg	Maße Dimens. Cotes
					F _{Q N} ¹⁾ [N]	F _{A N} ²⁾ [N]	F _Q ¹⁾ [N]	F _A ²⁾ [N]			
4.00	477	80	1.7	2.98	2760	3650	3710	5580	SK 25 - 112M/4	46	42 - 43
	516	74	1.7	2.75	2710	3590	3630	5470			
	557	69	1.7	5.55	2650	3510	3560	5320			
	599	64	1.7	2.37	2600	3470	3490	5210			
	643	59	1.7	2.21	2550	3430	3420	5140			
	689	55	1.7	2.06	2510	3370	3350	5010			
	729	52	1.6	1.92	2470	3300	3290	4900			
5.50	94	559	0.9	15.60	4270	6240	6180	10300	SK 33 - 132S/4	69	42 - 43
	106	496	1.0	13.73	4880	6570	6520	10420			
	119	441	1.1	12.20	5370	6770	6490	10520			
	133	395	1.2	10.92	5710	6910	6370	10430			
	148	355	1.4	9.83	5630	6980	6240	10420			
	167	315	1.3	8.67	5530	7650	6140	10880			
	188	279	1.5	7.70	5410	7650	5960	10740			
	210	250	1.7	6.90	5280	7530	5820	10520			
	233	225	1.9	6.21	5160	7430	5670	10300			
	258	204	1.9	5.63	5040	7300	5530	10100			
	283	186	1.9	5.12	4920	7200	5400	9830			
	309	170	1.9	4.69	4830	7060	5290	9610			
	338	155	1.9	4.29	4710	6930	5160	9400			
	368	143	1.9	3.94	4610	6770	5040	9150			
	401	131	1.9	3.62	4510	6630	4940	8940			
	433	121	1.9	3.35	4420	6510	4840	8720			
	453	116	2.2	3.20	4390	6800	4790	9030			
	495	106	2.2	2.93	4280	6630	4670	8760			
	541	97	2.2	2.68	4170	6460	4550	8500			
589	89	2.2	2.46	4090	6310	4440	8250				
642	82	2.2	2.26	3980	6120	4330	8010				
694	76	2.2	2.09	3890	5960	4240	7790				
7.50	119	602	0.8	12.20	1070	3360	3590	6860	SK 33 - 132M/4	80	42 - 43
	133	539	0.9	10.92	1850	3790	4080	7140			
	148	484	1.0	9.83	2530	4120	4440	7370			
	167	429	1.0	8.67	4090	5260	5570	8410			
	188	381	1.1	7.70	4530	5420	5580	8430			
	210	341	1.2	6.90	4860	5530	5460	8440			
	233	307	1.4	6.21	4830	5640	5350	8410			
	258	278	1.4	5.63	4730	5640	5230	8320			
	283	253	1.4	5.12	4650	5640	5140	8240			
	309	232	1.4	4.69	4560	5590	5040	8080			
	338	212	1.4	4.29	4480	5550	4930	7990			
	368	195	1.4	3.94	4400	5480	4830	7830			
	401	179	1.4	3.62	4300	5420	4730	7680			
	433	165	1.4	3.35	4230	5360	4640	7530			
	453	158	1.6	3.20	4220	5870	4620	7990			
	495	145	1.6	2.93	4120	5720	4520	7830			
	541	132	1.6	2.68	4030	5640	4410	7640			
	589	122	1.6	2.46	3940	5490	4320	7450			
	642	112	1.6	2.26	3850	5370	4210	7250			
694	103	1.6	2.09	3780	5270	4120	7090				

1) bei / at / pour F_A = 0 N

2) bei / at / pour F_Q = 0 N

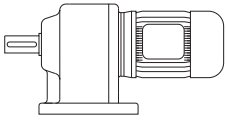

STIRNRADGETRIEBEMOTOREN HELICAL GEARED MOTORS MOTOREDUCTEURS A ENGRENAGES CYLINDRIQUES



DREHSTROM, POLUMSCHALTBAR 1:2
THREE PHASE, POLE CHANGING 1:2
A COURANT TRIPHASE, A POLES COMMUTABLES 1:2

P _n [kW]	n ₂ [min ⁻¹]	M _a [Nm]	Standard f _B	i _{ges}	Normallagerung Normal bearing Roulement normal		Typenzusatz 5 Affix 5 Suffixe 5		Typ Type Type	ca. kg	Maße Dimens. Cotes			
					F _{Q N} ¹⁾ [N]	F _{A N} ²⁾ [N]	F _Q ¹⁾ [N]	F _A ²⁾ [N]						
0.10 / 0.15	2.90/ 5.90	329/ 243	1.2/ 1.6	484.62	7150	7650	11270	9000	SK 300 - 63S/4-2	32	44 - 45			
	3.30/ 6.60	289/ 217	1.4/ 1.8	429.23	7260	7650	11330	9000						
	3.70/ 7.40	258/ 194	1.5/ 2.1	383.92	7340	7650	11380	9000						
	3.80/ 7.60	251/ 188	1.3/ 1.8	376.15	7360	7650	11390	9000						
	4.50/ 9.00	212/ 159	1.9/ 2.5	314.20	7440	7650	11430	9000						
	4.90/ 9.90	195/ 145	2.0/ 2.7	286.81	7480	7650	11450	9000						
	2.90/ 5.80	329/ 247	0.8/ 1.0	488.07	4190	5600	7150	7650	SK 250 - 63S/4-2	21	44 - 45			
	3.30/ 6.70	289/ 214	1.0/ 1.4	425.34	4380	5600	7260	7650						
	3.80/ 7.60	251/ 188	1.2/ 1.6	374.85	4540	5600	7360	7650						
	4.00/ 7.90	239/ 181	1.1/ 1.4	357.73	4590	5600	7390	7650						
	4.20/ 8.50	227/ 169	1.3/ 1.8	333.54	4630	5600	7410	7650						
	4.50/ 9.10	212/ 157	1.4/ 1.9	311.75	4680	5600	7440	7650						
	5.20/10.00	184/ 143	1.6/ 2.1	274.74	4760	5600	7500	7650						
	5.80/12.00	165/ 119	1.8/ 2.5	244.47	4810	5600	7530	7650						
	6.40/13.00	149/ 110	2.0/ 2.7	219.79	4840	5600	7550	7650						
	7.10/14.00	135/ 102	2.2/ 2.9	198.49	4870	5600	7570	7650						
	3.30/ 6.60	250/ 217	0.8/ 0.9	433.50	2780	3900	5340	5600	SK 200 - 63S/4-2	23	44 - 45			
	4.00/ 8.10	239/ 177	0.8/ 1.1	350.20	2870	3900	5380	5600						
	4.60/ 9.30	208/ 154	1.0/ 1.3	304.80	3090	3900	5470	5600						
	5.30/11.00	180/ 130	1.1/ 1.5	268.49	3250	3900	5550	5600						
	5.90/12.00	162/ 119	1.2/ 1.7	238.77	3340	3900	5590	5600						
	6.60/13.00	145/ 110	1.4/ 1.8	214.01	3410	3900	5620	5600						
	7.30/15.00	131/ 96	1.5/ 2.1	193.06	3460	3900	5650	5600						
	8.10/16.00	118/ 90	1.7/ 2.2	175.10	3510	3900	5670	5600						
	8.90/18.00	107/ 80	1.7/ 2.3	159.54	3540	3900	5690	5600						
	9.70/19.00	98/ 75	1.7/ 2.2	145.92	3560	3900	5700	5600						
	11/ 21	87/ 68	1.8/ 2.2	133.90	3590	3900	5710	5600						
	11/ 23	87/ 62	1.6/ 2.3	123.22	3590	3900	5710	5600						
	12/ 25	80/ 57	1.6/ 2.3	113.66	3600	3900	5720	5600						
	14/ 27	68/ 53	2.9/ 3.8	104.17	3630	3900	5730	5600						
	6.40/13.00	125/ 110	0.8/ 0.9	221.00	1800	2500	3480	3900				SK 010 - 63S/4-2	16	44 - 45
	7.20/14.00	133/ 102	0.8/ 1.0	196.89	1700	2500	3450	3900						
	8.00/16.00	119/ 90	0.8/ 1.1	176.80	1860	2500	3500	3900						
	8.90/18.00	107/ 80	0.9/ 1.3	159.80	1980	2500	3540	3900						
	9.70/20.00	98/ 72	1.0/ 1.4	145.23	2050	2500	3560	3900						
	11/ 21	87/ 68	1.2/ 1.5	132.60	2130	2500	3590	3900						
	12/ 23	80/ 62	1.3/ 1.6	121.55	2170	2500	3600	3900						
	13/ 25	73/ 57	1.3/ 1.6	111.61	2210	2500	3620	3900	SK 01 - 63S/4-2	13	42 - 43			
	15/ 29	64/ 49	1.6/ 2.0	97.35	2260	2500	3630	3900						
	16/ 33	60/ 43	1.5/ 2.1	85.85	2280	2500	3640	3900						
	19/ 37	50/ 39	1.9/ 2.4	76.12	2310	2500	3660	3900						
	21/ 43	45/ 33	2.2/ 3.0	66.40	2330	2500	3660	3900						
	24/ 49	40/ 29	2.3/ 3.2	58.50	2350	2500	3670	3900						
	28/ 56	34/ 26	2.9/ 3.9	51.03	2360	2500	3580	3900						
	31/ 63	31/ 23	3.2/> 4.0	45.00	2370	2500	3460	3900						
	35/ 71	27/ 20	3.7/> 4.0	40.05	2370	2500	3330	3900						
	39/ 79	24/ 18	> 4.0/> 4.0	36.00	2380	2500	3230	3900						
	43/ 87	22/ 16	> 4.0/> 4.0	32.58	2380	2500	3130	3900						
	48/ 96	20/ 15	> 4.0/> 4.0	29.61	2390	2500	3030	3900						
	52/ 105	18/ 14	> 4.0/> 4.0	27.00	2350	2500	2950	3900						
	57/ 115	17/ 12	> 4.0/> 4.0	24.75	2290	2500	2860	3900						
	62/ 125	15/ 11	> 4.0/> 4.0	22.77	2240	2500	2790	3900						
	67/ 135	14/ 11	> 4.0/> 4.0	20.97	2180	2500	2720	3900						
	73/ 146	13/ 10	> 4.0/> 4.0	19.44	2120	2500	2650	3900						
	79/ 158	12/ 9	> 4.0/> 4.0	18.00	2070	2500	2580	3900						
	84/ 168	11/ 9	> 4.0/> 4.0	16.90	2040	2500	2540	3900						
	85/ 170	11/ 8	> 4.0/> 4.0	16.74	2020	2500	2520	3900						
	91/ 182	10/ 8	> 4.0/> 4.0	15.57	1980	2500	2470	3900						
	96/ 193	10/ 7	> 4.0/> 4.0	14.74	1950	2500	2420	3900						
	109/ 218	9/ 7	> 4.0/> 4.0	13.00	1870	2500	2330	3900						
	122/ 245	8/ 6	> 4.0/> 4.0	11.57	1800	2500	2240	3900						
	136/ 273	7/ 5	> 4.0/> 4.0	10.40	1740	2500	2170	3900						
	150/ 302	6/ 5	> 4.0/> 4.0	9.41	1680	2500	2090	3900						
	165/ 332	6/ 4	> 4.0/> 4.0	8.55	1630	2500	2030	3900						
	181/ 364	5/ 4	> 4.0/> 4.0	7.80	1590	2500	1970	3900						

1) bei / at / pour F_A = 0 N

2) bei / at / pour F_Q = 0 N



STIRNRADGETRIEBEMOTOREN HELICAL GEARED MOTORS MOTOREDUCTEURS A ENGRENAGES CYLINDRIQUES

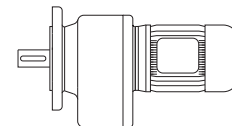

DREHSTROM, POLUMSCHALTBAR 1:2
THREE PHASE, POLE CHANGING 1:2
A COURANT TRIPHASE, A POLES COMMUTABLES 1:2

P _n [kW]	n ₂ [min ⁻¹]	M _a [Nm]	Standard f _B	i _{ges}	Normallagerung Normal bearing Roulement normal		Typenzusatz 5 Affix 5 Suffixe 5		Typ Type Type	ca. kg	Maße Dimens. Cotes			
					F _{QN} ¹⁾ [N]	F _{AN} ²⁾ [N]	F _Q ¹⁾ [N]	F _A ²⁾ [N]						
0.10 / 0.15	198/ 397	5/ 4	> 4.0/> 4.0	7.15	1540	2500	1920	3900	SK 01 - 63S/4-2	13	42 - 43			
	215/ 432	4/ 3	> 4.0/> 4.0	6.58	1500	2500	1870	3900						
	233/ 469	4/ 3	> 4.0/> 4.0	6.06	1460	2500	1810	3900						
	252/ 505	4/ 3	> 4.0/> 4.0	5.62	1430	2500	1770	3900						
	272/ 546	4/ 3	> 4.0/> 4.0	5.20	1390	2500	1720	3900						
	292/ 587	3/ 2	> 4.0/> 4.0	4.84	1360	2500	1690	3900						
	20/ 40	48/ 36	1.0/ 1.4	70.98	1090	1620	2640	2500				SK 0 - 63S/4-2	10	42 - 43
	23/ 46	42/ 31	1.2/ 1.6	61.96	1130	1620	2660	2500						
	26/ 52	37/ 28	1.4/ 1.8	54.46	1160	1620	2670	2500						
	30/ 60	32/ 24	1.6/ 2.1	47.54	1180	1620	2690	2500						
	34/ 68	28/ 21	1.8/ 2.4	42.01	1200	1620	2690	2500						
	42/ 84	23/ 17	2.2/ 2.9	33.69	1220	1620	2700	2500						
	46/ 93	21/ 15	2.4/ 3.2	30.50	1230	1620	2710	2500						
	51/ 102	19/ 14	2.7/ 3.6	27.77	1230	1620	2710	2500						
	61/ 122	16/ 12	3.2/> 4.0	23.34	1240	1620	2670	2500						
71/ 143	13/ 10	3.3/> 4.0	19.92	1250	1620	2540	2500							
83/ 166	12/ 9	3.3/> 4.0	17.12	1230	1620	2420	2500							
94/ 188	10/ 8	> 4.0/> 4.0	15.12	1180	1620	2330	2500							
107/ 215	9/ 7	> 4.0/> 4.0	13.20	1130	1620	2230	2500							
121/ 244	8/ 6	> 4.0/> 4.0	11.66	1090	1620	2140	2500							
151/ 304	6/ 5	> 4.0/> 4.0	9.35	1020	1620	2000	2500							
167/ 335	6/ 4	> 4.0/> 4.0	8.47	990	1620	1930	2500							
184/ 368	5/ 4	> 4.0/> 4.0	7.71	960	1620	1880	2500							
218/ 438	4/ 3	> 4.0/> 4.0	6.48	900	1620	1770	2500							
256/ 514	4/ 3	> 4.0/> 4.0	5.53	860	1620	1680	2500							
0.15 / 0.19	2.90/ 5.90	494/ 308	0.8/ 1.3	484.62	6460	7650	10910	9000	SK 300 - 63L/4-2	32	44 - 45			
	3.30/ 6.60	434/ 275	0.9/ 1.5	429.23	6750	7650	11060	9000						
	3.60/ 7.40	398/ 245	1.0/ 1.6	383.92	6900	7650	11140	9000						
	3.70/ 7.60	387/ 239	0.9/ 1.4	376.15	6940	7650	11160	9000						
	4.50/ 9.10	318/ 199	1.3/ 2.0	314.20	7180	7650	11290	9000						
	4.90/ 9.90	292/ 183	1.4/ 2.2	286.81	7260	7650	11330	9000						
	5.30/11.00	270/ 165	1.5/ 2.4	263.08	7310	7650	11360	9000						
	5.80/12.00	247/ 151	1.6/ 2.6	242.31	7370	7650	11390	9000						
	6.30/13.00	227/ 140	1.8/ 2.9	223.98	7410	7650	11420	9000						
	6.70/14.00	214/ 130	1.8/ 3.0	207.69	7440	7650	11430	9000						
	3.70/ 7.60	387/ 239	0.8/ 1.3	374.85	3830	5600	6940	7650				SK 250 - 63L/4-2	21	44 - 45
	4.20/ 8.50	341/ 213	0.9/ 1.4	333.54	4120	5600	7110	7650						
	4.50/ 9.10	318/ 199	0.9/ 1.5	311.75	4240	5600	7180	7650						
	5.10/10.00	281/ 181	1.1/ 1.7	274.74	4420	5600	7290	7650						
	5.70/12.00	251/ 151	1.2/ 2.0	244.47	4540	5600	7360	7650						
6.40/13.00	224/ 140	1.3/ 2.1	219.79	4640	5600	7420	7650							
7.10/14.00	202/ 130	1.5/ 2.3	198.49	4710	5600	7460	7650							
7.80/16.00	184/ 113	1.6/ 2.6	179.98	4760	5600	7500	7650							
8.50/17.00	169/ 107	1.8/ 2.8	164.29	4800	5600	7520	7650							
9.30/19.00	154/ 96	1.8/ 2.9	150.83	4830	5600	7540	7650							
10/ 21	143/ 86	1.8/ 3.0	138.49	4850	5600	7560	7650							
11/ 22	130/ 82	1.8/ 2.9	127.84	4880	5600	7570	7650							
11/ 23	130/ 79	2.4/ 4.0	122.88	4880	5600	7570	7650							
5.90/12.00	243/ 151	0.8/ 1.3	238.77	2840	3900	5360	5600	SK 200 - 63L/4-2	23	44 - 45				
6.50/13.00	220/ 140	0.9/ 1.4	214.01	3010	3900	5440	5600							
7.30/15.00	196/ 121	1.0/ 1.7	193.06	3160	3900	5510	5600							
8.00/16.00	179/ 113	1.1/ 1.8	175.10	3250	3900	5550	5600							
8.80/18.00	163/ 101	1.1/ 1.8	159.54	3330	3900	5590	5600							
9.60/20.00	149/ 91	1.1/ 1.8	145.92	3390	3900	5610	5600							
10/ 21	143/ 86	1.1/ 1.8	133.90	3420	3900	5630	5600							
11/ 23	130/ 79	1.1/ 1.8	123.22	3470	3900	5650	5600							
12/ 25	119/ 73	1.1/ 1.8	113.66	3500	3900	5670	5600							
13/ 27	110/ 67	1.8/ 3.0	104.17	3530	3900	5680	5600							
15/ 31	96/ 59	2.1/ 3.4	91.75	3570	3900	5700	5600							
17/ 35	84/ 52	2.4/ 3.9	81.60	3600	3900	5710	5600							
18/ 37	80/ 49	2.5/> 4.0	76.50	3600	3900	5720	5600				SK 20 - 63L/4-2	16	42 - 43	
11/ 21	130/ 86	0.8/ 1.2	132.60	1740	2500	3470	3900				SK 010 - 63L/4-2	16	44 - 45	

1) bei / at / pour F_A = 0 N

2) bei / at / pour F_Q = 0 N

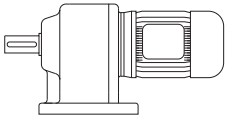

STIRNRADGETRIEBEMOTOREN HELICAL GEARED MOTORS MOTOREDUCTEURS A ENGRENAGES CYLINDRIQUES



DREHSTROM, POLUMSCHALTBAR 1:2
THREE PHASE, POLE CHANGING 1:2
A COURANT TRIPHASE, A POLES COMMUTABLES 1:2

P _n [kW]	n ₂ [min ⁻¹]	M _a [Nm]	Standard f _B	i _{ges}	Normallagerung Normal bearing Roulement normal		Typenzusatz 5 Affix 5 Suffixe 5		Typ Type Type	ca. kg	Maße Dimens. Cotes
					F _{Q N} ¹⁾ [N]	F _{A N} ²⁾ [N]	F _Q ¹⁾ [N]	F _A ²⁾ [N]			
0.15 / 0.19	12/ 23	119/ 79	0.8/ 1.3	121.55	1860	2500	3500	3900	SK 010 - 63L/4-2	16	44 - 45
	13/ 25	110/ 73	0.9/ 1.4	111.80	1950	2500	3530	3900			
	14/ 28	102/ 65	0.9/ 1.5	103.13	2020	2500	3550	3900			
	15/ 30	96/ 60	0.9/ 1.5	95.38	2070	2500	3570	3900			
	16/ 32	90/ 57	0.9/ 1.4	88.40	2110	2500	3580	3900			
	17/ 34	84/ 53	1.2/ 1.9	83.49	2150	2500	3600	3900			
	13/ 26	110/ 70	0.8/ 1.3	111.61	1950	2500	3530	3900			
	14/ 29	102/ 63	1.0/ 1.6	97.35	2020	2500	3550	3900			
	16/ 33	90/ 55	1.0/ 1.6	85.85	2110	2500	3580	3900			
	18/ 37	80/ 49	1.2/ 1.9	76.12	2170	2500	3600	3900			
	21/ 43	68/ 42	1.5/ 2.4	66.40	2240	2500	3630	3900			
	24/ 49	60/ 37	1.6/ 2.5	58.50	2280	2500	3640	3900			
	27/ 56	53/ 32	1.9/ 3.1	51.03	2300	2500	3550	3900			
	31/ 63	46/ 29	2.2/ 3.5	45.00	2330	2500	3430	3900			
	35/ 71	41/ 26	2.4/ 3.9	40.05	2340	2500	3300	3900			
	39/ 79	37/ 23	2.7/ > 4.0	36.00	2350	2500	3200	3900			
	43/ 87	33/ 21	2.8/ > 4.0	32.58	2360	2500	3100	3900			
47/ 96	30/ 19	2.8/ > 4.0	29.61	2370	2500	3010	3900				
52/ 106	28/ 17	2.8/ > 4.0	27.00	2330	2500	2920	3900				
57/ 115	25/ 16	2.8/ > 4.0	24.75	2270	2500	2840	3900				
61/ 125	23/ 15	2.8/ > 4.0	22.77	2210	2500	2760	3900				
67/ 136	21/ 13	2.8/ > 4.0	20.97	2160	2500	2690	3900				
72/ 147	20/ 12	2.8/ > 4.0	19.44	2110	2500	2630	3900				
78/ 158	18/ 11	2.8/ > 4.0	18.00	2060	2500	2570	3900				
83/ 169	17/ 11	> 4.0/ > 4.0	16.90	2020	2500	2520	3900				
84/ 170	17/ 11	2.8/ > 4.0	16.74	2010	2500	2510	3900				
90/ 183	16/ 10	2.8/ > 4.0	15.57	1960	2500	2460	3900				
95/ 193	15/ 9	> 4.0/ > 4.0	14.74	1940	2500	2420	3900				
108/ 219	13/ 8	> 4.0/ > 4.0	13.00	1860	2500	2320	3900				
121/ 246	12/ 7	> 4.0/ > 4.0	11.57	1790	2500	2230	3900				
135/ 274	11/ 7	> 4.0/ > 4.0	10.40	1730	2500	2160	3900				
149/ 303	10/ 6	> 4.0/ > 4.0	9.41	1680	2500	2090	3900				
164/ 333	9/ 5	> 4.0/ > 4.0	8.55	1630	2500	2030	3900				
179/ 365	8/ 5	> 4.0/ > 4.0	7.80	1580	2500	1960	3900				
196/ 399	7/ 5	> 4.0/ > 4.0	7.15	1530	2500	1910	3900				
213/ 433	7/ 4	> 4.0/ > 4.0	6.58	1490	2500	1860	3900				
231/ 470	6/ 4	> 4.0/ > 4.0	6.06	1460	2500	1810	3900				
249/ 507	6/ 4	> 4.0/ > 4.0	5.62	1420	2500	1760	3900				
269/ 548	5/ 3	> 4.0/ > 4.0	5.20	1380	2500	1720	3900				
289/ 589	5/ 3	> 4.0/ > 4.0	4.84	1350	2500	1680	3900				
23/ 46	62/ 39	0.8/ 1.3	61.96	950	1620	2590	2500				
26/ 52	55/ 35	0.9/ 1.4	54.46	1030	1620	2620	2500				
29/ 60	49/ 30	1.0/ 1.7	47.54	1080	1620	2640	2500				
33/ 68	43/ 27	1.2/ 1.9	42.01	1120	1620	2660	2500				
42/ 85	34/ 21	1.5/ 2.3	33.69	1170	1620	2680	2500				
46/ 93	31/ 20	1.6/ 2.6	30.50	1190	1620	2690	2500				
50/ 103	29/ 18	1.7/ 2.8	27.77	1200	1620	2690	2500				
60/ 122	24/ 15	2.1/ 3.4	23.34	1220	1620	2650	2500				
70/ 143	20/ 13	2.2/ 3.5	19.92	1230	1620	2520	2500				
82/ 166	17/ 11	2.2/ 3.5	17.12	1210	1620	2400	2500				
93/ 188	15/ 10	3.2/ > 4.0	15.12	1170	1620	2320	2500				
106/ 216	14/ 8	3.7/ > 4.0	13.20	1120	1620	2220	2500				
120/ 244	12/ 7	> 4.0/ > 4.0	11.66	1080	1620	2140	2500				
150/ 305	10/ 6	> 4.0/ > 4.0	9.35	1010	1620	1990	2500				
165/ 336	9/ 5	> 4.0/ > 4.0	8.47	980	1620	1920	2500				
182/ 370	8/ 5	> 4.0/ > 4.0	7.71	950	1620	1870	2500				
216/ 440	7/ 4	> 4.0/ > 4.0	6.48	900	1620	1770	2500				
253/ 515	6/ 4	> 4.0/ > 4.0	5.53	850	1620	1680	2500				
295/ 600	5/ 3	> 4.0/ > 4.0	4.75	810	1620	1590	2500				
0.21 / 0.28	4.50/ 8.80	446/ 304	0.9/ 1.3	314.20	6690	7650	11030	9000	SK 300 - 71S/4-2	33	44 - 45
	4.90/ 9.70	409/ 276	1.0/ 1.4	286.81	6860	7650	11110	9000			
	5.40/ 11.00	371/ 243	1.1/ 1.6	263.08	7000	7650	11190	9000			
	5.80/ 11.00	346/ 243	1.2/ 1.6	242.31	7090	7650	11240	9000			
	6.30/ 12.00	318/ 223	1.3/ 1.8	223.98	7180	7650	11290	9000			
	6.80/ 13.00	295/ 206	1.3/ 1.9	207.69	7250	7650	11320	9000			

1) bei / at / pour F_A = 0 N

2) bei / at / pour F_Q = 0 N



STIRNRADGETRIEBEMOTOREN HELICAL GEARED MOTORS MOTOREDUCTEURS A ENGRENAGES CYLINDRIQUES

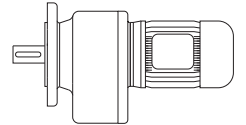

DREHSTROM, POLUMSCHALTBAR 1:2
THREE PHASE, POLE CHANGING 1:2
A COURANT TRIPHASE, A POLES COMMUTABLES 1:2

P _n [kW]	n ₂ [min ⁻¹]	M _a [Nm]	Standard f _B	i _{ges}	Normallagerung Normal bearing Roulement normal		Typenzusatz 5 Affix 5 Suffixe 5		Typ Type Type	ca. kg	Maße Dimens. Cotes				
					F _{Q N} ¹⁾ [N]	F _{A N} ²⁾ [N]	F _Q ¹⁾ [N]	F _A ²⁾ [N]							
0.21 / 0.28	7.30/14.00	275/ 191	1.3/ 1.9	193.12	7300	7650	11350	9000	SK 300 - 71S/4-2	33	44 - 45				
	7.80/15.00	257/ 178	1.3/ 1.9	180.00	7350	7650	11380	9000							
	8.30/16.00	242/ 167	1.7/ 2.4	169.39	7380	7650	11400	9000							
	9.30/18.00	216/ 149	1.9/ 2.7	151.51	7440	7650	11430	9000							
	10/ 20	201/ 134	1.7/ 2.5	136.61	7470	7650	11440	9000							
	5.10/10.00	393/ 267	0.8/ 1.1	274.74	3790	5600	6920	7650	SK 250 - 71S/4-2	22	44 - 45				
	5.80/11.00	346/ 243	0.9/ 1.2	244.47	4090	5600	7090	7650							
	6.40/13.00	313/ 206	1.0/ 1.5	219.79	4270	5600	7190	7650							
	7.10/14.00	282/ 191	1.1/ 1.6	198.49	4420	5600	7280	7650							
	7.80/15.00	257/ 178	1.2/ 1.7	179.98	4520	5600	7350	7650							
	8.60/17.00	233/ 157	1.3/ 1.9	164.29	4610	5600	7400	7650							
	9.30/18.00	216/ 149	1.3/ 1.9	150.83	4670	5600	7440	7650							
	10/ 20	201/ 134	1.3/ 1.9	138.49	4710	5600	7470	7650							
	11/ 22	182/ 122	1.3/ 2.0	127.84	4760	5600	7500	7650							
	11/ 23	182/ 116	1.7/ 2.7	122.88	4760	5600	7500	7650							
	13/ 26	154/ 103	1.9/ 2.9	108.29	4830	5600	7540	7650							
		8.10/16.00	248/ 167	0.8/ 1.2	175.10	2800	3900	5350				5600	SK 200 - 71S/4-2	24	44 - 45
		8.80/17.00	228/ 157	0.8/ 1.2	159.54	2950	3900	5410				5600			
9.70/19.00		207/ 141	0.8/ 1.2	145.92	3090	3900	5480	5600							
11/ 21		182/ 127	0.8/ 1.2	133.90	3240	3900	5540	5600							
11/ 23		182/ 116	0.8/ 1.2	123.22	3240	3900	5540	5600							
12/ 24		167/ 111	0.8/ 1.2	113.66	3310	3900	5580	5600							
14/ 27		143/ 99	1.4/ 2.0	104.17	3420	3900	5630	5600							
15/ 30		134/ 89	1.5/ 2.2	91.75	3450	3900	5640	5600							
17/ 34		118/ 79	1.7/ 2.5	81.60	3510	3900	5670	5600							
		18/ 36	111/ 74	1.8/ 2.7	76.50	3530	3900	5680	5600	SK 20 - 71S/4-2	17	42 - 43			
	21/ 42	96/ 64	2.1/ 3.1	66.56	3570	3900	5700	5600							
	23/ 45	87/ 59	2.3/ 3.4	61.80	3590	3900	5690	5600							
	24/ 47	84/ 57	2.3/ 3.4	58.65	3600	3900	5610	5600							
	26/ 52	77/ 51	2.6/ 3.9	53.77	3610	3900	5470	5600							
	30/ 59	67/ 45	3.0/> 4.0	47.38	3630	3900	5250	5600							
		17/ 33	118/ 81	0.8/ 1.2	83.49	1870	2500	3510	3900				SK 010 - 71S/4-2	17	44 - 45
19/ 38		106/ 70	0.9/ 1.4	73.67	1990	2500	3540	3900							
21/ 42		96/ 64	1.0/ 1.6	65.63	2070	2500	3570	3900							
	24/ 48	84/ 56	1.1/ 1.7	58.50	2150	2500	3600	3900	SK 01 - 71S/4-2	14	42 - 43				
	28/ 54	72/ 50	1.4/ 2.0	51.03	2220	2500	3500	3900							
	31/ 62	65/ 43	1.5/ 2.3	45.00	2250	2500	3370	3900							
	35/ 69	57/ 39	1.7/ 2.6	40.05	2290	2500	3260	3900							
	39/ 77	51/ 35	1.9/ 2.9	36.00	2310	2500	3160	3900							
	43/ 85	47/ 31	2.0/ 3.0	32.58	2320	2500	3070	3900							
	48/ 94	42/ 28	2.0/ 3.0	29.61	2340	2500	2980	3900							
	52/ 103	39/ 26	2.0/ 3.0	27.00	2300	2500	2900	3900							
	57/ 112	35/ 24	2.0/ 2.9	24.75	2240	2500	2820	3900							
	62/ 122	32/ 22	2.0/ 3.0	22.77	2190	2500	2750	3900							
	67/ 133	30/ 20	2.0/ 3.0	20.97	2140	2500	2670	3900							
	73/ 143	27/ 19	2.0/ 2.9	19.44	2080	2500	2620	3900							
	78/ 154	26/ 17	2.0/ 2.9	18.00	2040	2500	2560	3900							
	83/ 164	24/ 16	3.8/> 4.0	16.90	2010	2500	2520	3900							
	84/ 166	24/ 16	2.0/ 3.0	16.74	1990	2500	2500	3900							
	91/ 179	22/ 15	2.0/ 2.9	15.57	1940	2500	2440	3900							
	96/ 189	21/ 14	> 4.0/> 4.0	14.74	1920	2500	2410	3900							
	108/ 214	19/ 12	> 4.0/> 4.0	13.00	1860	2500	2320	3900							
	122/ 240	16/ 11	> 4.0/> 4.0	11.57	1790	2500	2230	3900							
	136/ 267	15/ 10	> 4.0/> 4.0	10.40	1730	2500	2160	3900							
	150/ 295	13/ 9	> 4.0/> 4.0	9.41	1670	2500	2090	3900							
	165/ 325	12/ 8	> 4.0/> 4.0	8.55	1620	2500	2020	3900							
	181/ 356	11/ 8	> 4.0/> 4.0	7.80	1580	2500	1970	3900							
	197/ 389	10/ 7	> 4.0/> 4.0	7.15	1530	2500	1910	3900							
	214/ 422	9/ 6	> 4.0/> 4.0	6.58	1490	2500	1870	3900							
	233/ 459	9/ 6	> 4.0/> 4.0	6.06	1460	2500	1810	3900							
	251/ 495	8/ 5	> 4.0/> 4.0	5.62	1420	2500	1770	3900							
	271/ 535	7/ 5	> 4.0/> 4.0	5.20	1380	2500	1720	3900							
	291/ 574	7/ 5	> 4.0/> 4.0	4.84	1350	2500	1690	3900							
	313/ 618	6/ 4	> 4.0/> 4.0	4.50	1320	2500	1640	3900							

1) bei / at / pour F_A = 0 N

2) bei / at / pour F_Q = 0 N

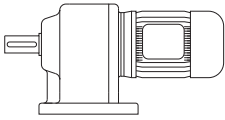

STIRNRADGETRIEBEMOTOREN HELICAL GEARED MOTORS MOTOREDUCTEURS A ENGRENAGES CYLINDRIQUES



DREHSTROM, POLUMSCHALTBAR 1:2
THREE PHASE, POLE CHANGING 1:2
A COURANT TRIPHASE, A POLES COMMUTABLES 1:2

P _n [kW]	n ₂ [min ⁻¹]	M _a [Nm]	Standard f _B	i _{ges}	Normallagerung Normal bearing Roulement normal		Typenzusatz 5 Affix 5 Suffixe 5		Typ Type Type	ca. kg	Maße Dimens. Cotes			
					F _{Q N} ¹⁾ [N]	F _{A N} ²⁾ [N]	F _Q ¹⁾ [N]	F _A ²⁾ [N]						
0.21 / 0.28	327/ 645	6/ 4	> 4.0/> 4.0	4.31	1300	2500	1620	3900	SK 01 - 71S/4-2	14	42 - 43			
	34/ 66	59/ 41	0.8/ 1.2	42.01	990	1620	2600	2500	SK 0 - 71S/4-2	11	42 - 43			
	42/ 83	48/ 32	1.0/ 1.6	33.69	1090	1620	2640	2500						
	46/ 91	44/ 29	1.1/ 1.7	30.50	1120	1620	2650	2500						
	51/ 100	39/ 27	1.3/ 1.9	27.77	1150	1620	2670	2500						
	60/ 119	33/ 22	1.5/ 2.2	23.34	1180	1620	2630	2500						
	71/ 140	28/ 19	1.6/ 2.4	19.92	1200	1620	2500	2500						
	82/ 162	24/ 17	1.6/ 2.3	17.12	1180	1620	2380	2500						
	93/ 184	22/ 15	2.3/ 3.4	15.12	1150	1620	2310	2500						
	107/ 211	19/ 13	2.7/ 3.9	13.20	1100	1620	2210	2500						
	121/ 238	17/ 11	3.0/> 4.0	11.66	1070	1620	2130	2500						
	151/ 297	13/ 9	3.8/> 4.0	9.35	1000	1620	1990	2500						
	166/ 328	12/ 8	> 4.0/> 4.0	8.47	970	1620	1920	2500						
	183/ 361	11/ 7	> 4.0/> 4.0	7.71	940	1620	1870	2500						
	218/ 429	9/ 6	> 4.0/> 4.0	6.48	890	1620	1770	2500						
	255/ 503	8/ 5	> 4.0/> 4.0	5.53	850	1620	1680	2500						
297/ 585	7/ 5	> 4.0/> 4.0	4.75	810	1610	1600	2500							
0.30 / 0.45	5.70/11.00	503/ 391	0.8/ 1.0	242.31	6410	7650	10880	9000	SK 300 - 71L/4-2	34	44 - 45			
	6.20/12.00	462/ 358	0.9/ 1.1	223.98	6620	7650	10990	9000						
	6.70/13.00	428/ 331	0.9/ 1.2	207.69	6770	7650	11070	9000						
	7.20/14.00	398/ 307	0.9/ 1.2	193.12	6900	7650	11140	9000						
	7.70/15.00	372/ 286	0.9/ 1.2	180.00	7000	7650	11190	9000						
	8.20/16.00	349/ 269	1.1/ 1.5	169.39	7080	7650	11230	9000						
	9.10/18.00	315/ 239	1.3/ 1.7	151.51	7190	7650	11290	9000						
	10/ 20	286/ 215	1.2/ 1.6	136.61	7270	7650	11340	9000						
	11/ 22	260/ 195	1.5/ 2.0	124.00	7340	7650	11370	9000						
	12/ 24	239/ 179	1.7/ 2.2	110.91	7390	7650	11280	9000						
	7.70/15.00	372/ 286	0.8/ 1.0	179.98	3930	5600	7000	7650				SK 250 - 71L/4-2	23	44 - 45
	8.40/17.00	341/ 253	0.9/ 1.2	164.29	4120	5600	7110	7650						
	9.20/18.00	311/ 239	0.9/ 1.2	150.83	4280	5600	7200	7650						
10/ 20	286/ 215	0.9/ 1.2	138.49	4400	5600	7270	7650							
11/ 21	260/ 205	0.9/ 1.2	127.84	4510	5600	7340	7650							
11/ 22	260/ 195	1.2/ 1.6	122.88	4510	5600	7340	7650							
13/ 25	220/ 172	1.4/ 1.7	108.29	4650	5600	7430	7650							
14/ 28	205/ 153	1.5/ 2.0	96.36	4700	5600	7460	7650							
15/ 30	191/ 143	1.6/ 2.1	90.06	4740	5600	7480	7650							
17/ 34	169/ 126	1.8/ 2.4	79.37	4800	5600	7520	7650							
20/ 38	143/ 113	2.1/ 2.7	70.62	4850	5600	7560	7650							
13/ 26	220/ 165	0.9/ 1.2	104.17	3010	3900	5440	5600	SK 200 - 71L/4-2	25	44 - 45				
15/ 30	191/ 143	1.0/ 1.4	91.75	3190	3900	5520	5600							
17/ 33	169/ 130	1.2/ 1.5	81.60	3300	3900	5570	5600							
18/ 35	159/ 123	1.3/ 1.6	76.50	3350	3900	5590	5600	SK 20 - 71L/4-2	18	42 - 43				
21/ 41	136/ 105	1.5/ 1.9	66.56	3440	3900	5630	5600							
22/ 44	130/ 98	1.5/ 2.0	61.80	3470	3900	5540	5600							
24/ 46	119/ 93	1.6/ 2.1	58.65	3500	3900	5460	5600							
26/ 50	110/ 86	1.8/ 2.3	53.77	3530	3900	5340	5600							
29/ 57	99/ 75	2.0/ 2.7	47.38	3560	3900	5150	5600							
33/ 64	87/ 67	2.3/ 3.0	42.13	3590	3900	4980	5600							
37/ 72	77/ 60	2.6/ 3.4	37.80	3610	3900	4810	5600							
41/ 80	70/ 54	2.8/ 3.7	34.09	3620	3900	4660	5600							
45/ 88	64/ 49	2.8/ 3.7	30.90	3550	3900	4530	5600							
49/ 97	58/ 44	2.8/ 3.7	28.12	3450	3900	4400	5600							
54/ 105	53/ 41	2.8/ 3.6	25.75	3360	3900	4300	5600							
59/ 115	49/ 37	2.8/ 3.7	23.59	3270	3900	4190	5600							
64/ 125	45/ 34	2.8/ 3.7	21.73	3190	3900	4080	5600							
69/ 135	42/ 32	2.8/ 3.6	20.09	3120	3900	3980	5600							
75/ 146	38/ 29	2.8/ 3.6	18.54	3050	3900	3890	5600							
24/ 46	119/ 93	0.8/ 1.0	58.50	1860	2500	3470	3900				SK 01 - 71L/4-2	15	42 - 43	
27/ 53	106/ 81	0.9/ 1.2	51.03	1990	2500	3360	3900							
31/ 60	92/ 72	1.1/ 1.4	45.00	2100	2500	3250	3900							
35/ 68	82/ 63	1.2/ 1.6	40.05	2160	2500	3140	3900							
38/ 75	75/ 57	1.3/ 1.7	36.00	2200	2500	3070	3900							

1) bei / at / pour F_A = 0 N

2) bei / at / pour F_Q = 0 N



STIRNRADGETRIEBEMOTOREN HELICAL GEARED MOTORS MOTOREDUCTEURS A ENGRENAGES CYLINDRIQUES

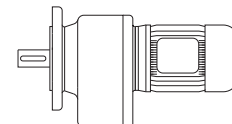

DREHSTROM, POLUMSCHALTBAR 1:2
THREE PHASE, POLE CHANGING 1:2
A COURANT TRIPHASE, A POLES COMMUTABLES 1:2

P _n [kW]	n ₂ [min ⁻¹]	M _a [Nm]	Standard f _B	i _{ges}	Normallagerung Normal bearing Roulement normal		Typenzusatz 5 Affix 5 Suffixe 5		Typ Type Type	ca. kg	Maße Dimens. Cotes				
					F _{Q N} ¹⁾ [N]	F _{A N} ²⁾ [N]	F _Q ¹⁾ [N]	F _A ²⁾ [N]							
0.30 / 0.45	43/ 83	67/ 52	1.4/ 1.8	32.58	2240	2500	2980	3900	SK 01 - 71L/4-2	15	42 - 43				
	47/ 92	61/ 47	1.4/ 1.8	29.61	2260	2500	2900	3900							
	51/ 101	56/ 43	1.4/ 1.8	27.00	2210	2500	2820	3900							
	56/ 110	51/ 39	1.4/ 1.8	24.75	2170	2500	2750	3900							
	61/ 119	47/ 36	1.4/ 1.8	22.77	2120	2500	2690	3900							
	66/ 129	43/ 33	1.4/ 1.8	20.97	2070	2500	2630	3900							
	71/ 140	40/ 31	1.4/ 1.8	19.44	2020	2500	2560	3900							
	77/ 151	37/ 28	1.4/ 1.8	18.00	1980	2500	2510	3900							
	82/ 161	35/ 27	2.7/ 3.5	16.90	1960	2500	2470	3900							
	83/ 162	35/ 27	1.4/ 1.8	16.74	1940	2500	2450	3900							
	89/ 174	32/ 25	1.4/ 1.8	15.57	1900	2500	2400	3900							
	94/ 184	30/ 23	3.3/ > 4.0	14.74	1890	2500	2380	3900							
	107/ 209	27/ 21	3.7/ > 4.0	13.00	1810	2500	2280	3900							
	120/ 235	24/ 18	> 4.0/ > 4.0	11.57	1760	2500	2210	3900							
	133/ 261	22/ 16	> 4.0/ > 4.0	10.40	1710	2500	2140	3900							
	147/ 289	19/ 15	> 4.0/ > 4.0	9.41	1650	2500	2070	3900							
	162/ 318	18/ 14	> 4.0/ > 4.0	8.55	1600	2500	2010	3900							
	178/ 348	16/ 12	> 4.0/ > 4.0	7.80	1560	2500	1960	3900							
	194/ 380	15/ 11	> 4.0/ > 4.0	7.15	1520	2500	1900	3900							
	210/ 413	14/ 10	> 4.0/ > 4.0	6.58	1480	2500	1850	3900							
	229/ 448	13/ 10	> 4.0/ > 4.0	6.06	1440	2500	1810	3900							
	246/ 483	12/ 9	> 4.0/ > 4.0	5.62	1410	2500	1760	3900							
	266/ 522	11/ 8	> 4.0/ > 4.0	5.20	1380	2500	1720	3900							
	286/ 561	10/ 8	> 4.0/ > 4.0	4.84	1340	2500	1680	3900							
	308/ 603	9/ 7	> 4.0/ > 4.0	4.50	1320	2480	1640	3860							
	321/ 630	9/ 7	> 4.0/ > 4.0	4.31	1300	2500	1620	3840							
		45/ 89	64/ 48	0.8/ 1.0	30.50	930	1620	2220				2500	SK 0 - 71L/4-2	12	42 - 43
		50/ 98	57/ 44	0.9/ 1.1	27.77	1010	1620	2210				2500			
59/ 116		49/ 37	1.0/ 1.3	23.34	1080	1620	2200	2500							
70/ 136		41/ 32	1.1/ 1.4	19.92	1140	1620	2150	2500							
81/ 159		35/ 27	1.1/ 1.4	17.12	1120	1620	2140	2500							
92/ 180		31/ 24	1.6/ 2.1	15.12	1110	1620	2270	2500							
105/ 206		27/ 21	1.8/ 2.4	13.20	1070	1620	2180	2500							
119/ 233		24/ 18	2.1/ 2.7	11.66	1040	1620	2110	2500							
148/ 290		19/ 15	2.6/ 3.4	9.35	970	1620	1960	2500							
164/ 321		17/ 13	2.9/ 3.7	8.47	950	1620	1910	2500							
180/ 352		16/ 12	3.1/ > 4.0	7.71	920	1620	1860	2500							
214/ 419		13/ 10	3.7/ > 4.0	6.48	880	1620	1760	2500							
250/ 491		11/ 9	> 4.0/ > 4.0	5.53	830	1570	1670	2500							
292/ 572		10/ 8	> 4.0/ > 4.0	4.75	800	1490	1590	2500							
0.48 / 0.60		11/ 22	417/ 260	1.0/ 1.5	124.00	6820	7650	11100	9000	SK 300 - 80S/4-2	36	44 - 45			
		13/ 25	353/ 229	1.1/ 1.7	110.91	7070	7650	10960	9000						
	14/ 28	327/ 205	1.0/ 1.6	100.00	7150	7650	10590	9000							
	15/ 31	306/ 185	1.3/ 2.2	90.77	7220	7650	10280	9000							
	17/ 34	270/ 169	1.5/ 2.3	82.86	7310	7650	10000	9000							
	18/ 37	255/ 155	1.6/ 2.6	76.00	7350	7650	9770	9000							
	19/ 39	241/ 147	1.6/ 2.6	72.10	7380	7650	9620	9000							
	22/ 44	208/ 130	1.9/ 3.1	63.86	7450	7650	9290	9000							
24/ 49	191/ 117	2.1/ 3.4	57.17	7480	7650	8980	9000								
	11/ 23	417/ 249	0.8/ 1.3	122.88	3610	5600	6820	7650	SK 250 - 80S/4-2	25	44 - 45				
	13/ 26	353/ 220	0.9/ 1.4	108.29	4050	5600	7070	7650							
	14/ 29	327/ 198	0.9/ 1.5	96.36	4200	5600	7150	7650							
	15/ 31	306/ 185	1.0/ 1.6	90.06	4300	5600	7220	7650							
	18/ 35	255/ 164	1.2/ 1.8	79.37	4530	5600	7350	7650							
	20/ 39	229/ 147	1.3/ 2.0	70.62	4620	5600	7410	7650							
	22/ 44	208/ 130	1.4/ 2.3	63.50	4690	5600	7450	7650							
	24/ 49	191/ 117	1.6/ 2.6	57.34	4740	5600	7480	7650							
	26/ 51	176/ 112	1.4/ 2.3	54.23	4780	5600	7510	7650	SK 25 - 80S/4-2	25	42 - 43				
	29/ 59	158/ 97	1.9/ 3.1	47.26	4820	5600	7540	7650							
	33/ 67	139/ 86	2.2/ 3.5	41.65	4860	5600	7510	7650							
	22/ 45	208/ 127	1.0/ 1.6	61.80	3090	3900	5330	5600	SK 20 - 80S/4-2	20	42 - 43				
	26/ 52	176/ 110	1.1/ 1.8	53.77	3270	3900	5140	5600							

1) bei / at / pour F_A = 0 N

2) bei / at / pour F_Q = 0 N

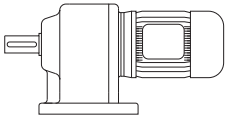

STIRNRADGETRIEBEMOTOREN HELICAL GEARED MOTORS MOTOREDUCTEURS A ENGRENAGES CYLINDRIQUES



DREHSTROM, POLUMSCHALTBAR 1:2
THREE PHASE, POLE CHANGING 1:2
A COURANT TRIPHASE, A POLES COMMUTABLES 1:2

P _n [kW]	n ₂ [min ⁻¹]	M _a [Nm]	Standard f _B	i _{ges}	Normallagerung Normal bearing Roulement normal		Typenzusatz 5 Affix 5 Suffixe 5		Typ Type Type	ca. kg	Maße Dimens. Cotes			
					F _{Q N} ¹⁾ [N]	F _{A N} ²⁾ [N]	F _Q ¹⁾ [N]	F _A ²⁾ [N]						
0.48 / 0.60	29/ 59	158/ 97	1.3/ 2.1	47.38	3350	3900	4960	5600	SK 20 - 80S/4-2	20	42 - 43			
	33/ 66	139/ 87	1.4/ 2.3	42.13	3430	3900	4820	5600						
	37/ 74	124/ 77	1.6/ 2.6	37.80	3490	3900	4670	5600						
	41/ 82	112/ 70	1.8/ 2.8	34.09	3520	3900	4540	5600						
	45/ 90	102/ 64	1.8/ 2.8	30.90	3420	3900	4410	5600						
	49/ 99	94/ 58	1.7/ 2.8	28.12	3340	3900	4300	5600						
	54/ 108	85/ 53	1.8/ 2.8	25.75	3260	3900	4190	5600						
	59/ 118	78/ 49	1.8/ 2.8	23.59	3170	3900	4080	5600						
	64/ 128	72/ 45	1.8/ 2.8	21.73	3100	3900	3990	5600						
	66/ 132	69/ 43	2.7/ > 4.0	21.12	3100	3900	3970	5600						
	69/ 139	66/ 41	1.7/ 2.8	20.09	3030	3900	3890	5600						
	75/ 150	61/ 38	1.8/ 2.8	18.54	2970	3900	3800	5600						
	76/ 152	60/ 38	3.1/ > 4.0	18.37	2970	3900	3800	5600						
	86/ 172	53/ 33	3.4/ > 4.0	16.19	2870	3900	3660	5600						
	97/ 193	47/ 30	3.9/ > 4.0	14.40	2770	3900	3530	5600						
	108/ 216	42/ 27	4.3/ 6.9	12.92	2680	3900	3410	5600						
	119/ 239	39/ 24	> 4.0/ > 4.0	11.65	2610	3900	3310	5600						
	132/ 264	35/ 22	> 4.0/ > 4.0	10.56	2520	3900	3200	5600						
	145/ 290	32/ 20	> 4.0/ > 4.0	9.61	2450	3900	3110	5600						
	158/ 316	29/ 18	> 4.0/ > 4.0	8.80	2390	3900	3040	5600						
	172/ 346	27/ 17	> 4.0/ > 4.0	8.06	2320	3900	2940	5600						
	187/ 375	25/ 15	> 4.0/ > 4.0	7.43	2260	3900	2870	5600						
	203/ 406	23/ 14	> 4.0/ > 4.0	6.86	2210	3900	2800	5600						
	211/ 423	22/ 14	> 4.0/ > 4.0	6.58	2180	3900	2770	5600						
	219/ 439	21/ 13	> 4.0/ > 4.0	6.34	2160	3900	2730	5600						
	240/ 480	19/ 12	> 4.0/ > 4.0	5.80	2100	3900	2660	5600						
	270/ 541	17/ 11	> 4.0/ > 4.0	5.15	2020	3900	2560	5600						
	301/ 603	15/ 10	> 4.0/ > 4.0	4.62	1950	3900	2470	5410						
	333/ 668	14/ 9	> 4.0/ > 4.0	4.17	1890	3740	2390	5180						
	36/ 71	127/ 81	0.8/ 1.2	39.00	1780	2500	3000	3900				SK 01 V - 80S/4-2	17	42 - 43
	40/ 80	115/ 72	0.9/ 1.4	34.75	1900	2500	2910	3900						
	45/ 89	102/ 64	1.0/ 1.6	31.20	2020	2500	2830	3900						
	49/ 99	94/ 58	1.1/ 1.7	28.24	2080	2500	2760	3900						
54/ 109	85/ 53	1.2/ 1.9	25.66	2080	2500	2680	3900							
59/ 119	78/ 48	1.3/ 2.1	23.40	2040	2500	2620	3900							
65/ 130	71/ 44	1.4/ 2.3	21.45	2000	2500	2560	3900							
70/ 141	65/ 41	1.4/ 2.3	19.73	1950	2500	2500	3900							
76/ 153	60/ 37	1.4/ 2.3	18.17	1920	2500	2450	3900							
82/ 165	56/ 35	1.7/ 2.7	16.90	1900	2500	2410	3900							
94/ 189	49/ 30	2.1/ 3.3	14.74	1830	2500	2330	3900	SK 01 - 80S/4-2	17	42 - 43				
107/ 214	43/ 27	2.3/ 3.7	13.00	1760	2500	2240	3900							
120/ 241	38/ 24	2.6/ > 4.0	11.57	1710	2500	2160	3900							
134/ 268	34/ 21	2.9/ > 4.0	10.40	1660	2500	2090	3900							
148/ 296	31/ 19	3.2/ > 4.0	9.41	1610	2500	2030	3900							
163/ 326	28/ 18	3.6/ > 4.0	8.55	1560	2500	1970	3900							
178/ 357	26/ 16	3.9/ > 4.0	7.80	1520	2500	1920	3900							
194/ 390	24/ 15	> 4.0/ > 4.0	7.15	1480	2500	1860	3900							
211/ 423	22/ 14	> 4.0/ > 4.0	6.58	1440	2500	1820	3900							
229/ 460	20/ 12	> 4.0/ > 4.0	6.06	1420	2500	1770	3900							
247/ 496	19/ 12	> 4.0/ > 4.0	5.62	1380	2500	1730	3900							
267/ 536	17/ 11	> 4.0/ > 4.0	5.20	1350	2470	1690	3900							
287/ 575	16/ 10	> 4.0/ > 4.0	4.84	1320	2420	1650	3800							
309/ 619	15/ 9	> 4.0/ > 4.0	4.50	1290	2350	1620	3710							
323/ 646	14/ 9	> 4.0/ > 4.0	4.31	1280	2380	1600	3710							
92/ 184	50/ 31	1.0/ 1.6	15.12	1050	1620	2090	2500				SK 0 - 80S/4-2	14	42 - 43	
105/ 211	44/ 27	1.1/ 1.8	13.20	1020	1620	2050	2500							
119/ 239	39/ 24	1.3/ 2.1	11.66	990	1620	2020	2500							
149/ 298	31/ 19	1.6/ 2.6	9.35	940	1620	1920	2500							
164/ 329	28/ 17	1.8/ 2.9	8.47	910	1620	1870	2500							
180/ 361	25/ 16	2.0/ 3.2	7.71	890	1560	1810	2500							
215/ 430	21/ 13	2.3/ 3.8	6.48	850	1510	1720	2500							
251/ 504	18/ 11	2.7/ > 4.0	5.53	810	1450	1640	2500							
293/ 586	16/ 10	3.1/ > 4.0	4.75	780	1360	1560	2350							
0.70 / 0.85	7.70/16.00	868/ 507	0.8/ 1.3	176.36	7850	9000	14060	12000	SK 330 - 80L/4-2	49				44 - 45
	8.60/18.00	777/ 451	0.8/ 1.3	157.90	8340	9000	13640	12000						

1) bei / at / pour F_A = 0 N

2) bei / at / pour F_Q = 0 N



STIRNRADGETRIEBEMOTOREN HELICAL GEARED MOTORS MOTOREDUCTEURS A ENGRENAGES CYLINDRIQUES

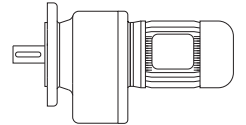

DREHSTROM, POLUMSCHALTBAR 1:2
THREE PHASE, POLE CHANGING 1:2
A COURANT TRIPHASE, A POLES COMMUTABLES 1:2

P _n [kW]	n ₂ [min ⁻¹]	M _a [Nm]	Standard f _B	i _{ges}	Normallagerung Normal bearing Roulement normal		Typenzusatz 5 Affix 5 Suffixe 5		Typ Type Type	ca. kg	Maße Dimens. Cotes
					F _{Q N} ¹⁾ [N]	F _{A N} ²⁾ [N]	F _Q ¹⁾ [N]	F _A ²⁾ [N]			
0.70 / 0.85	9.50/19.00	704/ 427	0.8/ 1.2	142.29	8690	9000	13480	12000	SK 330 - 80L/4-2	49	44 - 45
	11/ 21	608/ 387	0.8/ 1.2	128.90	9070	9000	13110	12000			
	12/ 24	557/ 338	0.8/ 1.3	117.30	9250	9000	12640	12000			
	13/ 26	514/ 312	0.8/ 1.3	107.15	9380	9000	12370	12000			
	14/ 28	478/ 290	0.8/ 1.3	98.19	9480	9000	12130	12000			
	15/ 31	446/ 262	1.6/ 2.7	89.63	9570	9000	11830	12000			
	17/ 35	393/ 232	1.8/ 3.0	79.63	9690	9000	11430	12000			
	19/ 39	352/ 208	2.0/ 3.4	71.29	9780	9000	11100	12000			
	21/ 43	318/ 189	2.2/ 3.7	64.24	9840	9000	10770	12000			
	23/ 48	291/ 169	2.4/> 4.0	58.20	9580	9000	10420	12000			
	26/ 52	257/ 156	2.7/> 4.0	52.96	9360	9000	10170	12000			
	15/ 31	446/ 262	0.9/ 1.5	90.77	6690	7650	9990	9000			
	16/ 33	418/ 246	0.9/ 1.6	82.86	6820	7650	9830	9000			
	18/ 36	371/ 225	1.1/ 1.8	76.00	7000	7650	9590	9000			
	19/ 38	352/ 214	1.1/ 1.8	72.10	7070	7650	9470	9000			
	21/ 43	318/ 189	1.3/ 2.1	63.86	7180	7650	9140	9000			
24/ 48	279/ 169	1.4/ 2.4	57.17	7290	7650	8860	9000				
26/ 54	257/ 150	1.3/ 2.2	51.50	7350	7650	8570	9000				
28/ 58	239/ 140	1.7/ 2.9	47.68	7390	7650	8400	9000				
17/ 35	393/ 232	0.8/ 1.3	79.37	3790	5600	6920	7650				
19/ 39	352/ 208	0.9/ 1.4	70.62	4060	5600	7070	7650				
21/ 44	318/ 184	0.9/ 1.6	63.50	4240	5600	7180	7650				
24/ 48	279/ 169	1.1/ 1.8	57.34	4430	5600	7290	7650				
25/ 51	267/ 159	0.9/ 1.6	54.23	4480	5600	7320	7650				
29/ 59	231/ 138	1.3/ 2.2	47.26	4620	5600	7410	7650				
33/ 67	203/ 121	1.5/ 2.5	41.65	4710	5600	7360	7650				
37/ 75	181/ 108	1.7/ 2.8	37.06	4770	5600	7110	7650				
41/ 83	163/ 98	1.8/ 3.0	33.32	4810	5600	6910	7650				
44/ 91	152/ 89	2.0/ 3.4	30.53	4840	5600	6740	7650				
50/ 102	134/ 80	2.2/ 3.8	27.16	4870	5600	6500	7650				
55/ 113	122/ 72	2.5/> 4.0	24.42	4770	5600	6300	7650				
61/ 126	110/ 64	2.7/> 4.0	22.05	4620	5600	6110	7650				
68/ 138	98/ 59	3.1/> 4.0	20.00	4500	5600	5930	7650				
29/ 58	231/ 140	0.9/ 1.4	47.38	2930	3900	4770	5600				
32/ 66	209/ 123	1.0/ 1.6	42.13	3080	3900	4630	5600				
36/ 73	186/ 111	1.1/ 1.8	37.80	3220	3900	4510	5600				
40/ 81	167/ 100	1.2/ 2.0	34.09	3310	3900	4390	5600				
44/ 90	152/ 90	1.2/ 2.0	30.90	3270	3900	4270	5600				
48/ 99	139/ 82	1.2/ 2.0	28.12	3200	3900	4160	5600				
53/ 108	126/ 75	1.2/ 2.0	25.75	3130	3900	4070	5600				
57/ 117	117/ 69	1.2/ 2.0	23.59	3070	3900	3980	5600				
62/ 127	108/ 64	1.2/ 2.0	21.73	3000	3900	3880	5600				
64/ 131	104/ 62	1.8/ 3.0	21.12	3000	3900	3880	5600				
67/ 138	100/ 59	1.2/ 2.0	20.09	2940	3900	3790	5600				
73/ 149	92/ 54	1.2/ 2.0	18.54	2880	3900	3720	5600				
74/ 151	90/ 54	2.0/ 3.4	18.37	2890	3900	3720	5600				
84/ 171	80/ 47	2.3/ 3.9	16.19	2800	3900	3600	5600				
94/ 192	71/ 42	2.6/> 4.0	14.40	2710	3900	3470	5600				
105/ 214	64/ 38	2.9/> 4.0	12.92	2620	3900	3360	5600				
116/ 238	58/ 34	3.1/> 4.0	11.65	2550	3900	3260	5600				
128/ 262	52/ 31	3.1/> 4.0	10.56	2480	3900	3170	5600				
141/ 288	47/ 28	3.1/> 4.0	9.61	2410	3900	3080	5600				
154/ 315	43/ 26	3.1/> 4.0	8.80	2340	3900	2990	5600				
168/ 344	40/ 24	3.1/> 4.0	8.06	2280	3900	2920	5600				
182/ 373	37/ 22	3.1/> 4.0	7.43	2230	3900	2840	5600				
198/ 404	34/ 20	3.1/> 4.0	6.86	2180	3900	2770	5600				
206/ 421	32/ 19	> 4.0/> 4.0	6.58	2160	3900	2750	5600				
214/ 437	31/ 19	3.1/> 4.0	6.34	2130	3900	2700	5600				
234/ 478	29/ 17	> 4.0/> 4.0	5.80	2080	3900	2640	5600				
263/ 538	25/ 15	> 4.0/> 4.0	5.15	2000	3900	2540	5510				
293/ 600	23/ 14	> 4.0/> 4.0	4.62	1930	3750	2450	5260				
325/ 664	21/ 12	> 4.0/> 4.0	4.17	1880	3630	2380	5080				
53/ 108	126/ 75	0.8/ 1.3	25.66	820	2320	2560	3900				
								SK 01 V - 80L/4-2	19	42 - 43	

1) bei / at / pour F_A = 0 N

2) bei / at / pour F_Q = 0 N

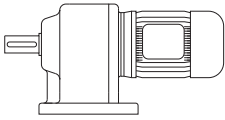

STIRNRADGETRIEBEMOTOREN HELICAL GEARED MOTORS MOTOREDUCTEURS A ENGRENAGES CYLINDRIQUES



DREHSTROM, POLUMSCHALTBAR 1:2
THREE PHASE, POLE CHANGING 1:2
A COURANT TRIPHASE, A POLES COMMUTABLES 1:2

P _n [kW]	n ₂ [min ⁻¹]	M _a [Nm]	Standard f _B	i _{ges}	Normallagerung Normal bearing Roulement normal		Typenzusatz 5 Affix 5 Suffixe 5		Typ Type Type	ca. kg	Maße Dimens. Cotes			
					F _{Q N} ¹⁾ [N]	F _{A N} ²⁾ [N]	F _Q ¹⁾ [N]	F _A ²⁾ [N]						
0.70 / 0.85	58/ 118	115/ 69	0.9/ 1.5	23.40	1030	2420	2510	3900	SK 01 V - 80L/4-2	19	42 - 43			
	63/ 129	106/ 63	0.9/ 1.6	21.45	1170	2500	2450	3900						
	69/ 140	97/ 58	1.0/ 1.6	19.73	1300	2500	2400	3900						
	75/ 152	89/ 53	1.0/ 1.6	18.17	1420	2500	2360	3900						
	80/ 164	84/ 49	1.1/ 1.9	16.90	1820	2500	2340	3900	SK 01 - 80L/4-2	19	42 - 43			
	92/ 188	73/ 43	1.4/ 2.3	14.74	1760	2500	2250	3900						
	104/ 213	64/ 38	1.6/ 2.6	13.00	1700	2500	2180	3900						
	117/ 239	57/ 34	1.8/ 2.9	11.57	1650	2500	2110	3900						
	130/ 266	51/ 31	1.9/ 3.3	10.40	1600	2500	2040	3900						
	144/ 294	46/ 28	2.2/ 3.6	9.41	1570	2500	1980	3900						
	158/ 324	42/ 25	2.4/ 4.0	8.55	1520	2500	1930	3900						
	174/ 355	38/ 23	2.6/> 4.0	7.80	1480	2500	1880	3900						
	190/ 387	35/ 21	2.8/> 4.0	7.15	1450	2500	1830	3900						
	206/ 421	32/ 19	3.1/> 4.0	6.58	1420	2470	1790	3900						
	224/ 457	30/ 18	3.0/> 4.0	6.06	1380	2390	1740	3900						
	241/ 493	28/ 16	3.1/> 4.0	5.62	1350	2360	1710	3830						
	261/ 533	26/ 15	3.1/> 4.0	5.20	1330	2290	1670	3720						
	280/ 572	24/ 14	3.1/> 4.0	4.84	1290	2230	1630	3630						
	301/ 616	22/ 13	3.1/> 4.0	4.50	1270	2180	1590	3520						
	314/ 643	21/ 13	> 4.0/> 4.0	4.31	1250	2230	1580	3550						
	103/ 210	65/ 39	0.8/ 1.3	13.20	340	1120	1560	2500	SK 0 - 80L/4-2	16	42 - 43			
	116/ 238	58/ 34	0.9/ 1.5	11.66	480	1190	1630	2500						
	145/ 296	46/ 27	1.1/ 1.8	9.35	700	1320	1690	2500						
	160/ 327	42/ 25	1.2/ 2.0	8.47	760	1290	1660	2500						
	176/ 359	38/ 23	1.3/ 2.2	7.71	820	1270	1630	2470						
	209/ 427	32/ 19	1.6/ 2.6	6.48	810	1260	1610	2370						
	245/ 501	27/ 16	1.8/ 3.1	5.53	780	1230	1580	2280						
	285/ 583	23/ 14	2.1/ 3.5	4.75	750	1170	1520	2150						
1.10 / 1.40	16/ 31	657/ 431	1.1/ 1.6	89.63	8880	9000	11190	12000				SK 330 - 90S/4-2	51	44 - 45
	18/ 35	584/ 382	1.2/ 1.8	79.63	9160	9000	10870	12000						
	20/ 39	525/ 343	1.3/ 2.0	71.29	9350	9000	10560	12000						
	22/ 43	478/ 311	1.5/ 2.3	64.24	9400	9000	10310	12000						
	24/ 48	438/ 279	1.6/ 2.5	58.20	9140	9000	10010	12000	SK 33 - 90S/4-2	39	42 - 43			
	25/ 50	420/ 267	1.6/ 2.5	55.78	9100	9000	9930	12000						
	29/ 57	362/ 235	1.9/ 3.0	48.50	8780	9000	9580	12000						
	33/ 65	318/ 206	2.2/ 3.4	42.68	8480	9000	9240	12000						
	37/ 73	284/ 183	2.3/ 3.6	37.93	8200	9000	8930	12000	SK 30 - 90S/4-2	31	42 - 43			
	22/ 44	478/ 304	0.8/ 1.3	63.86	6540	7650	8650	9000						
	24/ 49	438/ 273	0.9/ 1.5	57.17	6730	7650	8410	9000						
	27/ 54	389/ 248	0.9/ 1.4	51.50	6930	7650	8200	9000						
	29/ 58	362/ 231	1.1/ 1.7	47.68	7030	7650	8060	9000						
	33/ 65	318/ 206	1.3/ 1.9	42.68	7180	7650	7810	9000						
	36/ 72	292/ 186	1.1/ 1.8	38.45	7000	7650	7590	9000						
	40/ 80	263/ 167	1.5/ 2.4	34.91	6810	7650	7370	9000						
	44/ 87	239/ 154	1.7/ 2.6	31.84	6650	7650	7200	9000						
	48/ 95	219/ 141	1.8/ 2.8	29.22	6490	7650	7010	9000						
	30/ 59	350/ 227	0.9/ 1.3	47.26	4070	5600	7080	7650	SK 25 - 90S/4-2	29	42 - 43			
	34/ 67	309/ 200	1.0/ 1.5	41.65	4290	5600	6990	7650						
	38/ 75	276/ 178	1.1/ 1.7	37.06	4440	5600	6790	7650						
	42/ 83	250/ 161	1.2/ 1.8	33.32	4550	5600	6610	7650						
	46/ 91	228/ 147	1.3/ 2.0	30.53	4630	5600	6460	7650						
	52/ 102	202/ 131	1.5/ 2.3	27.16	4690	5600	6270	7650						
	57/ 114	184/ 117	1.6/ 2.6	24.42	4550	5600	6080	7650						
	63/ 126	167/ 106	1.8/ 2.8	22.05	4420	5600	5910	7650						
	70/ 139	150/ 96	2.0/ 3.1	20.00	4300	5600	5740	7650						
	77/ 152	136/ 88	2.0/ 3.1	18.27	4200	5600	5600	7650						
	84/ 166	125/ 81	2.0/ 3.1	16.75	4100	5600	5450	7650						
	43/ 85	244/ 157	0.8/ 1.3	32.72	1960	3900	4000	5600				SK 20 V - 90S/4-2	27	42 - 43
	45/ 90	233/ 149	0.9/ 1.3	30.90	2480	3900	3980	5600						
	48/ 95	219/ 141	0.9/ 1.4	29.33	2290	3900	3900	5600						
	51/ 102	206/ 131	1.0/ 1.5	27.23	2830	3900	3860	5600						

1) bei / at / pour F_A = 0 N

2) bei / at / pour F_Q = 0 N



STIRNRADGETRIEBEMOTOREN HELICAL GEARED MOTORS MOTOREDUCTEURS A ENGRENAGES CYLINDRIQUES

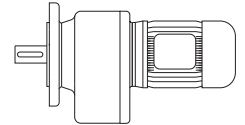

DREHSTROM, POLUMSCHALTBAR 1:2
THREE PHASE, POLE CHANGING 1:2
A COURANT TRIPHASE, A POLES COMMUTABLES 1:2

P _n [kW]	n ₂ [min ⁻¹]	M _a [Nm]	Standard f _B	i _{ges}	Normallagerung Normal bearing Roulement normal		Typenzusatz 5 Affix 5 Suffixe 5		Typ Type Type	ca. kg	Maße Dimens. Cotes				
					F _{Q N} ¹⁾ [N]	F _{A N} ²⁾ [N]	F _Q ¹⁾ [N]	F _A ²⁾ [N]							
1.10 / 1.40	53/ 105	198/ 127	1.0/ 1.6	26.46	2540	3900	3830	5600	SK 20 V - 90S/4-2	27	42 - 43				
	58/ 115	181/ 116	1.1/ 1.7	24.21	2840	3900	3760	5600							
	64/ 128	164/ 104	1.2/ 1.9	21.73	2780	3900	3680	5600							
		66/ 132	159/ 101	1.2/ 1.8	21.12	2770	3900	3660	5600	SK 20 - 90S/4-2	24	42 - 43			
		76/ 151	138/ 89	1.3/ 2.1	18.37	2700	3900	3540	5600						
		86/ 172	122/ 78	1.5/ 2.4	16.19	2620	3900	3420	5600						
		97/ 193	108/ 69	1.7/ 2.6	14.40	2550	3900	3320	5600						
		108/ 215	97/ 62	1.9/ 2.9	12.92	2480	3900	3230	5600						
		120/ 239	88/ 56	2.1/ 3.2	11.65	2420	3900	3130	5600						
		133/ 263	79/ 51	2.1/ 3.2	10.56	2360	3900	3050	5600						
		146/ 289	72/ 46	2.1/ 3.2	9.61	2300	3900	2980	5600						
		159/ 316	66/ 42	2.1/ 3.2	8.80	2250	3900	2900	5600						
		174/ 345	60/ 39	2.1/ 3.2	8.06	2190	3860	2820	5600						
		188/ 374	56/ 36	2.1/ 3.2	7.43	2140	3780	2760	5600						
		204/ 405	51/ 33	2.1/ 3.2	6.86	2100	3690	2700	5490						
		213/ 422	49/ 32	2.7/ 4.2	6.58	2080	3900	2680	5600						
		221/ 438	48/ 31	2.1/ 3.2	6.34	2050	3580	2630	5320						
		241/ 479	44/ 28	3.1/ > 4.0	5.80	2010	3740	2580	5430						
		272/ 540	39/ 25	3.2/ > 4.0	5.15	1940	3590	2490	5180						
		303/ 602	35/ 22	3.2/ > 4.0	4.62	1880	3490	2410	5010						
336/ 667		31/ 20	3.2/ > 4.0	4.17	1830	3350	2330	4800							
		95/ 189	111/ 71	0.9/ 1.4	14.74	800	1860	2090	3900				SK 01 - 90S/4-2	21	42 - 43
		108/ 214	97/ 62	1.0/ 1.6	13.00	1080	2010	2040	3900						
	121/ 240	87/ 56	1.2/ 1.8	11.57	1240	2010	1980	3900							
	135/ 267	78/ 50	1.3/ 2.0	10.40	1380	2020	1930	3900							
	149/ 295	71/ 45	1.4/ 2.2	9.41	1450	2040	1890	3820							
	164/ 325	64/ 41	1.6/ 2.4	8.55	1420	2010	1840	3740							
	179/ 356	59/ 38	1.7/ 2.7	7.80	1390	1980	1790	3630							
	196/ 389	54/ 34	1.9/ 2.9	7.15	1360	1980	1750	3570							
	213/ 422	49/ 32	2.0/ 3.1	6.58	1330	1920	1710	3460							
	231/ 459	45/ 29	2.0/ 3.1	6.06	1310	1920	1680	3410							
	249/ 495	42/ 27	2.0/ 3.1	5.62	1280	1880	1640	3320							
	269/ 535	39/ 25	2.0/ 3.1	5.20	1250	1840	1600	3240							
	289/ 574	36/ 23	2.0/ 3.1	4.84	1230	1820	1570	3180							
	311/ 618	34/ 22	2.0/ 3.1	4.50	1210	1770	1540	3090							
	325/ 645	32/ 21	2.8/ > 4.0	4.31	1200	1920	1530	3220							
	1.50 / 1.90	17/ 35	843/ 518	0.8/ 1.4	79.63	7990	9000	10340	12000	SK 330 - 90L/4-2	55	44 - 45			
19/ 39		754/ 465	0.9/ 1.5	71.29	8460	9000	10100	12000							
21/ 43		682/ 422	1.0/ 1.7	64.24	8780	9000	9860	12000							
24/ 48		597/ 378	1.2/ 1.9	58.20	8750	9000	9610	12000							
		25/ 50	573/ 363	1.2/ 1.8	55.78	8730	9000	9580	12000	SK 33 - 90L/4-2	43	42 - 43			
	28/ 57	512/ 318	1.4/ 2.2	48.50	8460	9000	9270	12000							
	32/ 65	448/ 279	1.6/ 2.5	42.68	8190	9000	8960	12000							
	36/ 73	398/ 249	1.6/ 2.6	37.93	7960	9000	8690	12000							
	41/ 82	349/ 221	1.7/ 2.6	33.95	7710	9000	8430	12000							
	45/ 91	318/ 199	1.6/ 2.6	30.56	7500	9000	8180	12000							
	50/ 100	286/ 181	1.7/ 2.6	27.74	7320	9000	7970	12000							
	55/ 110	260/ 165	1.7/ 2.6	25.22	7120	9000	7760	12000							
	60/ 120	239/ 151	1.7/ 2.6	23.09	6950	9000	7560	12000							
	27/ 54	531/ 336	0.8/ 1.2	51.46	6250	7650	7900	9000	SK 30 V - 90L/4-2				38	42 - 43	
	29/ 58	494/ 313	0.8/ 1.3	47.68	6460	7650	7760	9000	SK 30 - 90L/4-2	35	42 - 43				
	32/ 65	448/ 279	0.9/ 1.4	42.68	6690	7650	7540	9000							
	36/ 72	398/ 252	0.8/ 1.3	38.45	6750	7650	7360	9000							
	40/ 79	358/ 230	1.1/ 1.7	34.91	6600	7650	7170	9000							
	43/ 87	333/ 209	1.2/ 1.9	31.84	6440	7650	6990	9000							
	47/ 95	305/ 191	1.3/ 2.1	29.22	6300	7650	6830	9000							
	51/ 103	281/ 176	1.4/ 2.3	26.92	6160	7650	6700	9000							
	55/ 111	260/ 163	1.4/ 2.3	24.89	6040	7650	6550	9000							
	60/ 120	239/ 151	1.4/ 2.3	23.08	5910	7650	6410	9000							
	64/ 129	224/ 141	1.4/ 2.3	21.46	5790	7650	6270	9000							
	65/ 130	220/ 140	1.7/ 2.8	21.28	5810	7650	6290	9000							
	69/ 139	208/ 131	1.4/ 2.3	20.00	5670	7650	6140	9000							
	73/ 147	196/ 123	2.0/ 3.2	18.85	5620	7650	6080	9000							

1) bei / at / pour F_A = 0 N

2) bei / at / pour F_Q = 0 N

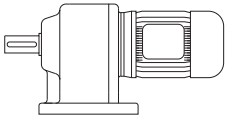

STIRNRADGETRIEBMOTOREN HELICAL GEARED MOTORS MOTOREDUCTEURS A ENGRENAGES CYLINDRIQUES



DREHSTROM, POLUMSCHALTBAR 1:2
THREE PHASE, POLE CHANGING 1:2
A COURANT TRIPHASE, A POLES COMMUTABLES 1:2

P _n [kW]	n ₂ [min ⁻¹]	M _a [Nm]	Standard f _B	i _{ges}	Normallagerung Normal bearing Roulement normal		Typenzusatz 5 Affix 5 Suffixe 5		Typ Type Type	ca. kg	Maße Dimens. Cotes			
					F _{Q N} ¹⁾ [N]	F _{A N} ²⁾ [N]	F _Q ¹⁾ [N]	F _A ²⁾ [N]						
1.50 / 1.90	45/ 91	318/ 199	0.9/ 1.5	30.53	4240	5600	6230	7650	SK 25 - 90L/4-2	33	42 - 43			
	51/ 102	281/ 178	1.1/ 1.7	27.16	4420	5600	6060	7650						
	57/ 114	251/ 159	1.2/ 1.9	24.42	4360	5600	5880	7650						
	63/ 126	227/ 144	1.3/ 2.1	22.05	4250	5600	5740	7650						
	69/ 139	208/ 131	1.4/ 2.3	20.00	4150	5600	5580	7650						
	76/ 152	188/ 119	1.5/ 2.3	18.27	4050	5600	5450	7650						
	78/ 158	184/ 115	1.4/ 2.2	17.61	4050	5600	5430	7650						
	82/ 166	175/ 109	1.4/ 2.3	16.75	3970	5600	5330	7650						
	90/ 181	159/ 100	1.9/ 3.0	15.35	3900	5600	5220	7650						
	102/ 205	140/ 89	2.1/ 3.4	13.52	3770	5600	5030	7650						
	115/ 231	125/ 79	2.4/ 3.8	12.03	3650	5600	4880	7650						
	65/ 131	220/ 139	0.8/ 1.4	21.12	1870	3450	3460	5600				SK 20 - 90L/4-2	28	42 - 43
	75/ 151	191/ 120	1.0/ 1.5	18.37	2280	3630	3370	5600						
	85/ 171	169/ 106	1.1/ 1.7	16.19	2460	3660	3270	5600						
96/ 193	149/ 94	1.2/ 1.9	14.40	2400	3660	3180	5600							
107/ 215	134/ 84	1.4/ 2.2	12.92	2350	3640	3110	5600							
118/ 238	121/ 76	1.5/ 2.4	11.65	2300	3590	3030	5600							
131/ 263	109/ 69	1.5/ 2.4	10.56	2250	3550	2950	5600							
144/ 289	99/ 63	1.5/ 2.4	9.61	2200	3490	2880	5540							
157/ 315	91/ 58	1.5/ 2.4	8.80	2160	3410	2820	5390							
171/ 344	84/ 53	1.5/ 2.4	8.06	2110	3350	2750	5260							
186/ 373	77/ 49	1.5/ 2.4	7.43	2070	3290	2690	5130							
201/ 405	71/ 45	1.5/ 2.4	6.86	2030	3220	2630	5010							
210/ 422	68/ 43	1.9/ 3.1	6.58	2020	3550	2620	5300							
218/ 438	66/ 41	1.5/ 2.4	6.34	1990	3180	2580	4910							
238/ 478	60/ 38	2.2/ 3.5	5.80	1960	3430	2520	5110							
268/ 539	53/ 34	2.3/ 3.6	5.15	1900	3310	2440	4910							
299/ 601	48/ 30	2.3/ 3.6	4.62	1840	3220	2360	4730							
331/ 665	43/ 27	2.3/ 3.6	4.17	1790	3130	2300	4580							
119/ 240	120/ 76	0.8/ 1.3	11.57	—	—	1460	3150	SK 01 - 90L/4-2	25	42 - 43				
133/ 267	108/ 68	0.9/ 1.5	10.40	80	1060	1580	3160							
147/ 295	97/ 62	1.0/ 1.6	9.41	330	1210	1700	3120							
161/ 325	89/ 56	1.1/ 1.8	8.55	470	1270	1750	3120							
177/ 356	81/ 51	1.2/ 2.0	7.80	620	1350	1710	3090							
193/ 388	74/ 47	1.3/ 2.1	7.15	760	1430	1680	3020							
210/ 422	68/ 43	1.5/ 2.3	6.58	850	1470	1640	2990							
228/ 458	63/ 40	1.4/ 2.3	6.06	900	1460	1610	2930							
246/ 494	58/ 37	1.5/ 2.3	5.62	990	1460	1580	2880							
265/ 534	54/ 34	1.5/ 2.3	5.20	1030	1460	1550	2840							
285/ 573	50/ 32	1.5/ 2.3	4.84	1080	1430	1520	2770							
307/ 617	47/ 29	1.5/ 2.3	4.50	1080	1450	1490	2760							
320/ 644	45/ 28	2.0/ 3.2	4.31	1160	1650	1490	2940							
2.00 / 2.40	25/ 51	764/ 449	0.9/ 1.5	55.78	8330	9000	9180				12000	SK 33 - 100L/4-2	49	42 - 43
	29/ 58	659/ 395	1.1/ 1.8	48.50	8110	9000	8910	12000						
	33/ 66	579/ 347	1.2/ 2.0	42.68	7870	9000	8650	12000						
	37/ 75	516/ 306	1.3/ 2.1	37.93	7650	9000	8410	12000						
	41/ 83	466/ 276	1.2/ 2.1	33.95	7460	9000	8180	12000						
	46/ 93	415/ 246	1.3/ 2.1	30.56	7270	9000	7940	12000						
	50/ 102	382/ 225	1.2/ 2.1	27.74	7080	9000	7740	12000						
	56/ 112	341/ 205	1.3/ 2.1	25.22	6910	9000	7550	12000						
	61/ 123	313/ 186	1.3/ 2.1	23.09	6740	9000	7360	12000						
	66/ 134	289/ 171	1.3/ 2.1	21.15	6590	9000	7180	12000						
	72/ 146	265/ 157	1.3/ 2.1	19.40	6430	9000	7010	12000						
2.00 / 2.40	37/ 75	516/ 306	0.8/ 1.3	37.68	6340	7650	7020	9000	SK 30 V - 100L/4-2	44	42 - 43			
	41/ 82	466/ 280	0.9/ 1.4	34.39	6300	7650	6880	9000						
	44/ 90	434/ 255	0.9/ 1.6	31.54	6170	7650	6720	9000						
	48/ 97	398/ 236	1.0/ 1.7	29.05	6060	7650	6600	9000						
	52/ 105	367/ 218	1.1/ 1.8	26.89	5950	7650	6480	9000						
	56/ 114	341/ 201	1.1/ 1.9	24.90	5820	7650	6330	9000						
	60/ 122	318/ 188	1.1/ 1.9	23.16	5720	7650	6230	9000						
	65/ 131	294/ 175	1.2/ 1.9	21.58	5620	7650	6120	9000						
	66/ 133	289/ 172	1.3/ 2.2	21.28	5640	7650	6120	9000				SK 30 - 100L/4-2	41	42 - 43
	74/ 150	258/ 153	1.5/ 2.6	18.85	5460	7650	5920	9000						

1) bei / at / pour F_A = 0 N

2) bei / at / pour F_Q = 0 N



STIRNRADGETRIEBEMOTOREN HELICAL GEARED MOTORS MOTOREDUCTEURS A ENGRENAGES CYLINDRIQUES

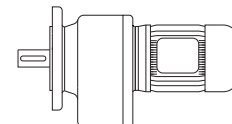

DREHSTROM, POLUMSCHALTBAR 1:2
THREE PHASE, POLE CHANGING 1:2
A COURANT TRIPHASE, A POLES COMMUTABLES 1:2

P _n [kW]	n ₂ [min ⁻¹]	M _a [Nm]	Standard f _B	i _{ges}	Normallagerung Normal bearing Roulement normal		Typenzusatz 5 Affix 5 Suffixe 5		Typ Type Type	ca. kg	Maße Dimens. Cotes				
					F _{Q N} ¹⁾ [N]	F _{A N} ²⁾ [N]	F _Q ¹⁾ [N]	F _A ²⁾ [N]							
2.00 / 2.40	83/ 168	230/ 136	1.7/ 2.9	16.87	5310	7650	5740	9000	SK 30 - 100L/4-2	41	42 - 43				
	92/ 186	208/ 123	1.6/ 2.7	15.20	5160	7650	5580	9000							
	101/ 205	189/ 112	2.0/ 3.4	13.80	5010	7650	5440	9000							
	80/ 161	239/ 142	1.1/ 1.8	17.61	3890	5600	5260	7650	SK 25 - 100L/4-2	39	42 - 43				
	91/ 184	210/ 125	1.4/ 2.4	15.35	3770	5600	5070	7650							
	104/ 209	184/ 110	1.6/ 2.7	13.52	3650	5600	4910	7650							
	116/ 235	165/ 98	1.8/ 3.1	12.03	3540	5600	4750	7650							
	129/ 262	148/ 87	2.0/ 3.4	10.82	3450	5560	4620	7650							
	143/ 290	134/ 79	2.2/ 3.8	9.77	3350	5430	4480	7650							
	158/ 319	121/ 72	2.4/ > 4.0	8.86	3270	5280	4360	7600							
	173/ 350	110/ 65	2.4/ > 4.0	8.09	3190	5180	4250	7420							
	189/ 381	101/ 60	2.4/ > 4.0	7.42	3120	5060	4150	7190							
	205/ 415	93/ 55	2.4/ > 4.0	6.82	3040	4920	4040	6990							
	223/ 450	86/ 51	2.4/ > 4.0	6.29	2960	4800	3940	6790							
	241/ 486	79/ 47	2.4/ > 4.0	5.82	2910	4690	3850	6640							
	260/ 526	73/ 44	2.4/ > 4.0	5.38	2830	4570	3750	6440							
	280/ 566	68/ 40	2.4/ > 4.0	5.00	2780	4480	3680	6280							
	302/ 610	63/ 38	2.4/ > 4.0	4.64	2710	4340	3590	6080							
	323/ 654	59/ 35	2.4/ > 4.0	4.33	2660	4250	3520	5930							
	347/ 702	55/ 33	2.4/ > 4.0	4.03	2600	4120	3440	5760							
		86/ 175	222/ 131	0.8/ 1.4	16.19	690	2080	3080				5280	SK 20 - 100L/4-2	34	42 - 43
		97/ 197	197/ 116	0.9/ 1.6	14.40	1110	2340	3040				5260			
		108/ 219	177/ 105	1.0/ 1.7	12.92	1390	2520	2970				5170			
120/ 243		159/ 94	1.1/ 1.9	11.65	1660	2680	2900	5120							
133/ 268		144/ 86	1.1/ 1.9	10.56	1840	2780	2830	5010							
146/ 294		131/ 78	1.1/ 1.9	9.61	1980	2840	2780	4950							
159/ 322		120/ 71	1.1/ 1.9	8.80	2060	2900	2720	4860							
174/ 351		110/ 65	1.1/ 1.9	8.06	2020	2880	2660	4760							
188/ 381		102/ 60	1.1/ 1.9	7.43	1980	2840	2600	4660							
204/ 413		94/ 55	1.1/ 1.9	6.86	1950	2820	2550	4570							
213/ 430		90/ 53	1.5/ 2.5	6.58	1950	3190	2550	4930							
221/ 446		86/ 51	1.1/ 1.9	6.34	1910	2760	2500	4480							
241/ 488		79/ 47	1.7/ 2.8	5.80	1890	3120	2460	4760							
272/ 550		70/ 42	1.7/ 2.9	5.15	1840	3020	2380	4580							
303/ 613		63/ 37	1.7/ 2.9	4.62	1790	2960	2310	4450							
336/ 679		57/ 34	1.7/ 2.9	4.17	1740	2870	2240	4300							
370/ 749		52/ 31	1.7/ 2.9	3.78	1690	2780	2180	4170							
2.60 / 3.10		40/ 82	621/ 361	1.1/ 1.8	34.50	7190	9000	7920	12000	SK 33 V - 100L/40-20	57	42 - 43			
	45/ 93	552/ 318	1.2/ 2.1	30.36	6990	9000	7680	12000							
	51/ 105	487/ 282	1.2/ 2.1	26.98	6800	9000	7460	12000							
	57/ 117	436/ 253	1.2/ 2.1	24.15	6620	9000	7270	12000							
	63/ 130	394/ 228	1.2/ 2.1	21.74	6460	9000	7070	12000							
	70/ 143	355/ 207	1.2/ 2.1	19.73	6300	9000	6890	12000							
	77/ 157	322/ 189	1.5/ 2.6	17.94	6180	9000	6750	12000							
88/ 181	282/ 164	1.7/ 3.0	15.60	5960	9000	6500	12000								
	65/ 133	382/ 223	1.0/ 1.7	21.28	5450	7650	5930	9000	SK 30 - 100L/40-20	43	42 - 43				
	73/ 150	340/ 197	1.2/ 2.0	18.85	5290	7650	5760	9000							
	82/ 167	303/ 177	1.3/ 2.2	16.87	5160	7650	5610	9000							
	91/ 186	273/ 159	1.2/ 2.1	15.20	5020	7650	5450	9000							
	100/ 205	248/ 144	1.5/ 2.6	13.80	4890	7650	5310	9000							
	110/ 224	226/ 132	1.7/ 2.8	12.59	4780	7650	5170	9000							
	119/ 245	209/ 121	1.8/ 3.1	11.55	4660	7650	5050	9000							
	130/ 266	191/ 111	1.9/ 3.3	10.64	4560	7650	4940	9000							
	140/ 287	177/ 103	2.0/ 3.4	9.85	4460	7650	4830	9000							
	151/ 310	164/ 96	2.0/ 3.4	9.12	4360	7520	4720	8770							
	163/ 333	152/ 89	2.0/ 3.4	8.48	4270	7370	4630	8590							
	175/ 358	142/ 83	2.0/ 3.4	7.90	4190	7200	4530	8380							
	197/ 402	126/ 74	2.3/ 3.9	7.02	4060	7270	4400	8400							
	220/ 451	113/ 66	2.5/ > 4.0	6.27	3930	7010	4250	8080							
	244/ 500	102/ 59	2.8/ > 4.0	5.65	3820	6790	4120	7810							
	269/ 551	92/ 54	2.9/ > 4.0	5.13	3700	6560	4000	7530							
	295/ 604	84/ 49	2.9/ > 4.0	4.68	3600	6370	3900	7290							
	322/ 659	77/ 45	2.9/ > 4.0	4.29	3510	6180	3780	7070							

1) bei / at / pour F_A = 0 N

2) bei / at / pour F_Q = 0 N

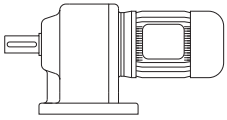

STIRNRADGETRIEBEMOTOREN HELICAL GEARED MOTORS MOTOREDUCTEURS A ENGRENAGES CYLINDRIQUES



DREHSTROM, POLUMSCHALTBAR 1:2
THREE PHASE, POLE CHANGING 1:2
A COURANT TRIPHASE, A POLES COMMUTABLES 1:2

P _n [kW]	n ₂ [min ⁻¹]	M _a [Nm]	Standard f _B	i _{ges}	Normallagerung Normal bearing Roulement normal		Typenzusatz 5 Affix 5 Suffixe 5		Typ Type Type	ca. kg	Maße Dimens. Cotes				
					F _{Q N} ¹⁾ [N]	F _{A N} ²⁾ [N]	F _Q ¹⁾ [N]	F _A ²⁾ [N]							
2.60 / 3.10	78/ 160	318/ 185	0.8/ 1.4	17.61	2610	4380	5070	7650	SK 25 - 100L/40-20	41	42 - 43				
	90/ 184	276/ 161	1.1/ 1.9	15.35	3180	4670	4920	7650							
	102/ 209	243/ 142	1.2/ 2.1	13.52	3510	4870	4760	7650							
	115/ 235	216/ 126	1.4/ 2.4	12.03	3420	4860	4620	7460							
	128/ 261	194/ 113	1.5/ 2.6	10.82	3340	4800	4500	7340							
	141/ 289	176/ 102	1.7/ 2.9	9.77	3250	4760	4380	7140							
	156/ 319	159/ 93	1.8/ 3.1	8.86	3170	4660	4260	6980							
	171/ 349	145/ 85	1.8/ 3.1	8.09	3100	4570	4150	6780							
	186/ 381	133/ 78	1.8/ 3.1	7.42	3030	4480	4060	6640							
	202/ 414	123/ 72	1.8/ 3.1	6.82	2960	4380	3960	6450							
	219/ 449	113/ 66	1.8/ 3.1	6.29	2900	4310	3870	6310							
	237/ 485	105/ 61	1.8/ 3.1	5.82	2840	4220	3790	6180							
	257/ 525	97/ 56	1.8/ 3.1	5.38	2780	4150	3700	6010							
	276/ 565	90/ 52	1.8/ 3.1	5.00	2720	4060	3620	5880							
	297/ 609	84/ 49	1.8/ 3.1	4.64	2660	3960	3540	5700							
	319/ 652	78/ 45	1.8/ 3.1	4.33	2610	3890	3470	5580							
	342/ 701	73/ 42	1.8/ 3.1	4.03	2560	3810	3390	5430							
3.70 / 4.40	42/ 84	841/ 500	0.8/ 1.3	34.50	2750	6770	6020	12000	SK 33 V - 112M/4-2	62	42 - 43				
	47/ 96	752/ 438	0.9/ 1.5	30.36	3800	7270	6580	12000							
	53/ 108	667/ 389	0.9/ 1.5	26.98	4720	7810	6980	12000							
	59/ 120	599/ 350	0.9/ 1.5	24.15	5370	8130	6820	12000							
	66/ 134	535/ 314	0.9/ 1.5	21.74	5960	8460	6660	12000							
	73/ 147	484/ 286	0.9/ 1.5	19.73	5910	8460	6530	11920							
		80/ 162	442/ 259	1.1/ 1.9	17.94	5860	9000	6420				12000	SK 33 - 112M/4-2	56	42 - 43
		92/ 186	384/ 226	1.3/ 2.2	15.60	5650	9000	6220				12000			
		105/ 212	337/ 198	1.5/ 2.5	13.73	5480	8820	6000				11880			
		118/ 238	299/ 177	1.6/ 2.8	12.20	5320	8640	5820				11520			
131/ 266		270/ 158	1.8/ 3.1	10.92	5170	8380	5650	11180							
	76/ 154	465/ 273	0.8/ 1.4	18.85	4310	7060	5420	8820	SK 30 - 112M/4-2	48	42 - 43				
	85/ 172	416/ 244	0.9/ 1.6	16.87	4830	7120	5290	8730							
	94/ 191	376/ 220	0.9/ 1.5	15.20	4720	7070	5170	8590							
	104/ 211	340/ 199	1.1/ 1.9	13.80	4620	7000	5040	8460							
	114/ 231	310/ 182	1.2/ 2.1	12.59	4520	6920	4940	8310							
	124/ 252	285/ 167	1.3/ 2.2	11.55	4440	6840	4830	8210							
	135/ 273	262/ 154	1.4/ 2.4	10.64	4360	6720	4720	8050							
	146/ 295	242/ 142	1.5/ 2.5	9.85	4260	6640	4630	7900							
	157/ 319	225/ 132	1.4/ 2.5	9.12	4170	6510	4540	7740							
	169/ 343	209/ 123	1.5/ 2.5	8.48	4090	6390	4440	7580							
	182/ 368	194/ 114	1.5/ 2.5	7.90	4020	6310	4360	7460							
	204/ 414	173/ 101	1.7/ 2.8	7.02	3930	6570	4260	7670							
	229/ 463	154/ 91	1.9/ 3.2	6.27	3800	6370	4110	7420							
	254/ 514	139/ 82	2.0/ 3.5	5.65	3690	6190	3990	7200							
	280/ 566	126/ 74	2.1/ 3.6	5.13	3600	6020	3890	6980							
	307/ 621	115/ 68	2.1/ 3.6	4.68	3500	5840	3780	6770							
	334/ 677	106/ 62	2.1/ 3.6	4.29	3410	5700	3690	6580							
		93/ 189	380/ 222	0.8/ 1.3	15.35	-	-	3320				5360	SK 25 - 112M/4-2	46	42 - 43
		106/ 215	333/ 195	0.9/ 1.5	13.52	450	2220	3960				5760			
		119/ 241	297/ 174	1.0/ 1.7	12.03	1040	2560	4350				5930			
133/ 268		266/ 157	1.1/ 1.9	10.82	1540	2830	4240	5930							
147/ 297		240/ 141	1.2/ 2.1	9.77	1890	3040	4150	5880							
162/ 328		218/ 128	1.3/ 2.3	8.86	2200	3200	4050	5770							
177/ 359		200/ 117	1.3/ 2.3	8.09	2390	3270	3960	5700							
193/ 392		183/ 107	1.3/ 2.3	7.42	2590	3370	3870	5600							
210/ 426		168/ 99	1.3/ 2.3	6.82	2740	3430	3790	5480							
228/ 462		155/ 91	1.3/ 2.3	6.29	2750	3430	3710	5410							
247/ 499		143/ 84	1.3/ 2.3	5.82	2690	3410	3640	5300							
267/ 540		132/ 78	1.3/ 2.3	5.38	2640	3370	3560	5200							
287/ 581		123/ 72	1.3/ 2.3	5.00	2590	3330	3490	5090							
309/ 626		114/ 67	1.3/ 2.3	4.64	2540	3270	3420	4990							
331/ 671		107/ 63	1.3/ 2.3	4.33	2490	3200	3350	4850							
356/ 721		99/ 58	1.3/ 2.3	4.03	2450	3150	3290	4770							

1) bei / at / pour F_A = 0 N

2) bei / at / pour F_Q = 0 N



STIRNRADGETRIEBMOTOREN HELICAL GEARED MOTORS MOTOREDUCTEURS A ENGRENAGES CYLINDRIQUES

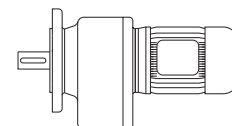

DREHSTROM, POLUMSCHALTBAR 1:2
THREE PHASE, POLE CHANGING 1:2
A COURANT TRIPHASE, A POLES COMMUTABLES 1:2

P _n [kW]	n ₂ [min ⁻¹]	M _a [Nm]		Standard f _B	i _{ges}	Normallagerung Normal bearing Roulement normal		Typenzusatz 5 Affix 5 Suffixe 5		Typ Type Type	ca. kg	Maße Dimens. Cotes
						F _{Q N} ¹⁾ [N]	F _{A N} ²⁾ [N]	F _Q ¹⁾ [N]	F _A ²⁾ [N]			
4.70 / 5.90	82/ 162	547/ 348	0.9/ 1.4	17.94	5490	7420	6090	10670	SK 33 - 132S/4-2	69	42 - 43	
	94/ 186	477/ 303	1.0/ 1.6	15.60	5360	7420	5920	10520				
	107/ 212	419/ 266	1.2/ 1.8	13.73	5210	7360	5750	10330				
	120/ 238	374/ 237	1.3/ 2.1	12.20	5090	7290	5600	10120				
	134/ 266	335/ 212	1.4/ 2.3	10.92	4960	7200	5450	9890				
	149/ 296	301/ 190	1.6/ 2.5	9.83	4830	7070	5310	9690				
	169/ 335	266/ 168	1.6/ 2.5	8.67	4710	7270	5160	9720				
	190/ 377	236/ 149	1.8/ 2.8	7.70	4570	7070	5010	9430				
	212/ 421	212/ 134	2.0/ 3.2	6.90	4450	6880	4860	9130				
	236/ 468	190/ 120	2.2/ 3.5	6.21	4320	6710	4720	8870				
	260/ 516	173/ 109	2.2/ 3.5	5.63	4210	6530	4590	8610				
	286/ 567	157/ 99	2.2/ 3.5	5.12	4110	6370	4470	8350				
	312/ 619	144/ 91	2.2/ 3.5	4.69	4000	6180	4370	8110				
	341/ 677	132/ 83	2.2/ 3.5	4.29	3900	6010	4250	7870				
	6.50 / 8.00	106/ 212	586/ 360	0.8/ 1.4	13.73	2540	4650	4780				8320
119/ 239		522/ 320	0.9/ 1.5	12.20	3250	5040	5210	8250				
133/ 267		467/ 286	1.0/ 1.7	10.92	3810	5310	5170	8240				
148/ 297		419/ 257	1.1/ 1.9	9.83	4280	5520	5040	8160				
167/ 336		372/ 227	1.1/ 1.9	8.67	4470	6000	4930	8440				
188/ 379		330/ 202	1.3/ 2.1	7.70	4360	5940	4800	8240				
210/ 422		296/ 181	1.4/ 2.3	6.90	4260	5870	4680	8070				
233/ 469		266/ 163	1.6/ 2.6	6.21	4150	5760	4550	7920				
258/ 518		241/ 147	1.6/ 2.6	5.63	4050	5690	4440	7720				
283/ 569		219/ 134	1.6/ 2.6	5.12	3960	5550	4330	7520				
309/ 622		201/ 123	1.6/ 2.6	4.69	3880	5430	4240	7320				
338/ 679		184/ 113	1.6/ 2.6	4.29	3780	5310	4130	7140				

1) bei / at / pour F_A = 0 N

2) bei / at / pour F_Q = 0 N

STIRNRADGETRIEBEMOTOREN HELICAL GEARED MOTORS MOTOREDUCTEURS A ENGRENAGES CYLINDRIQUES



ZWEISTUFIG
DOUBLE REDUCTION
A DEUX TRAINS D'ENGRENAGES

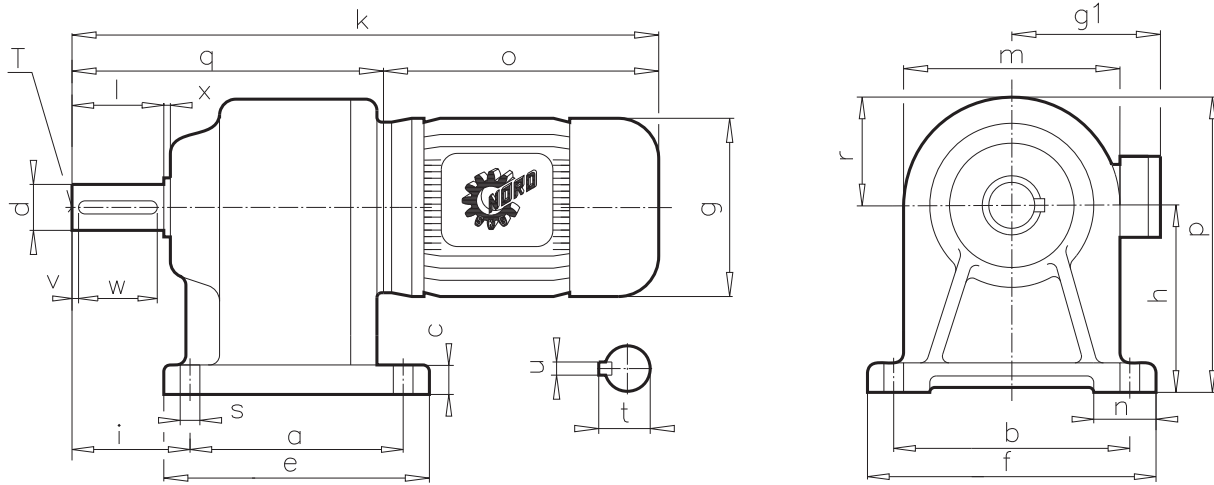

Typ Type Type	Befestigungsmaße (Fuß) Mounting dimensions (foot) Cotes de fixation (pattes)								Raum- und Anschlußmaße Outline dimensions Cotes d'encombrement								Wellenmaße Shaft dimensions Cotes arbre				
	a	b	c	e	f	n	s	g	g1	h	i	k	m	o	p	q	r	d	t	v	x
SK 0 - 63 S/L - 71 S/L - 80 S/L	50	110	12	78	130	20	8,5	130	110			330		192	151			16	18,0	4	2
								145	119	86	52	352	110	214	159	138	50,0				
									165	140			369		231	169			40	5	32
SK 01 - 63 S/L - 71 S/L - 80 S/L - 90 S/L	85	105	15	110	135	30	8,5	130	110			341		192	170			20	22,5	5	2
								145	119			363		214	175						
									165	140	102	68	380	135	231	183	149	67,5	40	6	30
								185	145			425		276	193						
SK 20 - 63 S/L - 71 S/L - 80 S/L - 90 S/L - 100 L	80	160	18	110	185	30	11	130	110			379		192	200			25	28,0	10	2
								145	119			401		214	200						
								165	140	125	74	418	150	231	206	187	75,0	60	8	40	M10
									185	145			463		276	216					
SK 25 - 80 S/L - 90 S/L - 100 L - 112 M	140	155	20	175	190	35	13	203	154			493		306	227						
								165	140			452		231	215			30	33,0	10	2
								185	145	130	115	497	170	276	221	221	85,0	70	8	50	M10
SK 30 - 80 S/L - 90 S/L - 100 L - 112 M	90	185	20	125	210	35	13	203	154			527		306	232						
								165	140			450		231	240			35	38,0	10	3
								185	145	155	86	495	170	276	246	219	85,0	70	10	50	M12
SK 33 - 90 S/L - 100 L - 112 M - 132 S/M	134	175	25	165	215	40	13	228	166			547		326	244						
								185	145			526		276	275			40	43,0	10	3
								203	154	175	120	556	200	306	277	250	100	80	12	60	M16
								228	166			576		326	289						
								266	194			661		411	308						
SK 01 V - 80 S/L	85	105	15	110	135	30	8,5	165	140	102	68	380	135	231	183	149	67,5	20	22,5	5	2
SK 20 V - 90 S/L	80	160	18	110	185	30	11	165	140			380		231	183			40	6	30	M6
SK 30 V - 90 S/L - 100 L	90	185	20	125	210	35	13	185	145	125	74	471	150	276	216	195	75,0	25	28,0	10	2
SK 33 V - 100 L - 112 M	134	175	25	165	215	40	13	185	145			501		276	240			60	8	40	M10
								203	154	155	86	531	170	306	257	225	85,0	35	38,0	10	3
								203	154			562		306	277			70	10	50	M12
								228	166	175	120	582	200	326	289	256	100	40	43,0	10	3
								228	166			582		326	289			80	12	60	M16

STIRNRADGETRIEBEMOTOREN HELICAL GEARED MOTORS MOTOREDUCTEURS A ENGRENAGES CYLINDRIQUES



ZWEISTUFIG
DOUBLE REDUCTION
A DEUX TRAINS D'ENGRENAGES

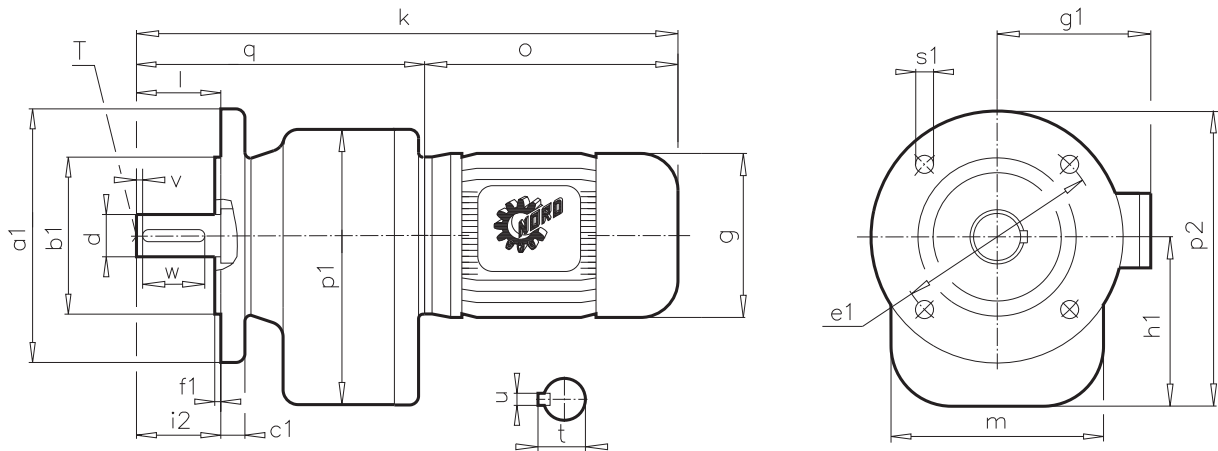

Typ Type Type	Befestigungsmaße (Flansch) * Mounting dimensions (flange) * Cotes de fixation (bride) *						Raum- und Anschlußmaße Outline dimensions Cotes d'encombrement									Wellenmaße Shaft dimensions Cotes arbre									
	a1	b1	c1	e1	f1	s1	g	g1	h1	i2	k	m	o	p1	p2	q	d	t	v	T					
																	l	u	w						
SK 0 F - 63 S/L - 71 S/L - 80 S/L	120	80	10	100	3,0	7	130	110			330		192	150			16	18,0	4	M 5					
							145	119	85	40	352	110	214	158	145	138									
							165	140			369		231	168									40	5	32
SK 01 F - 63 S/L - 71 S/L - 80 S/L - 90 S/L	140	95	10	115	3,0	9	130	110			341		192	166			20	22,5	5	M 6					
							145	119			363		214	171	168										
									98	40		135	231	179	178	149							40	6	30
SK 20 F - 63 S/L - 71 S/L - 80 S/L - 90 S/L - 100 L	160	110	10	130	3,5	9	130	110			379		192	198			25	28,0	10	M 10					
							145	119			401		214	198											
							165	140	123	60	418	150	231	204	203	187						60	8	40	
SK 25 F - 80 S/L - 90 S/L - 100 L - 112 M	160	110	12	130	3,5	9	130	110			452		231	213			30	33,0	10	M 10					
							145	119			497		276	219											
							165	140	128	70	527	170	306	230	208	221						70	8	50	
SK 30 F - 80 S/L - 90 S/L - 100 L - 112 M	200	130	12	165	3,5	11	130	110			450		231	238			35	38,0	10	M 12					
							145	119			495		276	244											
							165	140	153	70	525	170	306	255	253	219						70	10	50	
SK 33 F - 90 L - 100 L - 112 M - 132 S/M	250	180	16	215	4,0	14	130	110			526		276	273			40	43,0	10	M 16					
							145	119			556		306	275											
							185	145	173	80	576	200	326	287	298	250						80	12	60	
SK 01 VF - 80 S/L	140	95	10	115	3,0	9	165	140	98	40	380	135	231	183	168		20	22,5	5	M 6					
	160	110	10	130	3,5	9									178	149									
																		40	6	30					
SK 20 VF - 90 S	160	110	10	130	3,5	9	185	145	123	60	471	150	276	216	203	195		25	28,0	10	M 10				
																		60	8	40					
SK 30 VF - 90 S/L - 100 L	200	130	12	165	3,5	11	185	145	153	70	501	170	273	240	253	225		35	38,0	10	M 12				
																		70	10	50					
SK 33 VF - 100 L - 112 M	250	180	16	215	4,0	14	203	154	173	80	562	200	306	277	298	256		40	43,0	10	M 16				
																		80	12	60					

* Fettgedruckte Flanschmaße beziehen sich auf die Normalausführung.
Weitere Flansche siehe Seite 63.

* Bold typed dimensions refer to standard design.
Further flanges see page 63.

* Cotes imprimées en caractères gras se réfèrent à l'exécution normale.
D'autres brides voir page 63.

STIRNRADGETRIEBEMOTOREN HELICAL GEARED MOTORS MOTOREDUCTEURS A ENGRENAGES CYLINDRIQUES



DREISTUFIG
TRIPLE REDUCTION
A TROIS TRAINS D'ENGRENAGES

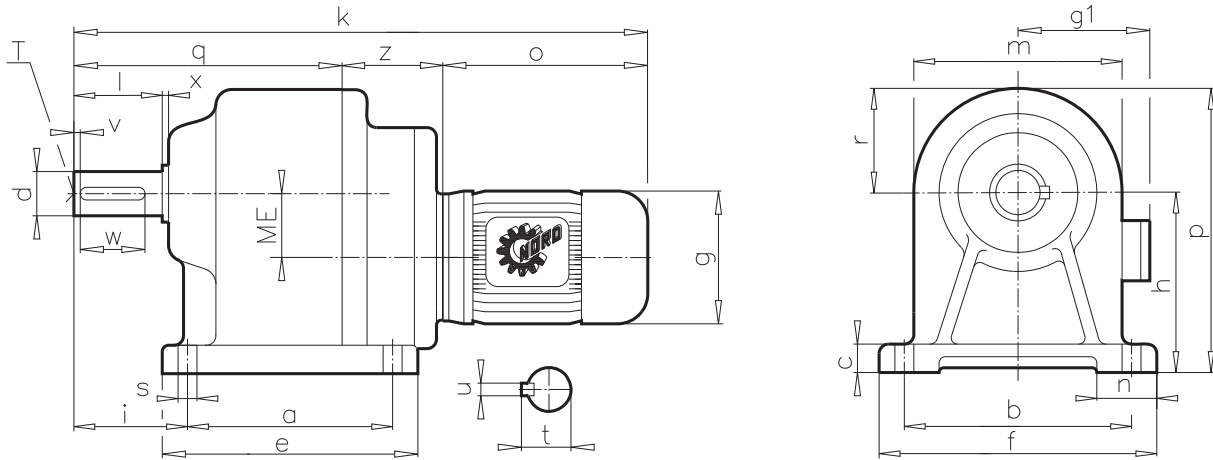

Typ Type Type	Befestigungsmaße (Fuß) Mounting dimensions (foot) Cotes de fixation (pattes)								Raum- und Anschlußmaße Outline dimensions Cotes d'encombrement											Wellenmaße Shaft dimensions Cotes arbre			
	a	b	c	e	f	n	s	g	g1	h	i	k	m	o	p	q	r	z	ME	d	t	v	x
																				l	u	w	T
SK 010 - 63 S/L	85	105	15	110	135	30	8,5	130	110	102	68	341	135	192	170	132	67,5	57	32	20	22,5	5	2
SK 200 - 63 S/L	80	160	18	110	185	30	11	130	110	125	74	429	150	192	200	172	75,0	65	32	25	28,0	10	2
SK 250 - 63 S/L - 71 S/L - 80 S	140	155	20	175	190	35	13	130 110 145 119 165 140			457 479 496	170	192 214 231	215	200	85,0	65	47	30 33,0 70 8	10 50	2 M10		
SK 300 - 63 S/L - 71 S/L - 80 S/L	90	185	20	125	210	35	13	130 110 145 119 165 140			455 477 494	170	192 214 231	240	198	85,0	65	47	35 38,0 70 10	10 50	3 M12		
SK 330 - 80 S/L - 90 S/L	134	175	25	165	215	40	13	165 140 185 145			535 580	200	231 276	275	223	100	81	65	40 43,0 80 12	10 60	3 M16		

STIRNRADGETRIEBEMOTOREN HELICAL GEARED MOTORS MOTOREDUCTEURS A ENGRENAGES CYLINDRIQUES



DREISTUFIG
TRIPLE REDUCTION
A TROIS TRAINS D'ENGRENAGES

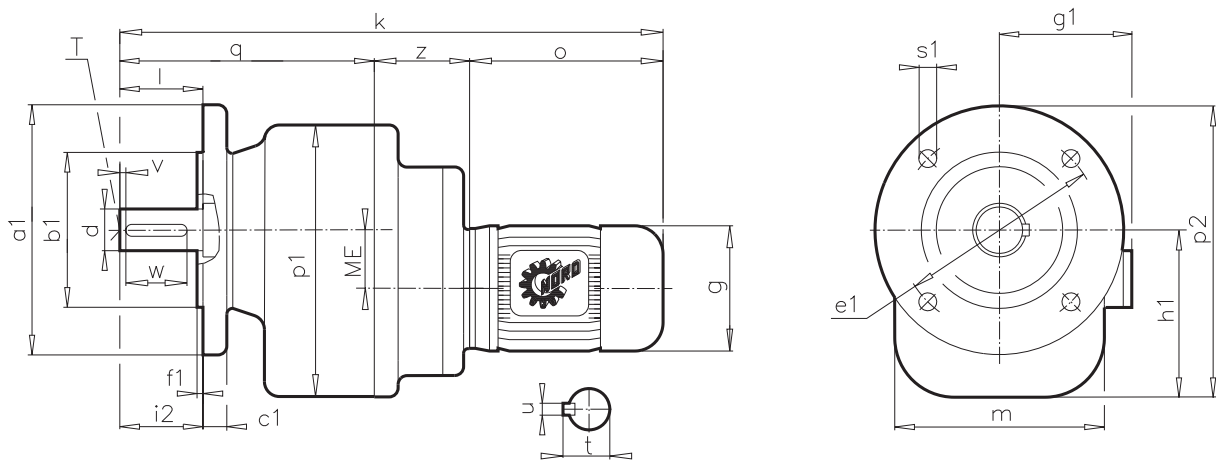

Typ Type Type	Befestigungsmaße (Flansch) * Mounting dimensions (flange) * Cotes de fixation (bride) *						Raum- und Anschlußmaße Outline dimensions Cotes d'encombrement											Wellenmaße Shaft dimensions Cotes arbre				
	a1	b1	c1	e1	f1	s1	g	g1	h1	i2	k	m	o	p1	p2	q	z	ME	d	t	v	T
							l	u	w													
SK 010 F - 63 S/	140	95	10	115	3,0	9													20	22,5	5	M6
	160	110	10	130	3,5	9	130	110	98	40	341	135	192	166	168	132	57	32	40	6	30	
SK 200 F - 63 S/L	160	110	10	130	3,5	9	130	110	123	60	429	150	192	198	203	172	65	32	25	28,0	10	M10
							60												60	8	40	
SK 250 F - 63 S/L - 71 S/L - 80 S							130	110			457		192						30	33,0	10	M10
	160	110	12	130	3,5	9	145	119	128	70	479	170	214	213	208	200	65	47	70	8	50	
							165	140			496		231									
SK 300 F - 63 S/L - 71 S/L - 80 S/L							130	110			455		192						35	38,0	10	M12
	200	130	12	165	3,5	11	145	119	153	70	477	170	214	238	253	198	65	47	70	10	50	
							165	140			494		231									
SK 330 F - 80 S/L - 90 S/L							165	140			535		231						40	43,0	10	M16
	250	180	16	215	4,0	14	185	145	173	80	580	200	276	273	298	223	81	65	80	12	60	

* Fettgedruckte Flanschmaße beziehen sich auf die Normalausführung.
Weitere Flansche siehe Seite 63.

* Bold typed dimensions refer to standard design.
Further flanges see page 63.

* Cotes imprimées en caractères gras se réfèrent à l'exécution normale.
D'autres brides voir page 63.

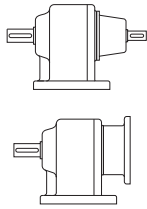

STIRNRADGETRIEBE HELICAL GEAR UNITS REDUCTEURS A ENGRENAGES CYLINDRIQUES



LEISTUNGS- UND ÜBERSETZUNGSTABELLE - TYP W UND TYP IEC
TABLE OF PERFORMANCES AND RATIOS - TYPE W AND TYPE IEC
TABLEAU DES PUISSANCES ET DES REDUCTIONS - TYPE W ET TYPE IEC

Typ	Übersetzung Ratio Réduction	Drehzahl Output speed Vitesse	M _{amax} Type W bei / at / pour	max. Antriebsleistung, Typ W bei max. input power, Type W at f _B ≥ 1 puissance d'entrée max., Type W pour				IEC -Motorbaugrößen und Normleistungen nach DIN 42677, f _B siehe Tabelle Seite 11 - 41					
Type								IEC motor frame sizes and rated powers according to DIN 42677, f _B see table page 11 - 41					
Type	i _{ges} i _{total} i _{totale}	4-pol / 50 Hz n ₂ [min ⁻¹]	4 - pol. [Nm]	4 - pol. (1400 min ⁻¹) [kW]	6 - pol. (930 min ⁻¹) [kW]	8 - pol. (700 min ⁻¹) [kW]	12 - pol. (450 min ⁻¹) [kW]	Tailles moteurs IEC et puissances nominales selon DIN 42677, f _B voir tab. page 11 - 41					
SK 0	70.98	20	50	0.10	0.07	0.05	0.03	63*	71*	-	-	-	-
	61.96	23	50	0.12	0.08	0.06	0.04	63*	71*	-	-	-	-
	54.46	26	50	0.14	0.09	0.07	0.04	63*	71*	-	-	-	-
	47.54	29	50	0.15	0.10	0.08	0.05	63*	71*	-	-	-	-
	42.01	33	50	0.17	0.11	0.09	0.06	63*	71*	-	-	-	-
	33.69	42	50	0.22	0.15	0.11	0.07	63	71*	-	-	-	-
	30.50	46	50	0.24	0.16	0.12	0.08	63	71*	-	-	-	-
	27.77	50	50	0.26	0.17	0.13	0.09	63	71*	-	-	-	-
	23.34	60	50	0.31	0.21	0.16	0.10	63	71*	-	-	-	-
	19.92	70	45	0.33	0.22	0.16	0.11	63	71*	-	-	-	-
	17.12	82	38	0.33	0.22	0.16	0.11	63	71*	-	-	-	-
	15.12	93	50	0.49	0.32	0.24	0.16	63	71	80*	-	-	-
	13.20	106	50	0.55	0.37	0.28	0.18	63	71	80*	-	-	-
	11.66	120	50	0.63	0.41	0.31	0.21	63	71	80*	-	-	-
	9.35	150	50	0.79	0.52	0.39	0.26	63	71	80	-	-	-
	8.47	165	50	0.86	0.57	0.43	0.29	63	71	80	-	-	-
7.71	182	50	0.95	0.63	0.48	0.31	63	71	80	-	-	-	
6.48	216	50	1.13	0.75	0.57	0.37	63	71	80	-	-	-	
5.53	253	50	1.32	0.87	0.66	0.44	63	71	80	-	-	-	
4.75	295	49	1.50	0.99	0.75	0.50	63	71	80	-	-	-	
4.46	314	50	1.50	0.99	0.75	0.50	63	71	80	-	-	-	
4.04	347	50	1.50	0.99	0.75	0.50	63	71	80	-	-	-	
3.68	380	50	1.50	0.99	0.75	0.50	63	71	80	-	-	-	
3.09	453	50	1.50	0.99	0.75	0.50	63	71	80	-	-	-	
2.64	530	50	1.50	0.99	0.75	0.50	63	71	80	-	-	-	
2.27	617	47	1.50	0.99	0.75	0.50	63	71	80	-	-	-	
SK 010	331.50	4.20	93	0.04	0.03	0.02	0.01	63*	71*	-	-	-	-
	289.00	4.80	100	0.05	0.03	0.03	0.02	63*	71*	-	-	-	-
	250.47	5.60	100	0.06	0.04	0.03	0.02	63*	71*	-	-	-	-
	221.00	6.30	100	0.07	0.04	0.03	0.02	63*	71*	-	-	-	-
	196.89	7.10	100	0.07	0.05	0.04	0.02	63*	71*	-	-	-	-
	176.80	7.90	100	0.08	0.05	0.04	0.03	63*	71*	-	-	-	-
	159.80	8.80	100	0.09	0.06	0.05	0.03	63*	71*	-	-	-	-
	145.23	9.60	100	0.10	0.07	0.05	0.03	63*	71*	-	-	-	-
	132.60	11	100	0.12	0.08	0.06	0.04	63*	71*	-	-	-	-
	121.55	12	100	0.13	0.08	0.06	0.04	63*	71*	-	-	-	-
	111.80	13	100	0.14	0.09	0.07	0.04	63*	71*	-	-	-	-
	103.13	14	95	0.14	0.09	0.07	0.05	63*	71*	-	-	-	-
	95.38	15	88	0.14	0.09	0.07	0.05	63*	71*	-	-	-	-
	88.40	16	79	0.13	0.09	0.07	0.04	63*	71*	-	-	-	-
	83.49	17	100	0.18	0.12	0.09	0.06	63*	71*	-	-	-	-
	73.67	19	100	0.20	0.13	0.10	0.07	63	71*	-	-	-	-
65.63	21	100	0.22	0.15	0.11	0.07	63	71*	-	-	-	-	
58.93	24	100	0.25	0.17	0.13	0.08	63	71*	-	-	-	-	
53.27	26	100	0.25	0.17	0.13	0.08	63	71*	-	-	-	-	
SK 01	111.61	13	93	0.13	0.08	0.06	0.04	63*	71*	-	-	-	-
	97.35	14	100	0.15	0.10	0.07	0.05	63*	71*	-	-	-	-
	85.85	16	89	0.15	0.10	0.07	0.05	63*	71*	-	-	-	-
	76.12	18	93	0.18	0.12	0.09	0.06	63*	71*	-	-	-	-
	66.40	21	100	0.22	0.15	0.11	0.07	63	71*	-	-	-	-
	58.50	24	93	0.23	0.15	0.12	0.08	63	71*	-	-	-	-
	51.03	27	100	0.28	0.19	0.14	0.09	63	71*	-	-	-	-
	45.00	31	100	0.32	0.21	0.16	0.11	63	71*	-	-	-	-
	40.05	35	100	0.37	0.24	0.18	0.12	63	71*	-	-	-	-
	36.00	39	100	0.41	0.27	0.20	0.13	63	71	-	-	-	-
	32.58	43	93	0.42	0.28	0.21	0.14	63	71	-	-	-	-
	29.61	47	84	0.41	0.27	0.21	0.14	63	71	-	-	-	-
	27.00	52	77	0.42	0.28	0.21	0.14	63	71	-	-	-	-
	24.75	57	70	0.42	0.28	0.21	0.14	63	71	-	-	-	-
	22.77	61	65	0.42	0.27	0.21	0.14	63	71	-	-	-	-
	20.97	67	60	0.42	0.28	0.21	0.14	63	71	-	-	-	-
19.44	72	55	0.41	0.27	0.21	0.14	63	71	-	-	-	-	
18.00	78	51	0.42	0.27	0.21	0.14	63	71	-	-	-	-	
16.90	83	93	0.81	0.53	0.40	0.27	63	71	80	90*	-	-	

* max. Antriebsleistung wie Typ W nach Tabelle

* max.input power as Type W acc.to table

* puissance d'entrée max. voir Type W voir tableau



STIRNRADGETRIEBE HELICAL GEAR UNITS REDUCTEURS A ENGRENAGES CYLINDRIQUES

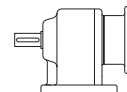
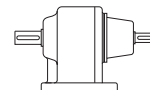

LEISTUNGS- UND ÜBERSETZUNGSTABELLE - TYP W UND TYP IEC
TABLE OF PERFORMANCES AND RATIOS - TYPE W AND TYPE IEC
TABLEAU DES PUISSANCES ET DES REDUCTIONS - TYPE W ET TYPE IEC

Typ	Übersetzung Ratio Réduction	Drehzahl Output speed Vitesse	M _{amax} Type W bei / at / pour	max. Antriebsleistung, Typ W bei max. input power, Type W at f _B ≥ 1 puissance d'entrée max., Type W pour				IEC -Motorbaugrößen und Normleistungen nach DIN 42677, f _B siehe Tabelle Seite 11 - 41								
Type								IEC motor frame sizes and rated powers according to DIN 42677, f _B see table page 11 - 41								
Type	i _{ges} i _{total} i _{totale}	4-pol / 50 Hz n ₂ [min ⁻¹]	4 - pol. [Nm]	4 - pol. (1400 min ⁻¹) [kW]	6 - pol. (930 min ⁻¹) [kW]	8 - pol. (700 min ⁻¹) [kW]	12 - pol. (450 min ⁻¹) [kW]	Tailles moteurs IEC et puissances nominales selon DIN 42677, f _B voir tab. page 11 - 41								
SK 01	16.74	84	48	0.42	0.28	0.21	0.14	63	71	-	-	-	-	-	-	
	15.57	90	44	0.41	0.27	0.21	0.14	63	71	-	-	-	-	-	-	
	14.74	95	100	0.99	0.66	0.50	0.33	63	71	80	90*	-	-	-	-	
	13.00	108	100	1.13	0.75	0.57	0.37	63	71	80	90*	-	-	-	-	
	11.57	121	100	1.27	0.84	0.63	0.42	63	71	80	90*	-	-	-	-	
	10.40	135	100	1.41	0.93	0.71	0.47	63	71	80	90*	-	-	-	-	
	9.41	149	100	1.50	0.99	0.75	0.50	63	71	80	90	-	-	-	-	
	8.55	164	100	1.50	0.99	0.75	0.50	63	71	80	90	-	-	-	-	
	7.80	179	100	1.50	0.99	0.75	0.50	63	71	80	90	-	-	-	-	
	7.15	196	100	1.50	0.99	0.75	0.50	63	71	80	90	-	-	-	-	
	IEC	6.58	213	99	1.50	0.99	0.75	0.50	63	71	80	90	-	-	-	-
		6.06	231	91	1.50	0.99	0.75	0.50	63	71	80	90	-	-	-	-
		5.62	249	85	1.50	0.99	0.75	0.50	63	71	80	90	-	-	-	-
		5.20	269	79	1.50	0.99	0.75	0.50	63	71	80	90	-	-	-	-
		4.84	289	73	1.50	0.99	0.75	0.50	63	71	80	90	-	-	-	-
		4.50	311	68	1.50	0.99	0.75	0.50	63	71	80	90	-	-	-	-
4.31		325	90	1.50	0.99	0.75	0.50	63	71	80	90	-	-	-	-	
3.93		356	82	1.50	0.99	0.75	0.50	63	71	80	90	-	-	-	-	
3.60		389	75	1.50	0.99	0.75	0.50	63	71	80	90	-	-	-	-	
3.31		423	69	1.50	0.99	0.75	0.50	63	71	80	90	-	-	-	-	
3.05		459	63	1.50	0.99	0.75	0.50	63	71	80	90	-	-	-	-	
2.83	495	59	1.50	0.99	0.75	0.50	63	71	80	90	-	-	-	-		
2.62	534	54	1.50	0.99	0.75	0.50	63	71	80	90	-	-	-	-		
2.44	574	51	1.50	0.99	0.75	0.50	63	71	80	90	-	-	-	-		
2.26	619	47	1.50	0.99	0.75	0.50	63	71	80	90	-	-	-	-		
SK 01 V	44.20	32	100	0.34	0.22	0.17	0.11	63	71*	80*	90*	-	-	-	-	
	39.00	36	100	0.38	0.25	0.19	0.12	63	71	80*	90*	-	-	-	-	
	34.75	40	100	0.42	0.28	0.21	0.14	63	71	80*	90*	-	-	-	-	
	31.20	45	100	0.47	0.31	0.24	0.16	63	71	80*	90*	-	-	-	-	
	28.24	50	100	0.52	0.35	0.26	0.17	63	71	80*	90*	-	-	-	-	
	25.66	55	100	0.58	0.38	0.29	0.19	63	71	80*	90*	-	-	-	-	
	23.40	60	100	0.63	0.41	0.31	0.21	63	71	80*	90*	-	-	-	-	
	21.45	65	100	0.68	0.45	0.34	0.22	63	71	80*	90*	-	-	-	-	
	19.73	71	93	0.69	0.46	0.35	0.23	63	71	80*	90*	-	-	-	-	
	18.17	77	86	0.69	0.46	0.35	0.23	63	71	80*	90*	-	-	-	-	
	16.85	83	79	0.69	0.45	0.34	0.23	63	71	80*	90*	-	-	-	-	
15.60	90	74	0.70	0.46	0.35	0.23	63	71	80*	90*	-	-	-	-		
14.49	97	68	0.69	0.46	0.35	0.23	63	71	80*	90*	-	-	-	-		
13.47	104	64	0.70	0.46	0.35	0.23	63	71	80*	90*	-	-	-	-		
SK 200	433.50	3.20	200	0.07	0.04	0.03	0.02	63*	71*	-	-	-	-	-	-	
	350.20	4.00	200	0.08	0.06	0.04	0.03	63*	71*	-	-	-	-	-	-	
	304.80	4.60	200	0.10	0.06	0.05	0.03	63*	71*	-	-	-	-	-	-	
	268.49	5.20	200	0.11	0.07	0.05	0.04	63*	71*	-	-	-	-	-	-	
	238.77	5.90	200	0.12	0.08	0.06	0.04	63*	71*	-	-	-	-	-	-	
	214.01	6.50	200	0.14	0.09	0.07	0.04	63*	71*	-	-	-	-	-	-	
	193.06	7.30	200	0.15	0.10	0.08	0.05	63*	71*	-	-	-	-	-	-	
	175.10	8.00	200	0.17	0.11	0.08	0.06	63*	71*	-	-	-	-	-	-	
	159.54	8.80	182	0.17	0.11	0.08	0.06	63*	71*	-	-	-	-	-	-	
	145.92	9.60	167	0.17	0.11	0.08	0.06	63*	71*	-	-	-	-	-	-	
	133.90	10	153	0.16	0.11	0.08	0.05	63*	71*	-	-	-	-	-	-	
	123.22	11	141	0.16	0.11	0.08	0.05	63*	71*	-	-	-	-	-	-	
	113.66	12	130	0.16	0.11	0.08	0.05	63*	71*	-	-	-	-	-	-	
	104.17	13	200	0.27	0.18	0.14	0.09	63	71*	-	-	-	-	-	-	
	91.75	15	200	0.31	0.21	0.16	0.10	63	71*	-	-	-	-	-	-	
	81.60	17	200	0.36	0.23	0.18	0.12	63	71*	-	-	-	-	-	-	
	73.14	19	196	0.37	0.24	0.19	0.12	63	71	-	-	-	-	-	-	
65.98	21	177	0.37	0.24	0.19	0.12	63	71	-	-	-	-	-	-		
59.84	23	160	0.37	0.24	0.19	0.12	63	71	-	-	-	-	-	-		
54.52	26	146	0.37	0.24	0.19	0.12	63	71	-	-	-	-	-	-		
SK 20	76.50	18	200	0.38	0.25	0.19	0.12	63	71	-	-	-	-	-	-	
	66.56	21	200	0.44	0.29	0.22	0.15	63	71	-	-	-	-	-	-	
	61.80	23	200	0.48	0.32	0.24	0.16	63	71	80*	90*	-	-	-	-	
	58.65	24	194	0.49	0.32	0.24	0.16	63	71	-	-	-	-	-	-	

* max. Antriebsleistung wie Typ W nach Tabelle

* max.input power as Type W acc.to table

* puissance d'entrée max. voir Type W voir tableau

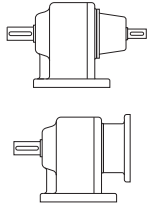

STIRNRADGETRIEBE HELICAL GEAR UNITS REDUCTEURS A ENGRENAGES CYLINDRIQUES



LEISTUNGS- UND ÜBERSETZUNGSTABELLE - TYP W UND TYP IEC
TABLE OF PERFORMANCES AND RATIOS - TYPE W AND TYPE IEC
TABLEAU DES PUISSANCES ET DES REDUCTIONS - TYPE W ET TYPE IEC

Typ	Übersetzung Ratio Réduction	Drehzahl Output speed Vitesse	M _{amax} Type W bei / at / pour	max. Antriebsleistung, Typ W bei max. input power, Type W at puissance d'entrée max., Type W pour				IEC -Motorbaugrößen und Normleistungen nach DIN 42677, f _B siehe Tabelle Seite 11 - 41								
Type								IEC motor frame sizes and rated powers according to DIN 42677, f _B see table page 11 - 41								
Type	i _{ges} i _{total} i _{totale}	4-pol / 50 Hz n ₂ [min ⁻¹]	4 - pol. [Nm]	4 - pol. (1400 min ⁻¹) [kW]	6 - pol. (930 min ⁻¹) [kW]	8 - pol. (700 min ⁻¹) [kW]	12 - pol. (450 min ⁻¹) [kW]	Tailles moteurs IEC et puissances nominales selon DIN 42677, f _B voir tab. page 11 - 41								
SK 20	53.77	26	200	0.54	0.36	0.27	0.18	63	71	80*	90*	-	-	-	-	
	47.38	30	200	0.63	0.41	0.31	0.21	63	71	80*	90*	-	-	-	-	
	42.13	33	200	0.69	0.46	0.35	0.23	63	71	80*	90*	-	-	-	-	
	37.80	37	200	0.77	0.51	0.39	0.26	63	71	80	90*	-	-	-	-	
	34.09	41	197	0.85	0.56	0.42	0.28	63	71	80	90*	-	-	-	-	
	30.90	45	179	0.84	0.56	0.42	0.28	63	71	80	90*	-	-	-	-	
	28.12	50	163	0.85	0.56	0.43	0.28	63	71	80	90*	-	-	-	-	
	25.75	54	149	0.84	0.56	0.42	0.28	63	71	80	90*	-	-	-	-	
	23.59	59	137	0.85	0.56	0.42	0.28	63	71	80	90*	-	-	-	-	
	IEC	21.73	64	126	0.84	0.56	0.42	0.28	63	71	80	90*	-	-	-	-
		21.12	66	187	1.29	0.85	0.65	0.43	63	71	80	90*	-	-	-	-
		20.09	70	116	0.85	0.56	0.43	0.28	63	71	80	90*	-	-	-	-
		18.54	76	107	0.85	0.56	0.43	0.28	63	71	80	90*	-	-	-	-
		18.37	76	184	1.46	0.97	0.73	0.48	63	71	80	90*	-	-	-	-
		16.19	86	183	1.65	1.09	0.82	0.54	63	71	80	90	-	-	-	-
		14.40	97	182	1.85	1.22	0.92	0.61	63	71	80	90	-	-	-	-
		12.92	108	182	2.06	1.36	1.03	0.68	63	71	80	90	-	-	-	-
		11.65	120	180	2.20	1.45	1.10	0.73	63	71	80	90	-	-	-	-
		10.56	133	164	2.20	1.45	1.10	0.73	63	71	80	90	-	-	-	-
		9.61	146	149	2.20	1.45	1.10	0.73	63	71	80	90	-	-	-	-
		8.80	159	136	2.20	1.45	1.10	0.73	63	71	80	90	-	-	-	-
		8.06	174	125	2.20	1.45	1.10	0.73	63	71	80	90	-	-	-	-
		7.43	188	115	2.20	1.45	1.10	0.73	63	71	80	90	-	-	-	-
		6.86	204	106	2.20	1.45	1.10	0.73	63	71	80	90	-	-	-	-
		6.58	213	133	2.20	1.45	1.10	0.73	63	71	80	90	-	-	-	-
		6.34	221	98	2.20	1.45	1.10	0.73	63	71	80	90	-	-	-	-
		5.80	241	133	2.20	1.45	1.10	0.73	63	71	80	90	-	-	-	-
5.15	272	122	2.20	1.45	1.10	0.73	63	71	80	90	-	-	-	-		
4.62	303	110	2.20	1.45	1.10	0.73	63	71	80	90	-	-	-	-		
4.17	336	99	2.20	1.45	1.10	0.73	63	71	80	90	-	-	-	-		
3.78	370	90	2.20	1.45	1.10	0.73	63	71	80	90	-	-	-	-		
3.44	407	82	2.20	1.45	1.10	0.73	63	71	80	90	-	-	-	-		
3.15	444	75	2.20	1.45	1.10	0.73	63	71	80	90	-	-	-	-		
2.89	484	68	2.20	1.45	1.10	0.73	63	71	80	90	-	-	-	-		
2.66	526	63	2.20	1.45	1.10	0.73	63	71	80	90	-	-	-	-		
2.46	569	58	2.20	1.45	1.10	0.73	63	71	80	90	-	-	-	-		
2.27	617	54	2.20	1.45	1.10	0.73	63	71	80	90	-	-	-	-		
SK 20 V	41.76	34	200	0.71	0.47	0.36	0.23	-	-	80*	90*	-	-	-	-	
	36.80	38	200	0.80	0.53	0.40	0.26	-	-	80*	90*	-	-	-	-	
	32.72	43	200	0.90	0.59	0.45	0.30	-	-	80*	90*	-	-	-	-	
	30.90	45	200	0.94	0.62	0.47	0.31	-	-	80*	90*	-	-	-	-	
	29.33	48	200	1.01	0.66	0.50	0.33	-	-	80*	90*	-	-	-	-	
	27.23	51	200	1.07	0.70	0.53	0.35	-	-	80*	90*	-	-	-	-	
	26.46	53	200	1.11	0.73	0.55	0.37	-	-	80*	90*	-	-	-	-	
	24.21	58	200	1.21	0.80	0.61	0.40	-	-	80*	90*	-	-	-	-	
	21.73	64	200	1.34	0.88	0.67	0.44	-	-	80*	90*	-	-	-	-	
	21.12	66	187	1.29	0.85	0.65	0.43	-	-	-	-	-	-	-	-	
	20.00	70	178	1.30	0.86	0.65	0.43	-	-	80*	90*	-	-	-	-	
	19.60	71	200	1.49	0.98	0.74	0.49	-	-	80*	90*	-	-	-	-	
	18.37	76	184	1.46	0.97	0.73	0.48	-	-	-	-	-	-	-	-	
	16.19	86	183	1.65	1.09	0.82	0.54	-	-	-	-	-	-	-	-	
	14.40	97	182	1.85	1.22	0.92	0.61	-	-	-	-	-	-	-	-	
	12.92	108	182	2.06	1.36	1.03	0.68	-	-	-	-	-	-	-	-	
	11.65	120	180	2.20	1.45	1.10	0.73	-	-	-	-	-	-	-	-	
	10.56	133	164	2.20	1.45	1.10	0.73	-	-	-	-	-	-	-	-	
	9.61	146	149	2.20	1.45	1.10	0.73	-	-	-	-	-	-	-	-	
	8.80	159	136	2.20	1.45	1.10	0.73	-	-	-	-	-	-	-	-	
	8.06	174	125	2.20	1.45	1.10	0.73	-	-	-	-	-	-	-	-	
7.43	188	115	2.20	1.45	1.10	0.73	-	-	-	-	-	-	-	-		
6.86	204	106	2.20	1.45	1.10	0.73	-	-	-	-	-	-	-	-		
6.58	213	133	2.20	1.45	1.10	0.73	-	-	-	-	-	-	-	-		
6.34	221	98	2.20	1.45	1.10	0.73	-	-	-	-	-	-	-	-		
5.80	241	133	2.20	1.45	1.10	0.73	-	-	-	-	-	-	-	-		
5.15	272	122	2.20	1.45	1.10	0.73	-	-	-	-	-	-	-	-		

* max. Antriebsleistung wie Typ W nach Tabelle

* max.input power as Type W acc.to table

* puissance d'entrée max. voir Type W voir tableau



STIRNRADGETRIEBE HELICAL GEAR UNITS REDUCTEURS A ENGRENAGES CYLINDRIQUES

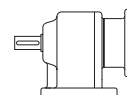
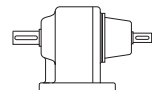

LEISTUNGS- UND ÜBERSETZUNGSTABELLE - TYP W UND TYP IEC
TABLE OF PERFORMANCES AND RATIOS - TYPE W AND TYPE IEC
TABLEAU DES PUISSANCES ET DES REDUCTIONS - TYPE W ET TYPE IEC

Typ	Übersetzung Ratio Réduction	Drehzahl Output speed Vitesse	M _{amax} Type W bei / at / pour	max. Antriebsleistung, Typ W bei max. input power, Type W at $f_b \geq 1$ puissance d'entrée max., Type W pour				IEC -Motorbaugrößen und Normleistungen nach DIN 42677, f_b siehe Tabelle Seite 11 - 41					
				4 - pol. [Nm]	4 - pol. (1400 min ⁻¹) [kW]	6 - pol. (930 min ⁻¹) [kW]	8 - pol. (700 min ⁻¹) [kW]	12 - pol. (450 min ⁻¹) [kW]	IEC motor frame sizes and rated powers according to DIN 42677, f_b see table page 11 - 41				
Type	i_{ges} i_{total} i_{totale}	4-pol / 50 Hz n_2 [min ⁻¹]	4 - pol. [Nm]	4 - pol. (1400 min ⁻¹) [kW]	6 - pol. (930 min ⁻¹) [kW]	8 - pol. (700 min ⁻¹) [kW]	12 - pol. (450 min ⁻¹) [kW]	Tailles moteurs IEC et puissances nominales selon DIN 42677, f_b voir tab. page 11 - 41					
SK 20 V	4.62 4.17	303 336	110 99	2.20 2.20	1.45 1.45	1.10 1.10	0.73 0.73	-	-	-	-	-	-
W	3.78	370	90	2.20	1.45	1.10	0.73	-	-	-	-	-	-
+	3.44	407	82	2.20	1.45	1.10	0.73	-	-	-	-	-	-
IEC	3.15	444	75	2.20	1.45	1.10	0.73	-	-	-	-	-	-
	2.89	484	68	2.20	1.45	1.10	0.73	-	-	-	-	-	-
	2.66	526	63	2.20	1.45	1.10	0.73	-	-	-	-	-	-
	2.46	569	58	2.20	1.45	1.10	0.73	-	-	-	-	-	-
	2.27	617	54	2.20	1.45	1.10	0.73	-	-	-	-	-	-
SK 250	488.07	2.90	251	0.08	0.05	0.04	0.03	63*	71*	-	-	-	-
	425.34	3.30	300	0.10	0.07	0.05	0.03	63*	71*	-	-	-	-
W	374.85	3.70	300	0.12	0.08	0.06	0.04	63*	71*	-	-	-	-
	357.73	3.90	254	0.10	0.07	0.05	0.03	63*	71*	-	-	-	-
+	333.54	4.20	300	0.13	0.09	0.07	0.04	63*	71*	-	-	-	-
	311.75	4.50	300	0.14	0.09	0.07	0.05	63*	71*	-	-	-	-
IEC	274.74	5.10	300	0.16	0.11	0.08	0.05	63*	71*	-	-	-	-
	244.47	5.70	300	0.18	0.12	0.09	0.06	63	71*	-	-	-	-
	219.79	6.40	300	0.20	0.13	0.10	0.07	63	71*	-	-	-	-
	198.49	7.10	300	0.22	0.15	0.11	0.07	63	71*	-	-	-	-
	179.98	7.80	300	0.25	0.16	0.12	0.08	63	71*	-	-	-	-
	164.29	8.50	300	0.27	0.18	0.13	0.09	63	71*	-	-	-	-
	150.83	9.30	281	0.27	0.18	0.14	0.09	63	71*	-	-	-	-
	138.49	10	258	0.27	0.18	0.14	0.09	63	71*	-	-	-	-
	127.84	11	239	0.28	0.18	0.14	0.09	63	71*	-	-	-	-
	122.88	11	314	0.36	0.24	0.18	0.12	63	71	80*	90*	-	-
	108.29	13	300	0.41	0.27	0.20	0.13	63	71	80*	90*	-	-
	96.36	15	300	0.47	0.31	0.24	0.16	63	71	80*	90*	-	-
	90.06	16	300	0.50	0.33	0.25	0.17	63	71	80*	90*	-	-
	79.37	18	300	0.57	0.37	0.28	0.19	63	71	80*	90*	-	-
	70.62	20	300	0.63	0.41	0.31	0.21	63	71	80*	90*	-	-
	63.50	22	300	0.69	0.46	0.35	0.23	63	71	80*	90*	-	-
	57.34	24	300	0.75	0.50	0.38	0.25	63	71	80	90*	-	-
SK 25	54.23	26	253	0.69	0.45	0.34	0.23	-	-	80*	90*	-	-
	47.26	30	300	0.94	0.62	0.47	0.31	-	-	80	90*	-	-
	41.65	34	300	1.07	0.70	0.53	0.35	-	-	80	90*	-	-
W	37.06	38	300	1.19	0.79	0.60	0.39	-	-	80	90*	-	-
	33.32	42	293	1.29	0.85	0.64	0.43	-	-	80	90*	-	-
+	30.53	46	300	1.45	0.95	0.72	0.48	-	-	80	90*	-	-
	27.16	52	300	1.63	1.08	0.82	0.54	-	-	80	90	-	-
IEC	24.42	57	300	1.79	1.18	0.90	0.59	-	-	80	90	-	-
	22.05	63	300	1.98	1.31	0.99	0.65	-	-	80	90	-	-
	20.00	70	300	2.20	1.45	1.10	0.73	-	-	80	90	-	-
	18.27	77	274	2.21	1.46	1.10	0.73	-	-	80	90	-	-
	17.61	80	251	2.10	1.39	1.05	0.69	-	-	80	90	100*	112*
	16.75	84	251	2.21	1.46	1.10	0.73	-	-	80	90	-	-
	15.35	91	300	2.86	1.89	1.43	0.94	-	-	80	90	100*	112*
	13.52	104	300	3.27	2.16	1.63	1.08	-	-	80	90	100	112*
	12.03	116	300	3.64	2.41	1.82	1.20	-	-	80	90	100	112*
	10.82	129	300	4.00	2.64	2.00	1.32	-	-	80	90	100	112
	9.77	143	300	4.00	2.64	2.00	1.32	-	-	80	90	100	112
	8.86	158	291	4.00	2.64	2.00	1.32	-	-	80	90	100	112
	8.09	173	266	4.00	2.64	2.00	1.32	-	-	80	90	100	112
	7.42	189	244	4.00	2.64	2.00	1.32	-	-	80	90	100	112
	6.82	205	224	4.00	2.64	2.00	1.32	-	-	80	90	100	112
	6.29	223	207	4.00	2.64	2.00	1.32	-	-	80	90	100	112
	5.82	241	192	4.00	2.64	2.00	1.32	-	-	80	90	100	112
	5.38	260	177	4.00	2.64	2.00	1.32	-	-	80	90	100	112
	5.00	280	164	4.00	2.64	2.00	1.32	-	-	80	90	100	112
	4.64	302	153	4.00	2.64	2.00	1.32	-	-	80	90	100	112
	4.33	323	143	4.00	2.64	2.00	1.32	-	-	80	90	100	112
	4.03	347	133	4.00	2.64	2.00	1.32	-	-	80	90	100	112
	3.75	373	123	4.00	2.64	2.00	1.32	-	-	80	90	100	112
	3.48	402	155	4.00	2.64	2.00	1.32	-	-	80	90	100	112
	3.21	436	143	4.00	2.64	2.00	1.32	-	-	80	90	100	112

* max. Antriebsleistung wie Typ W nach Tabelle

* max.input power as Type W acc.to table

* puissance d'entrée max. voir Type W voir tableau

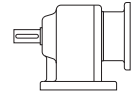
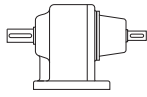

**STIRNRADGETRIEBE
HELICAL GEAR UNITS
REDUCTEURS A ENGRENAGES CYLINDRIQUES**



**LEISTUNGS- UND ÜBERSETZUNGSTABELLE - TYP W UND TYP IEC
TABLE OF PERFORMANCES AND RATIOS - TYPE W AND TYPE IEC
TABLEAU DES PUISSANCES ET DES REDUCTIONS - TYPE W ET TYPE IEC**

Typ	Übersetzung Ratio Réduction	Drehzahl Output speed Vitesse	M _{amax} Type W bei / at / pour	max. Antriebsleistung, Typ W bei max. input power, Type W at f _B ≥ 1 puissance d'entrée max., Type W pour				IEC -Motorbaugrößen und Normleistungen nach DIN 42677, f _B siehe Tabelle Seite 11 - 41								
Type								IEC motor frame sizes and rated powers according to DIN 42677, f _B see table page 11 - 41								
Type	i _{ges} i _{total} i _{totale}	4-pol / 50 Hz n ₂ [min ⁻¹]	4 - pol. [Nm]	4 - pol. (1400 min ⁻¹) [kW]	6 - pol. (930 min ⁻¹) [kW]	8 - pol. (700 min ⁻¹) [kW]	12 - pol. (450 min ⁻¹) [kW]	Tailles moteurs IEC et puissances nominales selon DIN 42677, f _B voir tab. page 11 - 41								
SK 25	2.98	470	133	4.00	2.64	2.00	1.32	-	-	80	90	100	112	-	-	
	2.75	509	123	4.00	2.64	2.00	1.32	-	-	80	90	100	112	-	-	
	W	5.55	252	114	3.01	1.99	1.50	0.99	-	-	80	90	100	112	-	-
	+	2.37	591	106	4.00	2.64	2.00	1.32	-	-	80	90	100	112	-	-
	IEC	2.21	633	99	4.00	2.64	2.00	1.32	-	-	80	90	100	112	-	-
		2.06	680	92	4.00	2.64	2.00	1.32	-	-	80	90	100	112	-	-
	1.92	729	86	4.00	2.64	2.00	1.32	-	-	80	90	100	112	-	-	
SK 300	484.62	2.90	389	0.12	0.08	0.06	0.04	63*	71*	-	-	-	-	-	-	
	429.23	3.30	400	0.14	0.09	0.07	0.05	63*	71*	-	-	-	-	-	-	
	383.92	3.60	400	0.15	0.10	0.08	0.05	63*	71*	-	-	-	-	-	-	
	376.15	3.70	335	0.13	0.09	0.06	0.04	63*	71*	-	-	-	-	-	-	
	W	314.20	4.50	400	0.19	0.12	0.09	0.06	63	71*	-	-	-	-	-	-
	286.81	4.90	396	0.20	0.13	0.10	0.07	63	71*	-	-	-	-	-	-	
	+	263.08	5.30	400	0.22	0.15	0.11	0.07	63	71*	-	-	-	-	-	-
	242.31	5.80	400	0.24	0.16	0.12	0.08	63	71*	-	-	-	-	-	-	
	IEC	223.98	6.30	400	0.26	0.17	0.13	0.09	63	71*	-	-	-	-	-	-
	207.69	6.70	388	0.27	0.18	0.14	0.09	63	71*	-	-	-	-	-	-	
	193.12	7.20	361	0.27	0.18	0.14	0.09	63	71*	-	-	-	-	-	-	
	180.00	7.80	337	0.28	0.18	0.14	0.09	63	71*	-	-	-	-	-	-	
	169.39	8.30	400	0.35	0.23	0.17	0.11	63	71*	-	-	-	-	-	-	
	151.51	9.20	400	0.39	0.25	0.19	0.13	63	71	-	-	-	-	-	-	
	136.61	10	335	0.35	0.23	0.18	0.12	63	71*	-	-	-	-	-	-	
	124.00	11	400	0.46	0.30	0.23	0.15	63	71	80*	90*	-	-	-	-	
	110.91	13	400	0.54	0.36	0.27	0.18	63	71	80*	90*	-	-	-	-	
	100.00	14	335	0.49	0.32	0.25	0.16	63	71	80*	90*	-	-	-	-	
	90.77	15	400	0.63	0.41	0.31	0.21	63	71	80*	90*	-	-	-	-	
	82.86	17	396	0.70	0.47	0.35	0.23	63	71	80*	90*	-	-	-	-	
	76.00	18	400	0.75	0.50	0.38	0.25	63	71	80	90*	-	-	-	-	
	70.00	20	400	0.75	0.50	0.38	0.25	63	71	80	90*	-	-	-	-	
64.71	22	400	0.75	0.50	0.38	0.25	63	71	80	90*	-	-	-	-		
SK 30	72.10	19	386	0.77	0.51	0.38	0.25	80	90*	-	-	-	-	-	-	
	63.86	22	400	0.92	0.61	0.46	0.30	80	90*	-	-	-	-	-	-	
	57.17	24	400	1.01	0.66	0.50	0.33	80	90*	-	-	-	-	-	-	
	51.50	27	335	0.95	0.63	0.47	0.31	80	90*	-	-	-	-	-	-	
	W	47.68	29	400	1.21	0.80	0.61	0.40	80	90*	-	-	-	-	-	-
	42.68	33	400	1.38	0.91	0.69	0.46	80	90*	-	-	-	-	-	-	
	+	38.45	36	335	1.26	0.83	0.63	0.42	80	90*	-	-	-	-	-	-
	34.91	40	400	1.68	1.11	0.84	0.55	80	90	-	-	-	-	-	-	
	IEC	31.84	44	396	1.82	1.20	0.91	0.60	80	90	-	-	-	-	-	-
	29.22	48	400	2.01	1.33	1.01	0.66	80	90	-	-	-	-	-	-	
	26.92	52	400	2.18	1.44	1.09	0.72	80	90	-	-	-	-	-	-	
	24.89	56	368	2.16	1.42	1.08	0.71	80	90	-	-	-	-	-	-	
	23.08	61	341	2.18	1.44	1.09	0.72	80	90	-	-	-	-	-	-	
	21.46	65	317	2.16	1.42	1.08	0.71	80	90	-	-	-	-	-	-	
	21.28	66	384	2.65	1.75	1.33	0.88	80	90	100*	112*	-	-	-	-	
	20.00	70	295	2.16	1.43	1.08	0.71	80	90	-	-	-	-	-	-	
	18.85	74	394	3.05	2.01	1.53	1.01	80	90	100	112*	-	-	-	-	
	16.87	83	389	3.38	2.23	1.69	1.12	80	90	100	112*	-	-	-	-	
	15.20	92	335	3.23	2.13	1.61	1.06	80	90	100	112*	-	-	-	-	
	13.80	101	379	4.00	2.64	2.00	1.32	80	90	100	112	-	-	-	-	
	12.59	111	374	4.00	2.64	2.00	1.32	80	90	100	112	-	-	-	-	
	11.55	121	370	4.00	2.64	2.00	1.32	80	90	100	112	-	-	-	-	
	10.64	132	366	4.00	2.64	2.00	1.32	80	90	100	112	-	-	-	-	
	9.85	142	353	4.00	2.64	2.00	1.32	80	90	100	112	-	-	-	-	
	9.12	154	326	4.00	2.64	2.00	1.32	80	90	100	112	-	-	-	-	
	8.48	165	304	4.00	2.64	2.00	1.32	80	90	100	112	-	-	-	-	
	7.90	177	283	4.00	2.64	2.00	1.32	80	90	100	112	-	-	-	-	
	7.02	199	289	4.00	2.64	2.00	1.32	80	90	100	112	-	-	-	-	
	6.27	223	287	4.00	2.64	2.00	1.32	80	90	100	112	-	-	-	-	
	5.65	248	284	4.00	2.64	2.00	1.32	80	90	100	112	-	-	-	-	
	5.13	273	270	4.00	2.64	2.00	1.32	80	90	100	112	-	-	-	-	
	4.68	299	247	4.00	2.64	2.00	1.32	80	90	100	112	-	-	-	-	

* max. Antriebsleistung wie Typ W nach Tabelle

* max.input power as Type W acc.to table

* puissance d'entrée max. voir Type W voir tableau



STIRNRADGETRIEBE HELICAL GEAR UNITS REDUCTEURS A ENGRENAGES CYLINDRIQUES

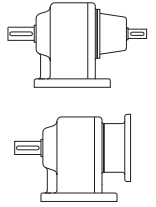

LEISTUNGS- UND ÜBERSETZUNGSTABELLE - TYP W UND TYP IEC
TABLE OF PERFORMANCES AND RATIOS - TYPE W AND TYPE IEC
TABLEAU DES PUISSANCES ET DES REDUCTIONS - TYPE W ET TYPE IEC

Typ	Übersetzung Ratio Réduction	Drehzahl Output speed Vitesse	M _{amax} Type W bei / at / pour	max. Antriebsleistung, Typ W bei max. input power, Type W at $f_b \geq 1$ puissance d'entrée max., Type W pour				IEC - Motorbaugrößen und Normleistungen nach DIN 42677, f_b siehe Tabelle Seite 11 - 41								
Type								IEC motor frame sizes and rated powers according to DIN 42677, f_b see table page 11 - 41								
Type	i_{ges} i_{total} i_{totale}	4-pol / 50 Hz n_2 [min ⁻¹]	4 - pol. [Nm]	4 - pol. (1400 min ⁻¹) [kW]	6 - pol. (930 min ⁻¹) [kW]	8 - pol. (700 min ⁻¹) [kW]	12 - pol. (450 min ⁻¹) [kW]	Tailles moteurs IEC et puissances nominales selon DIN 42677, f_b voir tab. page 11 - 41								
SK 30	4.29	326	226	4.00	2.64	2.00	1.32	80	90	100	112	-	-	-	-	
	3.96	354	208	4.00	2.64	2.00	1.32	80	90	100	112	-	-	-	-	
	3.66	383	193	4.00	2.64	2.00	1.32	80	90	100	112	-	-	-	-	
	3.39	413	179	4.00	2.64	2.00	1.32	80	90	100	112	-	-	-	-	
	3.15	444	166	4.00	2.64	2.00	1.32	80	90	100	112	-	-	-	-	
	2.94	476	155	4.00	2.64	2.00	1.32	80	90	100	112	-	-	-	-	
SK 30 V	51.46	27	400	1.13	0.75	0.57	0.37	-	-	-	90*	100*	112*	-	-	
	46.07	30	400	1.26	0.83	0.63	0.41	-	-	-	90*	100*	112*	-	-	
	41.50	34	335	1.19	0.79	0.60	0.39	-	-	-	90*	100*	112*	-	-	
	37.68	37	400	1.55	1.02	0.77	0.51	-	-	-	90	100*	112*	-	-	
	W	34.39	41	396	1.70	1.12	0.85	0.56	-	-	-	90	100*	112*	-	-
		31.54	44	400	1.84	1.22	0.92	0.61	-	-	-	90	100*	112*	-	-
		29.05	48	400	2.01	1.33	1.01	0.66	-	-	-	90	100*	112*	-	-
	IEC	26.89	52	400	2.18	1.44	1.09	0.72	-	-	-	90	100*	112*	-	-
		24.90	56	390	2.29	1.51	1.14	0.75	-	-	-	90	100*	112*	-	-
		23.16	60	363	2.28	1.51	1.14	0.75	-	-	-	90	100*	112*	-	-
		21.58	65	338	2.30	1.52	1.15	0.76	-	-	-	90	100*	112*	-	-
		21.28	66	384	2.65	1.75	1.33	0.88	-	-	-	-	-	-	-	-
		18.85	74	394	3.05	2.01	1.53	1.01	-	-	-	-	-	-	-	-
		16.87	83	389	3.38	2.23	1.69	1.12	-	-	-	-	-	-	-	-
		15.20	92	335	3.23	2.13	1.61	1.06	-	-	-	-	-	-	-	-
		13.80	101	379	4.00	2.64	2.00	1.32	-	-	-	-	-	-	-	-
		12.59	111	374	4.00	2.64	2.00	1.32	-	-	-	-	-	-	-	-
		11.55	121	370	4.00	2.64	2.00	1.32	-	-	-	-	-	-	-	-
		10.64	132	366	4.00	2.64	2.00	1.32	-	-	-	-	-	-	-	-
		9.85	142	353	4.00	2.64	2.00	1.32	-	-	-	-	-	-	-	-
		9.12	154	326	4.00	2.64	2.00	1.32	-	-	-	-	-	-	-	-
		8.48	165	304	4.00	2.64	2.00	1.32	-	-	-	-	-	-	-	-
		7.90	177	283	4.00	2.64	2.00	1.32	-	-	-	-	-	-	-	-
		7.02	199	289	4.00	2.64	2.00	1.32	-	-	-	-	-	-	-	-
	6.27	223	287	4.00	2.64	2.00	1.32	-	-	-	-	-	-	-	-	
	5.65	248	284	4.00	2.64	2.00	1.32	-	-	-	-	-	-	-	-	
	5.13	273	270	4.00	2.64	2.00	1.32	-	-	-	-	-	-	-	-	
	4.68	299	247	4.00	2.64	2.00	1.32	-	-	-	-	-	-	-	-	
4.29	326	226	4.00	2.64	2.00	1.32	-	-	-	-	-	-	-	-		
3.96	354	208	4.00	2.64	2.00	1.32	-	-	-	-	-	-	-	-		
3.66	383	193	4.00	2.64	2.00	1.32	-	-	-	-	-	-	-	-		
3.39	413	179	4.00	2.64	2.00	1.32	-	-	-	-	-	-	-	-		
3.15	444	166	4.00	2.64	2.00	1.32	-	-	-	-	-	-	-	-		
2.94	476	155	4.00	2.64	2.00	1.32	-	-	-	-	-	-	-	-		
SK 330	364.80	3.80	674	0.27	0.18	0.13	0.09	80*	90*	-	-	-	-	-	-	
	317.12	4.40	700	0.32	0.21	0.16	0.11	80*	90*	-	-	-	-	-	-	
	279.06	5.00	700	0.37	0.24	0.18	0.12	80*	90*	-	-	-	-	-	-	
	247.93	5.60	700	0.41	0.27	0.21	0.14	80*	90*	-	-	-	-	-	-	
	W	225.58	6.20	700	0.45	0.30	0.23	0.15	80*	90*	-	-	-	-	-	-
		198.51	7.10	700	0.52	0.34	0.26	0.17	80*	90*	-	-	-	-	-	-
		176.36	7.90	659	0.55	0.36	0.27	0.18	80*	90*	-	-	-	-	-	-
	IEC	157.90	8.90	589	0.55	0.36	0.27	0.18	80*	90*	-	-	-	-	-	-
		142.29	9.80	531	0.54	0.36	0.27	0.18	80*	90*	-	-	-	-	-	-
		128.90	11	482	0.56	0.37	0.28	0.18	80*	90*	-	-	-	-	-	-
		117.30	12	438	0.55	0.36	0.28	0.18	80*	90*	-	-	-	-	-	-
		107.15	13	401	0.55	0.36	0.27	0.18	80*	90*	-	-	-	-	-	-
		98.19	14	367	0.54	0.36	0.27	0.18	80*	90*	-	-	-	-	-	-
		89.63	16	700	1.17	0.77	0.59	0.39	80	90*	-	-	-	-	-	-
		79.63	18	700	1.32	0.87	0.66	0.44	80	90*	-	-	-	-	-	-
		71.29	20	700	1.47	0.97	0.73	0.48	80	90*	-	-	-	-	-	-
		64.24	22	700	1.50	0.99	0.75	0.50	80	90	-	-	-	-	-	-
58.20	24	700	1.50	0.99	0.75	0.50	80	90	-	-	-	-	-	-		
52.96	26	700	1.50	0.99	0.75	0.50	80	90	-	-	-	-	-	-		
SK 33	55.78	25	671	1.76	1.16	0.88	0.58	90	100*	112*	-	-	-	-	-	
	48.50	29	700	2.13	1.40	1.06	0.70	90	100*	112*	-	-	-	-	-	
	42.68	33	700	2.42	1.60	1.21	0.80	90	100*	112*	-	-	-	-	-	
	37.93	37	651	2.52	1.66	1.26	0.83	90	100*	112*	-	-	-	-	-	

* max. Antriebsleistung wie Typ W nach Tabelle

* max. input power as Type W acc. to table

* puissance d'entrée max. voir Type W voir tableau

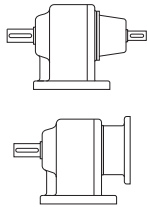

STIRNRADGETRIEBE HELICAL GEAR UNITS REDUCTEURS A ENGRENAGES CYLINDRIQUES



LEISTUNGS- UND ÜBERSETZUNGSTABELLE - TYP W UND TYP IEC
TABLE OF PERFORMANCES AND RATIOS - TYPE W AND TYPE IEC
TABLEAU DES PUISSANCES ET DES REDUCTIONS - TYPE W ET TYPE IEC

Typ	Übersetzung Ratio Réduction	Drehzahl Output speed Vitesse	M _{amax} Type W bei / at / pour	max. Antriebsleistung, Typ W bei f _B ≥ 1 max. input power, Type W at f _B ≥ 1 puissance d'entrée max., Type W pour				IEC -Motorbaugrößen und Normleistungen nach DIN 42677, f _B siehe Tabelle Seite 11 - 41								
								IEC motor frame sizes and rated powers according to DIN 42677, f _B see table page 11 - 41								
Type	i _{ges} i _{total} i _{totale}	4-pol / 50 Hz n ₂ [min ⁻¹]	4 - pol. [Nm]	4 - pol. (1400 min ⁻¹) [kW]	6 - pol. (930 min ⁻¹) [kW]	8 - pol. (700 min ⁻¹) [kW]	12 - pol. (450 min ⁻¹) [kW]	Tailles moteurs IEC et puissances nominales selon DIN 42677, f _B voir tab. page 11 - 41								
SK 33	33.95	41	582	2.50	1.65	1.25	0.82	90	100*	112*	-	-	-	-	-	-
	30.56	46	524	2.52	1.67	1.26	0.83	90	100*	112*	-	-	-	-	-	-
	27.74	50	476	2.49	1.64	1.25	0.82	90	100*	112*	-	-	-	-	-	-
	25.22	56	433	2.54	1.68	1.27	0.84	90	100*	112*	-	-	-	-	-	-
	23.09	61	396	2.53	1.67	1.26	0.83	90	100*	112*	-	-	-	-	-	-
	21.15	66	363	2.51	1.66	1.25	0.83	90	100*	112*	-	-	-	-	-	-
	19.40	72	333	2.51	1.66	1.26	0.83	90	100*	112*	-	-	-	-	-	-
	17.94	78	497	4.06	2.68	2.03	1.34	90	100	112	132*	-	-	-	-	-
	17.87	78	306	2.50	1.65	1.25	0.82	90	100*	112*	-	-	-	-	-	-
	16.49	85	283	2.52	1.66	1.26	0.83	90	100*	112*	-	-	-	-	-	-
	15.60	90	489	4.61	3.04	2.30	1.52	90	100	112	132*	-	-	-	-	-
	13.73	102	488	5.21	3.44	2.61	1.72	90	100	112	132*	-	-	-	-	-
	12.20	115	487	5.86	3.87	2.93	1.94	90	100	112	132*	-	-	-	-	-
	10.92	128	484	6.49	4.28	3.24	2.14	90	100	112	132*	-	-	-	-	-
	9.83	142	481	7.15	4.72	3.58	2.36	90	100	112	132*	-	-	-	-	-
	8.67	161	423	7.13	4.71	3.57	2.35	90	100	112	132*	-	-	-	-	-
	7.70	182	423	7.50	4.95	3.75	2.48	90	100	112	132	-	-	-	-	-
	6.90	203	422	7.50	4.95	3.75	2.48	90	100	112	132	-	-	-	-	-
	6.21	225	422	7.50	4.95	3.75	2.48	90	100	112	132	-	-	-	-	-
	5.63	249	383	7.50	4.95	3.75	2.48	90	100	112	132	-	-	-	-	-
	5.12	273	348	7.50	4.95	3.75	2.48	90	100	112	132	-	-	-	-	-
	4.69	299	319	7.50	4.95	3.75	2.48	90	100	112	132	-	-	-	-	-
	4.29	326	292	7.50	4.95	3.75	2.48	90	100	112	132	-	-	-	-	-
	3.94	355	268	7.50	4.95	3.75	2.48	90	100	112	132	-	-	-	-	-
	3.62	387	246	7.50	4.95	3.75	2.48	90	100	112	132	-	-	-	-	-
	3.35	418	228	7.50	4.95	3.75	2.48	90	100	112	132	-	-	-	-	-
	3.20	438	257	7.50	4.95	3.75	2.48	90	100	112	132	-	-	-	-	-
	2.93	478	235	7.50	4.95	3.75	2.48	90	100	112	132	-	-	-	-	-
	2.68	522	215	7.50	4.95	3.75	2.48	90	100	112	132	-	-	-	-	-
	2.46	569	198	7.50	4.95	3.75	2.48	90	100	112	132	-	-	-	-	-
	2.26	619	182	7.50	4.95	3.75	2.48	90	100	112	132	-	-	-	-	-
2.09	670	168	7.50	4.95	3.75	2.48	90	100	112	132	-	-	-	-	-	
SK 33 V	34.50	41	658	2.82	1.86	1.41	0.93	-	-	100*	112*	132*	-	-	-	
	30.36	46	656	3.16	2.09	1.58	1.04	-	-	100*	112*	132*	-	-	-	
	26.98	52	583	3.17	2.10	1.59	1.05	-	-	100*	112*	132*	-	-	-	
	24.15	58	522	3.17	2.09	1.59	1.05	-	-	100*	112*	132*	-	-	-	
	21.74	64	470	3.15	2.08	1.57	1.04	-	-	100*	112*	132*	-	-	-	
	19.73	71	427	3.17	2.10	1.59	1.05	-	-	100*	112*	132*	-	-	-	
	17.94	78	388	3.17	2.09	1.58	1.05	-	-	100*	112*	132*	-	-	-	
	16.42	85	355	3.16	2.09	1.58	1.04	-	-	100*	112*	132*	-	-	-	
	15.60	90	489	4.00	2.64	2.00	1.32	-	-	-	-	-	-	-	-	
	13.73	102	488	4.00	2.64	2.00	1.32	-	-	-	-	-	-	-	-	
	12.20	115	487	4.00	2.64	2.00	1.32	-	-	-	-	-	-	-	-	
	10.92	128	484	4.00	2.64	2.00	1.32	-	-	-	-	-	-	-	-	
	9.83	142	481	4.00	2.64	2.00	1.32	-	-	-	-	-	-	-	-	
	8.67	161	423	4.00	2.64	2.00	1.32	-	-	-	-	-	-	-	-	
	7.70	182	423	4.00	2.64	2.00	1.32	-	-	-	-	-	-	-	-	
	6.90	203	422	4.00	2.64	2.00	1.32	-	-	-	-	-	-	-	-	
	6.21	225	422	4.00	2.64	2.00	1.32	-	-	-	-	-	-	-	-	
	5.63	249	383	4.00	2.64	2.00	1.32	-	-	-	-	-	-	-	-	
	5.12	273	348	4.00	2.64	2.00	1.32	-	-	-	-	-	-	-	-	
	4.69	299	319	4.00	2.64	2.00	1.32	-	-	-	-	-	-	-	-	
	4.29	326	292	4.00	2.64	2.00	1.32	-	-	-	-	-	-	-	-	
	3.94	355	268	4.00	2.64	2.00	1.32	-	-	-	-	-	-	-	-	
	3.62	387	246	4.00	2.64	2.00	1.32	-	-	-	-	-	-	-	-	
3.35	418	228	4.00	2.64	2.00	1.32	-	-	-	-	-	-	-	-		
3.20	438	257	4.00	2.64	2.00	1.32	-	-	-	-	-	-	-	-		
2.93	478	235	4.00	2.64	2.00	1.32	-	-	-	-	-	-	-	-		
2.68	522	215	4.00	2.64	2.00	1.32	-	-	-	-	-	-	-	-		
2.46	569	198	4.00	2.64	2.00	1.32	-	-	-	-	-	-	-	-		
2.26	619	182	4.00	2.64	2.00	1.32	-	-	-	-	-	-	-	-		
2.09	670	168	4.00	2.64	2.00	1.32	-	-	-	-	-	-	-	-		

* max. Antriebsleistung wie Typ W nach Tabelle

* max.input power as Type W acc.to table

* puissance d'entrée max. voir Type W voir tableau

**NOTIZEN
NOTES
NOTES**

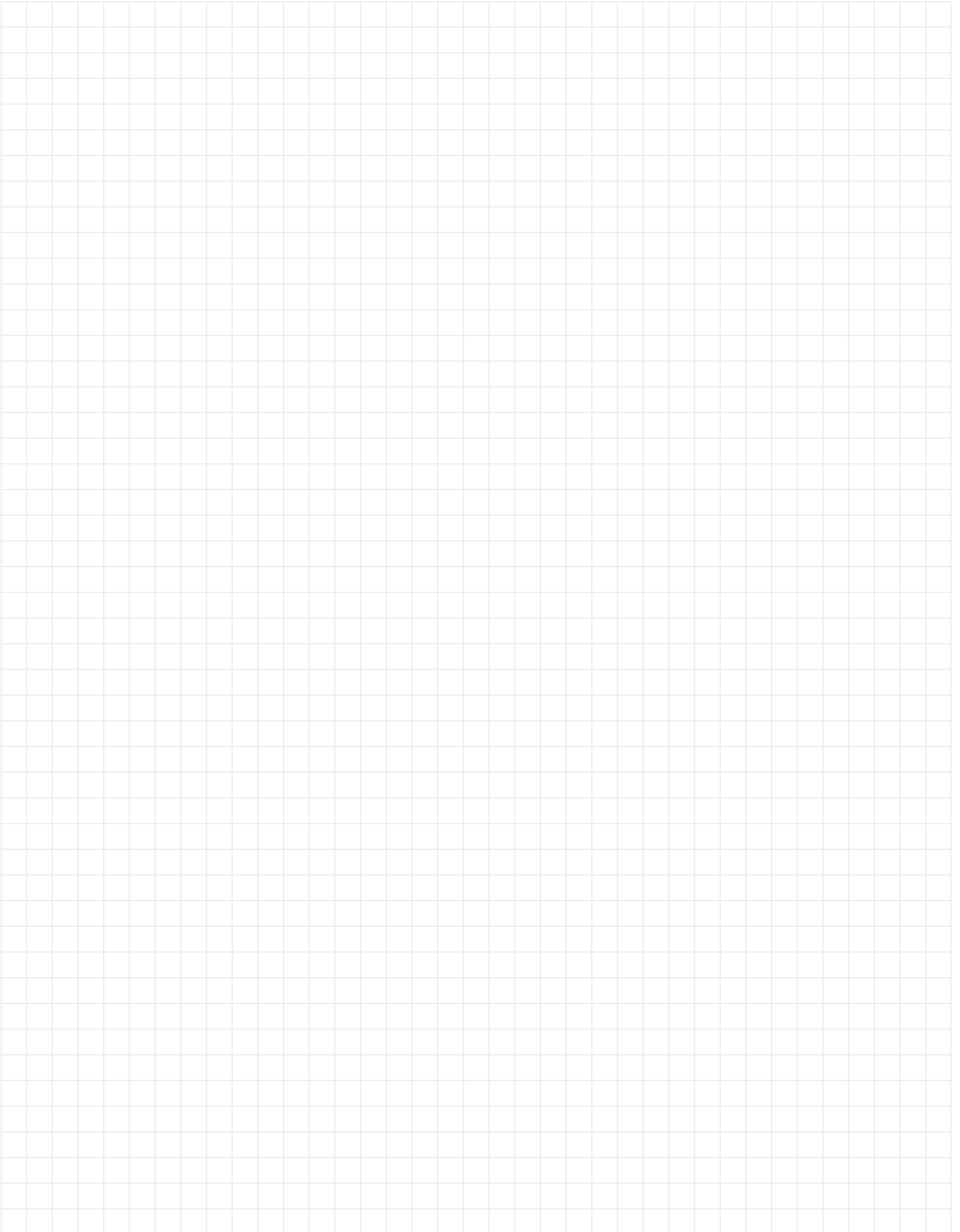

STIRNRADGETRIEBE HELICAL GEAR UNITS REDUCTEURS A ENGRENAGES CYLINDRIQUES



MIT FREIER ANTRIEBSWELLE - TYP W , ZWEISTUFIG
WITH FREE INPUT SHAFT - TYPE W , DOUBLE REDUCTION
AVEC ARBRE D'ENTREE LIBRE - TYPE W , A DEUX TRAINS D'ENGRENAGES

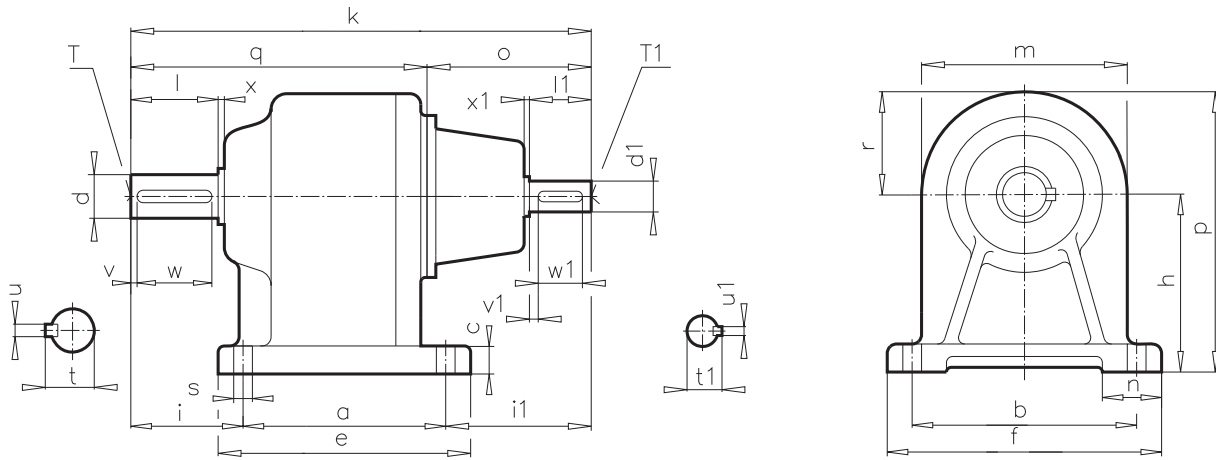

Typ Type Type	Befestigungsmaße (Fuß) Mounting dimensions (foot) Cotes de fixation (pattes)								Raum- und Anschlußmaße Outline dimensions Cotes d'encombrement								Wellenmaße / Shaft dimensions / Cotes arbre Abtriebswelle Output shaft Arbre de sortie				Antriebswelle Input shaft Arbre d'entrée			
	a	b	c	e	f	n	s	h	i	i1	k	m	o	p	q	r	d	t	v	x	d1	t1	v1	x1
																	l	u	w	T	l1	u1	w1	T1
SK 0 - W	50	110	12	78	130	20	8,5	86	52	143	245	110	107	136	138	50,0	16	18,0	4	2	16	18,0	4	2
																	40	5	32	M5	40	5	32	M5
SK 01 - W	85	105	15	110	135	30	8,5	102	68	103	256	135	107	170	149	67,5	20	22,5	5	2	16	18,0	4	2
																	40	6	30	M6	40	5	32	M5
SK 20 - W	80	160	18	110	185	30	11	125	74	140	294	150	107	200	187	75,0	25	28,0	10	2	16	18,0	4	2
																	60	8	40	M10	40	5	32	M5
SK 25 - W	140	155	20	175	190	35	13	130	115	87	342	170	121	215	221	85,0	30	33,0	10	2	24	27,0	5	2
																	70	8	50	M10	50	8	40	M8
SK 30 - W	90	185	20	125	210	35	13	155	86	164	340	170	121	240	219	85,0	35	38,0	10	3	24	27,0	5	2
																	70	10	50	M12	50	8	40	M8
SK 33 - W	134	175	25	165	215	40	13	175	120	121	375	200	125	275	250	100	40	43,0	10	3	24	27,0	5	2
																	80	12	60	M16	50	8	40	M8
SK 01 V - W	85	105	15	110	135	30	8,5	102	68	103	256	135	107	170	149	67,5	20	22,5	5	2	16	18,0	4	2
																	40	6	30	M6	40	5	32	M5
SK 20 V - W	80	160	18	110	185	30	11	125	74	162	316	150	121	200	195	75,0	25	28,0	10	2	24	27,0	5	2
																	60	8	40	M10	50	8	40	M8
SK 30 V - W	90	185	20	125	210	35	13	155	86	174	350	170	125	240	225	85,0	35	38,0	10	3	24	27,0	5	2
																	70	10	50	M12	50	8	40	M8
SK 33 V - W	134	175	25	165	215	40	13	175	120	183	437	200	181	275	256	100	40	43,0	10	3	32	35,0	7	2
																	80	12	60	M16	70	10	56	M12

STIRNRADGETRIEBE HELICAL GEAR UNITS REDUCTEURS A ENGRENAGES CYLINDRIQUES



MIT FREIER ANTRIEBSWELLE - TYP W , ZWEISTUFIG
WITH FREE INPUT SHAFT - TYPE W , DOUBLE REDUCTION
AVEC ARBRE D'ENTREE LIBRE - TYPE W , A DEUX TRAINS D'ENGRENAGES

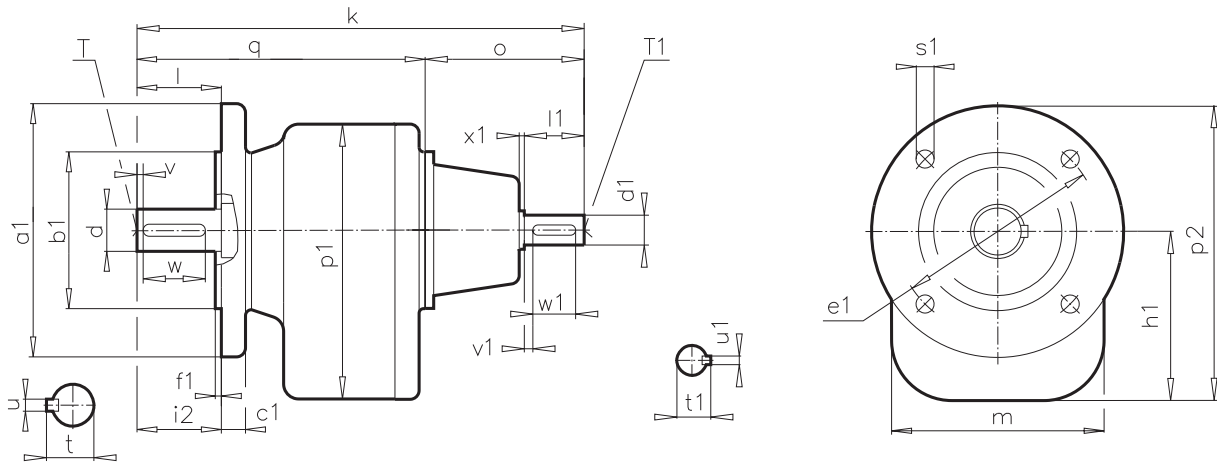

Typ Type Type	Befestigungsmaße (Flansch) * Mounting dimensions (flange) * Cotes de fixation (bride) *						Raum- und Anschlußmaße Outline dimensions Cotes d'encombrement							Wellenmaße / Shaft dimensions / Cotes arbre Abtriebswelle Output shaft Arbre de sortie				Antriebswelle Input shaft Arbre d'entrée				
	a1	b1	c1	e1	f1	s1	h1	i2	k	m	o	p1	p2	q	d	t	v	T	d1	t1	v1	x1
															l	u	w		l1	u1	w1	T1
SK 0 F - W	120	80	10	100	3,0	7	85	40	245	110	107	135	145	138	16	18,0	4	M 5	16	18,0	4	2
													168	149	40	5	32		40	5	32	M 5
SK 01 F - W	140	95	10	115	3,0	9	98	40	256	135	107	166			20	22,5	5	M 6	16	18,0	4	2
	160	110	10	130	3,5	9							178	149	40	6	30		40	5	32	M 5
SK 20 F - W	160	110	10	130	3,5	9	123	60	294	150	107	198	203	187	25	28,0	10	M 10	16	18,0	4	2
															60	8	40		40	5	32	M 5
SK 25 F - W	160	110	12	130	3,5	9	128	70	342	170	121	213	208	221	30	33,0	10	M 10	24	27,0	5	2
															70	8	50		50	8	40	M 8
SK 30 F - W	200	130	12	165	3,5	11	153	70	340	170	121	238	253	219	35	38,0	10	M 12	24	27,0	5	2
															70	10	50		50	8	40	M 8
SK 33 F - W	250	180	16	215	4,0	14	173	80	375	200	125	273	298	250	40	43,0	10	M 16	24	27,0	5	2
															80	12	60		50	8	40	M 8
SK 01 VF - W	140	95	10	115	3,0	9	98	40	256	135	107	166		168	20	22,5	5	M 6	16	18,0	4	2
	160	110	10	130	3,5	9							178	149	40	6	30		40	5	32	M 5
SK 20 VF - W	160	110	10	130	3,5	9	123	60	316	150	121	198	203	195	25	28,0	10	M 10	24	27,0	5	2
															60	8	40		50	8	40	M 8
SK 30 VF - W	200	130	12	165	3,5	11	153	70	350	170	125	238	253	225	35	38,0	10	M 12	24	27,0	5	2
															70	10	50		50	8	40	M 8
SK 33 VF - W	250	180	16	215	4,0	14	173	80	437	200	181	273	298	256	40	43,0	10	M 16	32	35,0	7	2
															80	12	60		70	10	56	M 12

* Fettgedruckte Flanschmaße beziehen sich auf die Normalausführung.
Weitere Flansche siehe Seite 63.

* Bold typed dimensions refer to standard design.
Further flanges see page 63.

* Cotes imprimées en caractères gras se réfèrent à l'exécution normale
D'autres brides voir page 63.

**STIRNRADGETRIEBE
HELICAL GEAR UNITS
REDUCTEURS A ENGRENAGES CYLINDRIQUES**



MIT FREIER ANTRIEBSWELLE - TYP W , DREISTUFIG
WITH FREE INPUT SHAFT - TYPE W , TRIPLE REDUCTION
AVEC ARBRE D'ENTREE LIBRE - TYPE W , A TROIS TRAINS D'ENGRENAGES

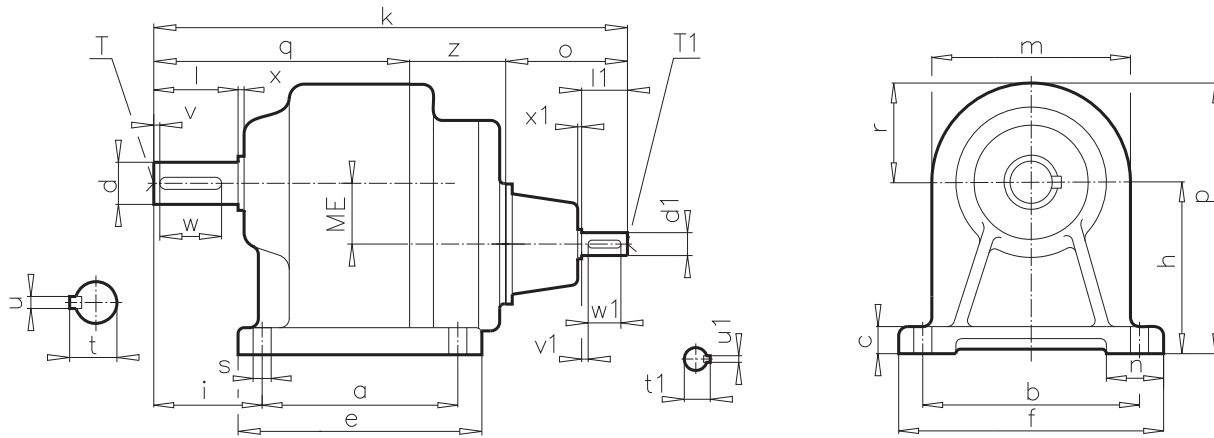

Typ Type Type	Befestigungsmaße (Fuß) Mounting dimensions (foot) Cotes de fixation (pattes)							Raum- und Anschlußmaße Outline dimensions Cotes d'encombrement							Wellenmaße / Shaft dimensions / Cotes arbre				Abtriebswelle Output shaft Arbre de sortie				Antriebswelle Input shaft Arbre d'entrée										
	a	b	c	e	f	n	s	h	i	k	m	o	p	q	r	z	ME	d	t	v	x	d1	t1	v1	x1	l	u	w	T	l1	u1	w1	T1
SK 010 - W	85	105	15	110	135	30	8,5	102	68	296	135	107	170	132	67,5	57	32	20	22,5	5	2	16	18,0	4	2	40	6	30	M6	40	5	32	M5
SK 200 - W	80	160	18	110	185	30	11	125	74	344	150	107	200	172	75,0	65	32	25	28,0	10	2	16	18,0	4	2	60	8	40	M10	40	5	32	M5
SK 250 - W	140	155	20	175	190	35	13	130	115	372	170	107	215	200	85,0	65	47	30	33,0	10	2	16	18,0	4	2	70	8	50	M10	40	5	32	M5
SK 300 - W	90	185	20	125	210	35	13	155	86	370	170	107	240	198	85,0	65	47	35	38,0	10	3	16	18,0	4	2	70	10	50	M12	40	5	32	M5
SK 330 - W	134	175	25	165	215	40	13	175	120	425	200	121	275	223	100	81	65	40	43,0	10	3	24	27,0	5	2	80	12	60	M16	50	8	40	M8

STIRNRADGETRIEBE HELICAL GEAR UNITS REDUCTEURS A ENGRENAGES CYLINDRIQUES



MIT FREIER ANTRIEBSWELLE - TYP W , DREISTUFIG
WITH FREE INPUT SHAFT - TYPE W , TRIPLE REDUCTION
AVEC ARBRE D'ENTREE LIBRE - TYPE W , A TROIS TRAINS D'ENGRENAGES

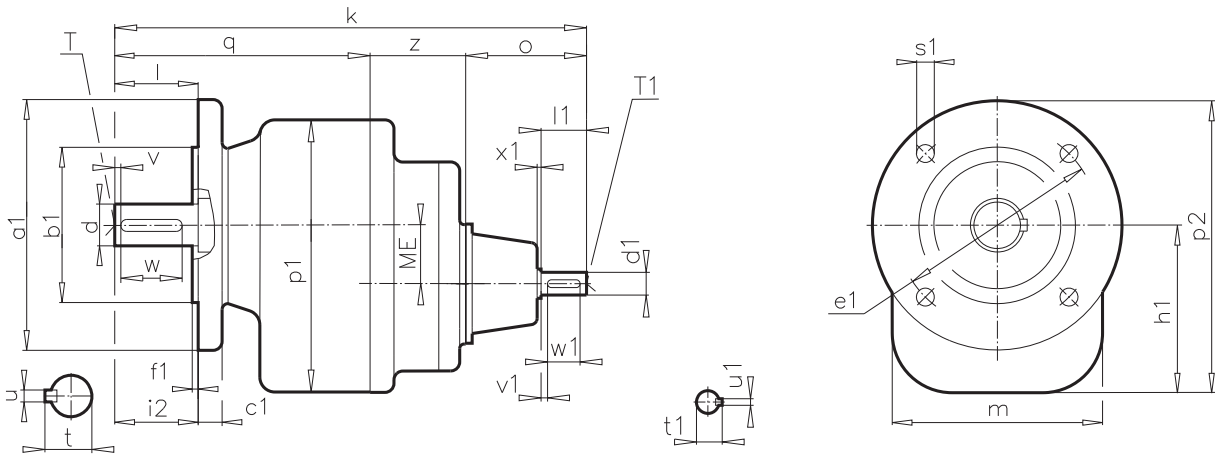

Typ Type Type	Befestigungsmaße (Flansch) * Mounting dimensions (flange) * Cotes de fixation (bride) *						Raum- und Anschlußmaße Outline dimensions Cotes d'encombrement										Wellenmaße / Shaft dimensions / Cotes arbre Abtriebswelle Output shaft Arbre de sortie				Antriebswelle Input shaft Arbre d'entrée			
	a1	b1	c1	e1	f1	s1	h1	i2	k	m	o	p1	p2	q	z	ME	d	t	v	T	d1	t1	v1	x1
																	l	u	w		l1	u1	w1	T1
SK 010 F - W	140	95	10	115	3,0	9							168				20	22,5	5	M6	16	18,0	4	2
	160	110	10	130	3,5	9	98	40	296	135	107	166		132	57	32	40	6	30		40	5	32	M5
SK 200 F - W	160	110	10	130	3,5	9	123	60	344	150	107	198	203	172	65	32	25	28,0	10	M10	16	18,0	4	2
																	60	8	40		40	5	32	M5
SK 250 F - W	160	110	12	130	3,5	9	128	70	372	170	107	213	208	200	65	47	30	33,0	10	M10	16	18,0	4	2
																	70	8	50		40	5	32	M5
SK 300 F - W	200	130	12	165	3,5	11	153	70	370	170	107	238	253	198	65	47	35	38,0	10	M12	16	18,0	4	2
																	70	10	50		40	5	32	M5
SK 330 F - W	250	180	16	215	4,0	14	173	80	425	200	121	273	298	223	81	65	40	43,0	10	M16	24	27,0	5	2
																	80	12	60		50	8	40	M8

* Fettgedruckte Flanschmaße beziehen sich auf die Normalausführung.
Weitere Flansche siehe Seite 63.

* Bold typed dimensions refer to standard design.
Further flanges see page 63.

* Cotes imprimées en caractères gras se réfèrent à l'exécution normale.
D'autres brides voir page 63.

STIRNRADGETRIEBE HELICAL GEAR UNITS REDUCTEURS A ENGRENAGES CYLINDRIQUES



ZUM ANFLANSCHEN VON IEC-NORMMOTOREN NACH DIN 42677 - TYP IEC , ZWEISTUFIG
FOR ASSEMBLY WITH IEC STANDARD MOTORS ACC: TO DIN 42677 - TYPE IEC , DOUBLE REDUCTION
POUR MONTAGE MOTEURS NORME SELON DIN 42677 - TYPE IEC , A DEUX TRAINS D'ENGRENAGES

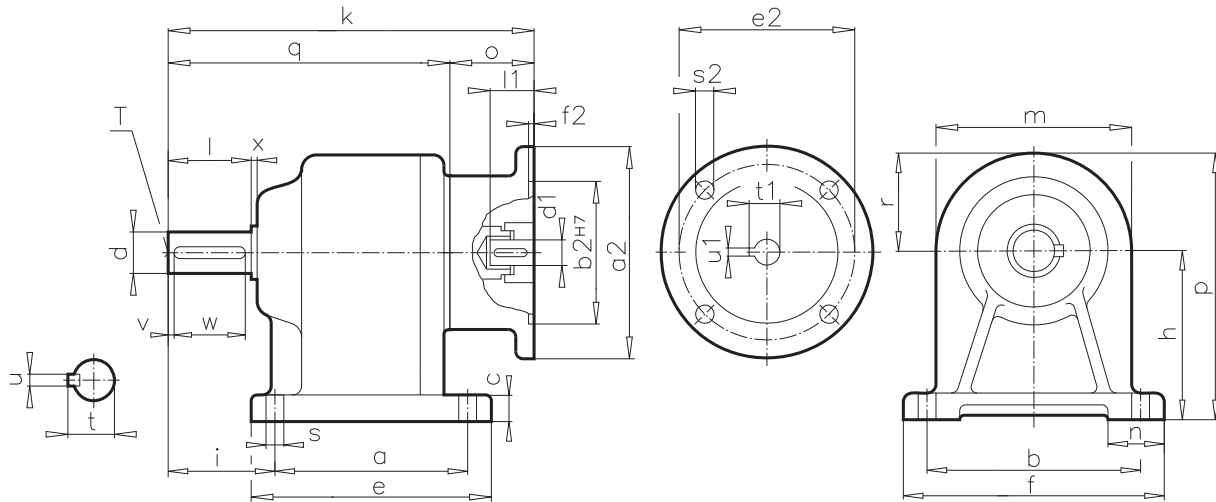

Typ Type Type	Befestigungsmaße (Fuß) Mounting dimensions (foot) Cotes de fixation (pattes)								Raum- und Anschlußmaße Outline dimensions Cotes d'encombrement								Wellenmaße Shaft dimensions Cotes arbre			
	a	b	c	e	f	n	s	h	i	k	m	o	p	q	r	d	t	v	x	
	l	u	w	T																
SK 0 - IEC 63 - IEC 71 - IEC 80	50	110	12	78	130	20	8,5	86	52	241	103	136	138	50,0	16	18,0	4	2		
								248	110	110	40				5	32	M 5			
								290	152											
SK 01 - IEC 63 - IEC 71 - IEC 80 - IEC 90	85	105	15	110	135	30	8,5	102	68	252	103	170	149	67,5	20	22,5	5	2		
								259	135	110	40				6	30	M 6			
								301	152											
								301	152											
SK 20 - IEC 63 - IEC 71 - IEC 80 - IEC 90	80	160	18	110	185	30	11	125	74	290	103	200	187	75,0	25	28,0	10	2		
								297	150	110	60				8	40	M 10			
								339	152											
								339	152											
SK 25 - IEC 80 - IEC 90 - IEC 100 - IEC 112	140	155	20	175	190	35	13	130	115	384	163	215	221	85,0	30	33,0	10	2		
								384	170	163	70				8	50	M 10			
								381	160											
								381	160											
SK 30 - IEC 80 - IEC 90 - IEC 100 - IEC 112	90	185	20	125	210	35	13	155	86	382	163	240	219	85,0	35	38,0	10	3		
								382	170	163	70				10	50	M 12			
								379	160											
								379	160											
SK 33 - IEC 90 - IEC 100 - IEC 112 - IEC 132	134	175	25	165	215	40	13	175	120	413	163	275	250	100	40	43,0	10	3		
								410	200	160	80				12	60	M 16			
								410	160											
								425	175											
SK 01 V - IEC 63 - IEC 71 - IEC 80 - IEC 90	85	105	15	110	135	30	8,5	102	68	252	103	170	149	67,5	20	22,5	5	2		
								259	135	110	40				6	30	M 6			
								301	152											
								301	152											
SK 20 V - IEC 80 - IEC 90	80	160	18	110	185	30	11	125	74	358	150	163	200	195	75	25	28,0	10	2	
								358	163						60	8	40	M 10		
SK 30 V - IEC 90 - IEC 100 - IEC 112	90	185	20	125	210	35	13	155	86	382	157	240	225	85,0	35	38,0	10	3		
								379	170	154	70				10	50	M 12			
								379	154											
SK 33 V - IEC 100 - IEC 112 - IEC 132	134	175	25	165	215	40	13	175	120	416	160	275	256	100	40	43,0	10	3		
								416	200	160	80				12	60	M 16			
								431	175											

Motorbaugröße Motor frame size Taille moteur	Motoranbaumaße Motor mounting dimensions Cotes de montage du moteur									Paßfeder Key Clavette	Kupplungs - Typ Type of coupling Type d'accouplement
	a2	b2	e2	f2	s2	d1	l1	t1	u1		
63	140	95	115	3,5	M 8	11	23	12,8	4	A 4 x 4 x 18	R 14
71	160	110	130	4,0	M 8	14	30	16,3	5	A 5 x 5 x 25	R 14
80	200	130	165	4,0	M 10	19	40	21,8	6	A 6 x 6 x 35	R 24 / 28
90	200	130	165	4,0	M 10	24	50	27,3	8	A 8 x 7 x 40	R 24 / 28
100	250	180	215	5,0	M 12	28	60	31,3	8	A 8 x 7 x 50	R 38
112	250	180	215	5,0	M 12	28	60	31,3	8	A 8 x 7 x 50	R 38
132	300	230	265	5,0	M 12	38	80	41,3	10	A 10 x 8 x 60	R 42

Technische Änderungen vorbehalten

Technical design may be subject to change.

Sous réserve de modifications techniques.

STIRNRADGETRIEBE HELICAL GEAR UNITS REDUCTEURS A ENGRENAGES CYLINDRIQUES



ZUM ANFLANSCHEN VON IEC-NORMMOTOREN NACH DIN 42677 - TYP IEC , ZWEISTUFIG
FOR ASSEMBLY WITH IEC STANDARD MOTORS ACC: TO DIN 42677 - TYPE IEC , DOUBLE REDUCTION
POUR MONTAGE MOTEURS NORME SELON DIN 42677 - TYPE IEC , A DEUX TRAINS D'ENGRENAGES

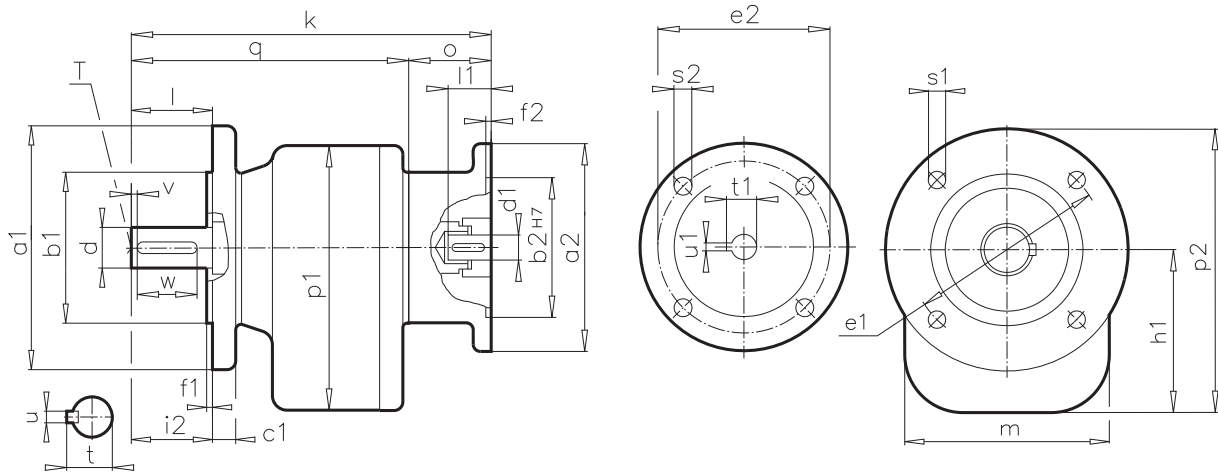

Typ Type Type	Befestigungsmaße (Flansch) * Mounting dimensions (flange) * Cotes de fixation (bride) *						Raum- und Anschlußmaße Outline dimensions Cotes d'encombrement							Wellenmaße Shaft dimensions Cotes arbre				
	a1	b1	c1	e1	f1	s1	h1	i2	k	m	o	p1	p2	q	d	t	v	T
							l	u	w									
SK 0 F - IEC 63 - IEC 71 - IEC 80	120	80	10	100	3,0	7	85	40	241 248 290	110	103 110 152	135	145	138	16	18,0	4	M 5
SK 01 F - IEC 63 - IEC 71 - IEC 80 - IEC 90	140 160	95 110	10 10	115 130	3,0 3,5	9 9	98	40	252 259 301 301	135	103 110 152 152	166	178	149	20 40	22,5 6	5 30	M6
SK 20 F - IEC 63 - IEC 71 - IEC 80 - IEC 90	160	110	10	130	3,5	9	123	60	290 297 339 339	150	103 110 152 152	198	203	187	25 60	28,0 8	10 40	M10
SK 25 F - IEC 80 - IEC 90 - IEC 100 - IEC 112	160	110	12	130	3,5	9	128	70	384 384 381 381	170	163 163 160 160	213	208	221	30 70	33,0 8	10 50	M10
SK 30 F - IEC 80 - IEC 90 - IEC 100 - IEC 112	200	130	12	165	3,5	11	153	70	382 382 379 379	170	163 163 160 160	238	253	219	35 70	38,0 10	10 50	M12
SK 33 F - IEC 90 - IEC 100 - IEC 112 - IEC 132	250	180	16	215	4,0	14	173	80	413 410 410 425	200	163 160 160 175	273	298	250	40 80	43,0 12	10 60	M16
SK 01 V F - IEC 63 - IEC 71 - IEC 80 - IEC 90	140 160	95 110	10 10	115 130	3,0 3,5	9 9	98	40	252 259 301 301	135	103 110 152 152	166	178	149	20 40	22,5 6	5 30	M6
SK 20 V F - IEC 80 - IEC 90 - IEC 90	160	110	10	130	3,5	9	123	60	358 358	150	163 163	198	203	195	25 60	28,0 8	10 40	M10
SK 30 V F - IEC 100 - IEC 112	200	130	12	165	3,5	11	153	70	382 379 379	170	157 154 154	238	253	225	35 70	38,0 10	10 50	M12
SK 33 V F - IEC 100 - IEC 112 - IEC 132	250	180	16	215	4,0	14	173	80	416 416 431	200	160 160 175	273	298	256	40 80	43,0 12	10 60	M16

Motoranbaumaße siehe Seite 58

Motor mounting dimensions see page 58

Cotes de montage du moteur voir page 58

* Fettgedruckte Flanschmaße beziehen sich auf die Normalausführung.
Weitere Flansche siehe Seite 63.

* Bold typed dimensions refer to standard design.
Further flanges see page 63.

* Cotes imprimées en caractères gras se réfèrent à l'exécution normale.
D'autres brides voir page 63.

STIRNRADGETRIEBE HELICAL GEAR UNITS REDUCTEURS A ENGRENAGES CYLINDRIQUES



ZUM ANFLANSCHEN VON IEC-NORMMOTOREN NACH DIN 42677 - TYP IEC , DREISTUFIG
FOR ASSEMBLY WITH IEC STANDARD MOTORS ACC: TO DIN 42677 - TYPE IEC , TRIPLE REDUCTION
POUR MONTAGE MOTEURS NORME SELON DIN 42677 - TYPE IEC , A TROIS TRAINS D'ENGRENAGES

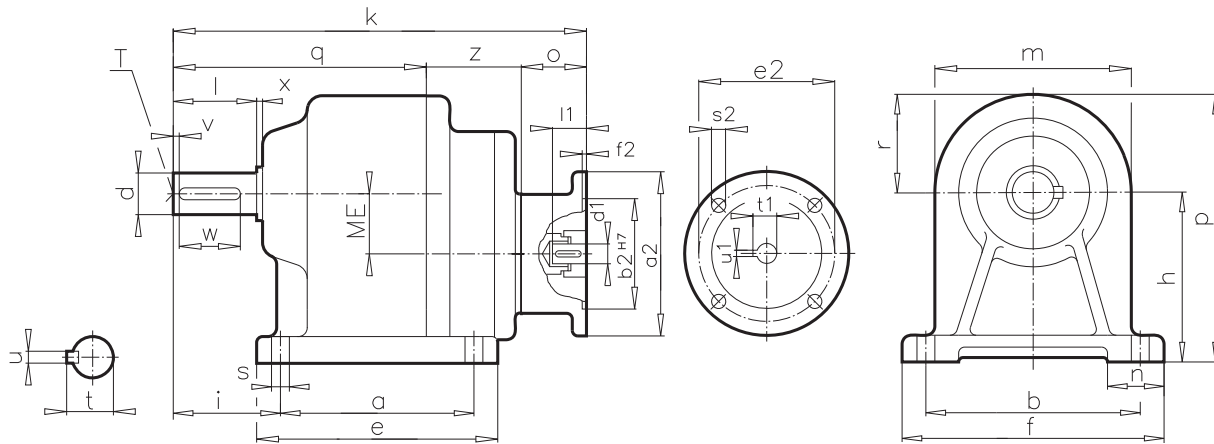

Typ Type Type	Befestigungsmaße (Fuß) Mounting dimensions (foot) Cotes de fixation (pattes)							Raum- und Anschlußmaße Outline dimensions Cotes d'encombrement											Wellenmaße Shaft dimensions Cotes arbre									
	a	b	c	e	f	n	s	h	i	k	m	o	p	q	r	z	ME	d	t	v	x							
																		l	u	w	T							
SK 010	- IEC 63									292		103							20	22,5	5	2						
	- IEC 71							85	105	15	110	135	30	8,5	102	68		135		170	132	67,5	57	32	40	6	30	M6
SK 200	- IEC 63									340		103						25	28,0	10	2							
	- IEC 71							80	160	18	110	185	30	11	125	74		150		200	172	75,0	65	32	60	8	40	M10
SK 250	- IEC 63									368		103						30	33,0	10	2							
	- IEC 71							140	155	20	175	190	35	13	130	115		170		215	200	85,0	65	47	70	8	50	M10
	- IEC 80									417		152						70	8	50	M10							
	- IEC 90									417		152																
SK 300	- IEC 63									366		103						35	38,0	10	3							
	- IEC 71							90	185	20	125	210	35	13	155	86		170		240	198	85,0	65	47	70	10	50	M12
	- IEC 80									415		152						70	10	50	M12							
	- IEC 90									415		152																
SK 330	- IEC 80									467		163						40	43,0	10	3							
	- IEC 90							134	175	25	165	215	40	13	175	120		200		275	223	100	81	65	80	12	60	M16

Motorbaugröße Motor frame size Taille moteur	Motoranbaumaße Motor mounting dimensions Cotes de montage du moteur									Paßfeder Key Clavette	Kupplungs - Typ Type of coupling Type d'accouplement
	a2	b2	e2	f2	s2	d1	l1	t1	u1		
63	140	95	115	3,5	M 8	11	23	12,8	4	A 4 x 4 x 18	R 14
71	160	110	130	4,0	M 8	14	30	16,3	5	A 5 x 5 x 25	R 14
80	200	130	165	4,0	M10	19	40	21,8	6	A 6 x 6 x 35	R 24 / 28
90	200	130	165	4,0	M10	24	50	27,3	8	A 8 x 7 x 40	R 24 / 28

STIRNRADGETRIEBE HELICAL GEAR UNITS REDUCTEURS A ENGRENAGES CYLINDRIQUES



ZUM ANFLANSCHEN VON IEC-NORMMOTOREN NACH DIN 42677 - TYP IEC , DREISTUFIG
FOR ASSEMBLY WITH IEC STANDARD MOTORS ACC: TO DIN 42677 - TYPE IEC , TRIPLE REDUCTION
POUR MONTAGE MOTEURS NORME SELON DIN 42677 - TYPE IEC , A TROIS TRAINS D'ENGRENAGES

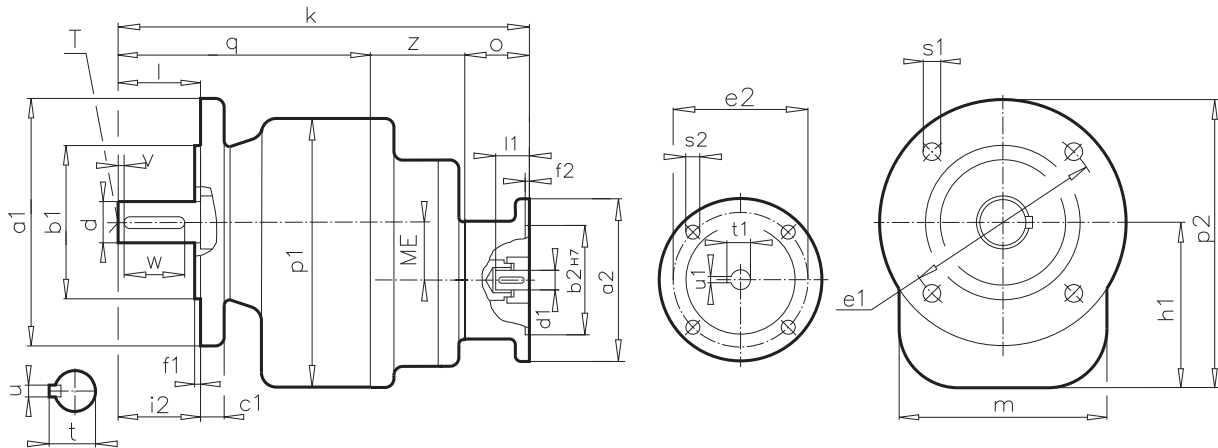

Typ Type Type	Befestigungsmaße (Fuß) * Mounting dimensions (foot) * Cotes de fixation (pattes) *						Raum- und Anschlußmaße Outline dimensions Cotes d'encombrement									Wellenmaße Shaft dimensions Cotes arbre				
	a1	b1	c1	e1	f1	s1	h1	i2	k	m	o	p1	p2	q	z	ME	d	t	v	T
																	l	u	w	
SK 010 F	- IEC 63	140	95	10	115	3,0	9			292		103	168				20	22,5	5	M6
	- IEC 71	160	110	10	130	3,5	9	98	40	299	135	110	178	132	57	32	40	6	30	
SK 200 F	- IEC 63									340		103					25	28,0	10	M10
	- IEC 71	160	110	10	130	3,5	9	123	60	347	150	110	198	203	172	65	60	8	40	
SK 250 F	- IEC 63									368		103					30	33,0	10	M10
	- IEC 71									375		110					70	8	50	
	- IEC 80	160	110	12	130	3,5	9	128	70	417	170	152	213	213	200	65	70	8	50	
	- IEC 90									417		152								
SK 300 F	- IEC 63									366		103					35	38,0	10	M12
	- IEC 71									373		110					70	10	50	
	- IEC 80	200	130	12	165	3,5	11	153	70	415	170	152	238	253	198	65	70	10	50	
	- IEC 90									415		152								

Motoranbaumaße siehe Seite 60

Motor mounting dimensions see page 60

Cotes de montage du moteur voir page 60

* Fettgedruckte Flanschmaße beziehen sich auf die Normalausführung.
Weitere Flansche siehe Seite 63.

* Bold typed dimensions refer to standard design.
Further flanges see page 63.

* Cotes imprimées en caractères gras se réfèrent à l'exécution normale.
D'autres brides voir page 63.

STIRNRADGETRIEBE HELICAL GEAR UNITS REDUCTEURS A ENGRENAGES CYLINDRIQUES



MIT FLANSCH B14 / MIT ANTRIEBSSEITIGEM FLANSCH
WITH FLANGE B14 / WITH FLANGE ON INPUT SIDE
AVEC BRIDE B14 / AVEC BRIDE COTE ENTRAINEMENT

STIRNRADGETRIEBE MIT FLANSCH B14 HELICAL GEAR UNITS WITH FLANGE B14 REDUCTEURS A ENGRENAGES CYLINDRIQUES AVEC BRIDE B14

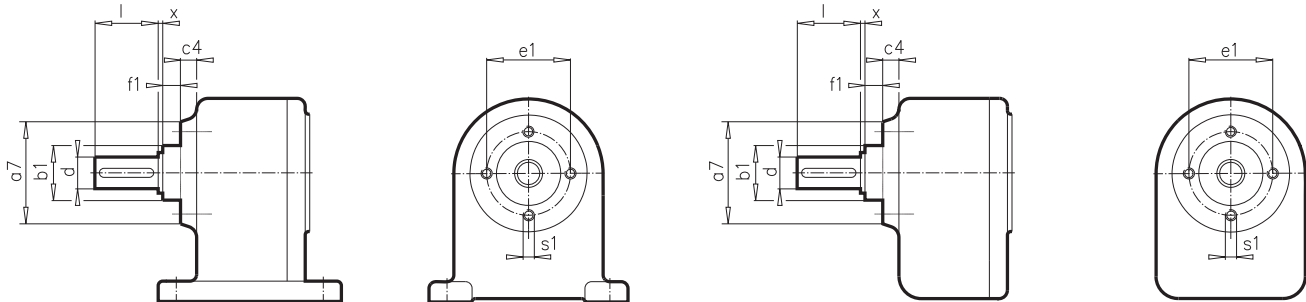

Typ Type Type	Fußausführung mit Flansch B14 Foot mounting with flange B14 Exécution à pattes avec bride B14									Flanschausführung mit Flansch B14 Flange mounting with flange B14 Exécution à bride avec bride B14								
	a1	b1	c4	e1	f1	s1	d	l	x	a1	b1	c4	e1	f1	s1	d	l	x
	SK 0	67	45	16	58	10	M5x11	16	40	2	75	45	16	58	10	M5x15	16	40
SK 05	auf Anfrage / on request / sur demande									— — — — — — — — —								
SK 01, SK 010	85	57	34	70	10	M6x15	20	40	2	85	57	35	70	10	M6x15	20	40	2
SK 015, SK 0105	82	57	32	70	10	M6x15	25	60	2	95	62	22	79	12	M8x15	25	60	2
SK 20, SK 200	95	62	13	79	12	M8x15	25	60	2	95	62	13	79	12	M8x15	25	60	2
SK 205, SK 2005	94	66	13	79	4	M8x15	30	70	11	115	72	31	90	16	M8x15	30	70	2
SK 25, SK 250	105	72	49	90	16	M8x20	30	70	2	105	72	43	90	16	M8x20	30	70	2
SK 255, SK 2505	105	78	50	90	4	M8x20	35	70	14	115	82	45	100	15	M8x15	35	70	3
SK 30, SK 300	115	82	20	100	15	M8x15	35	70	3	115	82	40	100	15	M8x15	35	70	3
SK 305, SK 3005	auf Anfrage / on request / sur demande									132 94 37 115 18 M10x25 40 80 3								
SK 33, SK 330	138	94	53	115	18	M10x25	40	80	3	132	94	44	115	18	M10x25	40	80	3
SK 335, SK 3305	136	99	53	120	18	M10x20	50	100	3	168	110	40	140	22	M12x30	50	100	3

STIRNRADGETRIEBE MIT ANTRIEBSSEITIGEM FLANSCH HELICAL GEAR UNITS WITH FLANGE ON INPUT SIDE REDUCTEURS A ENGRENAGES CYLINDRIQUES AVEC BRIDE COTE ENTRAINEMENT

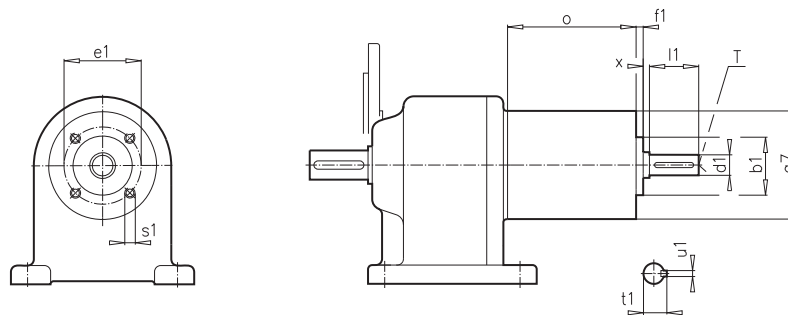

Typ Type Type	Raum- und Anschlußmaße Outline dimensions Cotes d'encombrement						Wellenmaße Shaft dimensions Cotes d'arbre					
	a7	b1	e1	f1	s1	o	d1	l1	t1	u1	x	T
SK 0 - W0	90	—	75	—	M 5 x 10	78	14	40	16	5	0,5	M 5 x 10
SK 01 - W0	—	—	—	—	—	—	—	—	—	—	—	—
SK 01 - WII SK 300 - WII SK 20 - WII	120	60	100	6	M 6 x 12	59	16	40	48	5	2,0	M 6 x 12
SK 20 V - WIII	140	70	125	6	M 8 x 16	63	24	50	27	8	2,0	M 8 x 16
SK 25 - WI	140	70	125	6	M 8 x 16	63	24	50	27	8	2,0	M 8 x 16
SK 30 - WI	140	70	125	6	M 8 x 16	63	24	50	27	8	2,0	M 8 x 16
SK 330 - WI	140	70	125	6	M 8 x 16	63	24	50	27	8	2,0	M 8 x 16
SK 33 - WI	170	80	150	6	M 8 x 16	112	28	60	31	8	3,0	M 8 x 16

**STIRNRADGETRIEBE
HELICAL GEAR UNITS
REDUCTEURS A ENGRENAGES CYLINDRIQUES**



LIEFERBARE FLANSCHEN
AVAILABLE FLANGES
BRIDES LIVRABLES

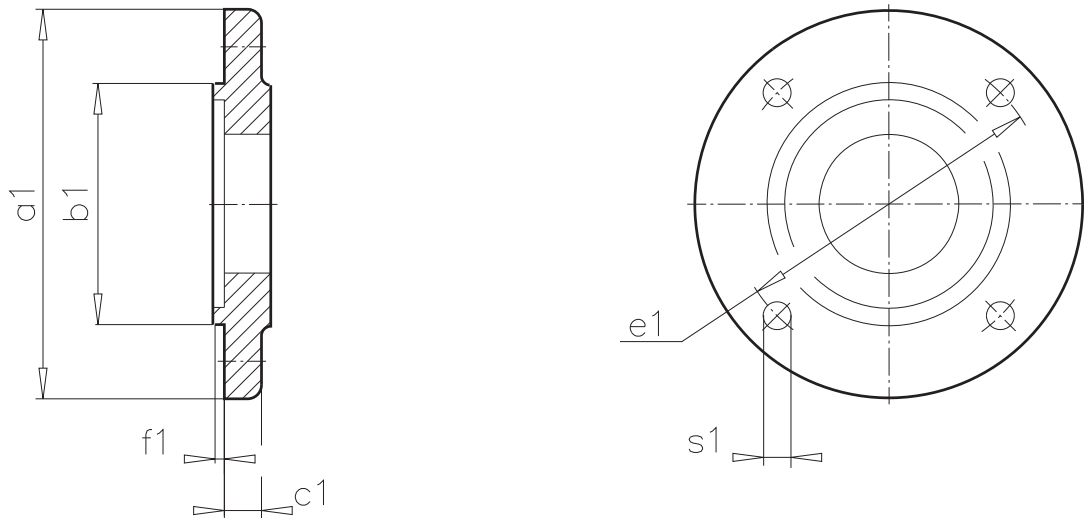

Typ Type Type	Lieferbare Flansche für Stirnradgetriebe Available flanges for Helical Gear Units Brides livrables pour réducteurs à engrenages cylindriques						
	a1	b1	c1	e1	f1	s1	
SK 0	105	70	10	85	3,0	M 6	
	120	80	10	100	3,0	7	
	140	95	10	115	3,0	9	
	160	110	10	130	3,5	9	
SK 01	120	80	10	100	3,0	7	
SK 010	140	95	10	115	3,0	9	
	160	110	10	130	3,5	9	
	200	130	10	165	3,5	11	
	250	180	10	215	4,0	14	
SK 015 , SK 20	140	95	10	115	3,0	9	
SK 0105 , SK 200	160	110	10	130	3,5	9	
	200	130	12	165	3,5	11	
	250	180	12	215	4,0	14	
	300	230	12	265	4,0	14	
SK 205 , SK 25	160	110	12	130	3,5	9	
SK 2005 , SK 250	200	130	12	165	3,5	11	
	250	180	12	215	4,0	14	
	300	230	12	265	4,0	14	
SK 255 , SK 30	160	110	12	130	3,5	9	
SK 2505 , SK 300	200	130	12	165	3,5	11	
	250	180	12	215	4,0	14	
	300	230	12	265	4,0	14	
SK 305 , SK 33	200	130	14	165	3,5	11	
SK 3005 , SK 330	250	180	16	215	4,0	14	
	300	230	16	265	4,0	14	
SK 335	250	180	16	215	4,0	14	
SK 3305	300	230	20	265	4,0	14	
	350	250	20	300	5,0	18	

Fettgedruckte Flanschmaße beziehen sich auf die Normalausführung.

Die anderen Flansche können alternativ gegen Mehrpreis geliefert werden.

Technische Änderungen vorbehalten

Bold typed dimensions refer to standard design.

All other flanges can be supplied optionally with surcharges.

Technical design may be subject to change.

Cotes imprimées en caractères gras se réfèrent à l'exécution normale.

Les autres brides peuvent être livrées sur commandes avec supplément.

Sous réserve de modifications techniques.

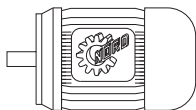

MOTOR MOTOR MOTEUR



TECHNISCHE ERLÄUTERUNGEN EXPLANATORY NOTES DESCRIPTIONS TECHNIQUES

MOTOREN

Die angebaute Drehstrommotoren entsprechen den einschlägigen Normen und Vorschriften, z.B. EN 60034, Teil 1, 5, 6, 7, 8, 9.

SPANNUNG UND FREQUENZ

Die folgenden Spannungen sind lieferbar:

220V/380V 230V/400 V 50 Hz	380V Δ 400V Δ 50 Hz	290V/500V 50 Hz	500V Δ 50 Hz	440V/ Y 60 Hz 460V/ Y 60 Hz	440V Δ 60 Hz 460V Δ 60 Hz
----------------------------------	---------------------------	--------------------	-----------------	--------------------------------------	------------------------------------

Für 50 Hz gewickelte Motoren können auch an 60 Hz Netze angeschlossen werden. Die dadurch eintretenden Drehzahl-, Leistungs- und Momentänderungen sind in der Tabelle ersichtlich.

Spannungsumschaltbare Motoren, die an 220 V und auch an 440 V-Netzen betrieben werden sollen, bitten wir anzufordern.

Umrechnungsfaktoren für die in der Liste angegebenen Leistungsdaten

Motorwicklung 50 Hz Motorwinding 50 Hz Moteur bobinage 50 Hz	Anschluß an 60 Hz Connection to 60 Hz Raccordement en 60 Hz	Nennzahl Rated speed Vitesse nominale	Nennleistung Rated output Puissance nominale	Nennmoment Rated torque Couple nominale	Nennstrom Rated current Intensité nominale	M _A / M _N M _A / M _N M _A / M _N
230V	230V	1,20	1,00	0,83	1,00	0,83
400V	400V	1,20	1,00	0,83	1,00	0,83
440V	440V	1,20	1,00	0,83	1,00	0,83
500V	500V	1,20	1,00	0,83	1,00	0,83
380V	440V	1,20	1,15	1,00	1,00	1,00
500V	550V	1,20	1,10	0,91	1,00	0,91
400V	460V	1,20	1,15	1,00	1,00	1,00

Spannungstoleranz nach IEC 38 / Voltage tolerance according to IEC 38 / Tolérances de tension suivant IEC 38

MOTORS

All motors are in accordance with current standards and regulations, such as EN 60034, part 1, 5, 6, 7, 8, 9.

VOLTAGE AND FREQUENCY

The following voltages are available:

Motors wound for 50 Hz can also be connected to 60 Hz supply. Please note the resulting changes in speed, power and torque as per following table.

Please enquire multi-voltage motors for supply of 220/440 V, if required.

Conversion-factors for performance figures in list

MOTEURS

Les moteurs montés correspondent aux normes et réglementations telles que: EN 60034, partie 1, 5, 6, 7, 8, 9.

TENSION ET FREQUENCE

Les tension ci-après sont livrables:

Les moteurs avec un bobinage conçu pour 50 Hz peuvent également être alimentés par une fréquence de 60 Hz. Les nouvelles valeurs de vitesse, puissance et couple sont indiquées dans le tableau ci-dessous.

Veillez nous consulter à nous en ce qui concerne les moteurs à tension commutable pouvant être raccordés aussi bien en 220 V qu'en 440 V.

Facteur de conversion pour les données de puissance catalogue

BEMESSUNGSSPANNUNGSBEREICH

Motoren, die für eine Netzspannung nach EN 60038 mit der Gesamtteranz von ± 10% einsetzbar sein sollen, können für einen der nachstehend genannten Bemessungsspannungsbereiche ausgeführt werden:

Netzspannung nach EN 60038

230 V ± 10%
400 V ± 10%
690 V ± 10%

POLUMSCHALTBARE MOTOREN

Die polumschaltbaren Motoren werden mit einer Wicklung in Dahlanderschaltung (Drehzahlverhältnis 2:1) oder mit getrennten Wicklungen (Drehzahlverhältnisse 3:1, 4:1, 6:1, 3:2) ausgeführt. Durch Kombination von beiden Wicklungsarten sind auch 3-fach polumschaltbare Motoren möglich.

ERWÄRMUNG

Die Nennleistung gilt für Dauerbetrieb, entsprechend EN 60034 für eine max. Umgebungstemperatur von 40°C sowie eine Aufstellungshöhe bis 1.000 m ü.NN. Bei abweichenden Bedingungen ist die zulässige Leistung der nachstehenden Tabelle zu entnehmen.

RATED VOLTAGE-RANGE

Motors to be operated on a supply according to EN 60038 with a tolerance of ± 10% can be supplied for one of the following Voltage-Ranges:

Supply Voltage acc. to EN 60038

230 V ± 10%
400 V ± 10%
690 V ± 10%

POLECHANGING MOTORS

Our polechanging motors are designed with one winding for Dahlander connection (speed ratio 2:1) or with separate windings (speed ratios 3:1, 4:1, 6:1, 3:2). A combination of both winding types enables the production of triple-speed motors.

TEMPERATURE RISE

As specified in EN 60034, the motor ratings are based on continuous duty, maximum ambient temperature of 40°C at altitudes up to 1000 metres above sea level. The permissible output in the case of other conditions is tabulated below.

PLAGE DE TENSION

Les moteurs qui sont prévus pour des tensions réseau suivant l'EN 60038 avec tolérance ± 10%, pourront être utilisés pour des plages de tension mesurées comme ci-après:

Tension réseau suivant EN 60038

230 V ± 10%
400 V ± 10%
690 V ± 10%

MOTEURS A COMMUTATION DE POLES

Les moteurs à commutation de pôles sont conçus avec un enroulement à couplage Dahlander (rapport de vitesse 2:1) ou avec des enroulements séparés (rapports de vitesse 3:1, 4:1, 6:1; 3:2). Il est possible d'obtenir des moteurs à commutation de pôles triple en combinant ces deux types d'enroulement.

ECHAUFFEMENT

La puissance nominale indiquée est valable en service continu, selon EN 60034, pour une température ambiante maximale de 40°C et une altitude jusqu'à 1000m. Pour d'autres conditions il y a lieu de se reporter au tableau ci-après.

Kühltemperatur [°C] Ambient temperature [°C] Température de refroidissement [°C]	zulässige Leistung in % der Nennleistung permissible output in % of rated power Puissance admissible en % de la puissance nom.	Aufstellungshöhe in m ü. NN Site altitude above sea level in metres Altitude en m	zulässige Leistung in % der Nennleistung permissible output in % of rated power Puissance admissible en % de la puissance nom.
40	100	1000	100
45	96	1500	97
50	92	2000	94
55	87	2500	90
60	82	3000	86
		3500	83
		4000	80

Ständerwicklungen der Motoren sind in Isolierstoffklasse F nach EN 60034 ausgeführt.

The windings are insulation class F according to EN 60034.

Les bobinage des stators des moteurs sont conçus selon la classe d'isolation F conformément à la norme EN 60034.

Isolierstoffklasse	Grenzüber- temperatur [K]	Höchstzulässige Dauertemperatur [°C]
F	105	155

Insulation class	Max. permissible temperature rise [K]	Max. permissible continuous temperature [°C]
F	105	155

Classe d'isolation	Echauffement limite [K]	Température max. admissible en service cont. [°C]
F	105	155



MOTOR MOTOR MOTEUR

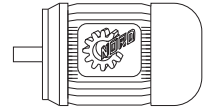

TECHNISCHE ERLÄUTERUNGEN EXPLANATORY NOTES DESCRIPTIONS TECHNIQUES

MOTORSCHUTZ

Bei stromabhängigem Motorschutz muß der Schutzschalter auf den am Leistungsschild angegebenen Nennstrom eingestellt werden. Bei Schalthäufigkeit, Kurzzeitbetrieb oder großen Kühlmitteltemperaturschwankungen ist der Motorschutz nur mit direkter Temperaturüberwachung sinnvoll.

Hierzu bieten sich gegen Mehrpreis folgende Möglichkeiten an:

a) Temperaturwächter als Öffner

Bei Erreichung der Grenztemperatur öffnet dieser selbsttätig den Hilfsstromkreis und schaltet erst nach wesentlicher Temperaturänderung wieder ein. Schaltleistung: Bei Wechselspannung 250 V 1,6 A.

b) Kaltleiterschutz

Die eingebauten Kaltleiterfühler können nur in Verbindung mit einem Auslösegerät betrieben werden (gehört nicht zum NORD - Lieferumfang). Bei Erreichen der Grenztemperatur ändert der Kaltleiterfühler sprunghaft seinen Widerstand. In Verbindung mit dem Auslösegerät wird diese Wirkung zur Überwachung der Motortemperatur ausgenutzt. Das im Gerät eingebaute Relais verfügt über einen Umschaltkontakt dessen Öffner und Schließer für die Steuerung benutzt werden können. Vorteil: Schutzeinrichtung überwacht sich selbst; geringe Schalttoleranz ca. ± 5 K; schnelles Wiedereinschalten des Antriebes.

Zu beachten: Keine Spannung an die Kaltleiterfühler anlegen.

Isolations- klasse	F	
	Warnen	Absch.
NAT/°C	130	155

SCHUTZARTEN

Die Motoren sind serienmäßig in Schutzart IP 55 ausgeführt.

Die Bremsmotoren sind serienmäßig in Schutzart IP 54 ausgeführt.

Auf Wunsch sind Schutzarten wie IP 56, IP 65 und IP 66 gegen Mehrpreis lieferbar

Grundsätzlich bestimmen die Einsatz- und Umweltbedingungen die erforderliche Schutzart sowie eventuelle zusätzliche Maßnahmen. Für Aussenaufstellung in vertikaler Bauformen sind bezüglich Abdichtung, Lüfterhaube und Lagerschmierung besondere Maßnahmen notwendig. Bei Bestellung bitte unbedingt den Hinweis auf "Aussenaufstellung - vertikal" angeben.

NEMA UND CSA

Die listenmäßigen Motoren erfüllen die amerikanischen "NEMA"-Vorschriften nur elektrisch, nicht mechanisch. Motoren mit Abmessungen nach NEMA sind gegen Mehrpreis lieferbar.

CSA - Motoren sind lieferbar in den Ausführungen 230 / 460 V - 60 Hz bzw. 332 / 575 V - 60 Hz.

VIK-Motoren, die den technischen Anforderungen der VIK (Vereinigte Industrielle Kraftwirtschaft) entsprechen, sind gegen Mehrpreis lieferbar.

BETRIEBSARTEN

Die im Katalog aufgeführten Motoren sind für Betriebsart S1 (Dauerbetrieb), nach EN 60034/1, ausgelegt. Zur Auslegung der Motoren bei anderen Betriebsarten benötigen wir folgende Angaben:

- relative Einschaltdauer
- Lastmomentkennlinie über Drehzahlbereich
- auf die Motorwelle reduziertes Fremdmassenträgheitsmoment
- Art der Bremsung

EINSCHALTUNG

Die Motoren sind für die direkte Einschaltung geeignet, dabei können jedoch nach Größe das 3-fache des Nennmomentes und das 8-fache des Nennstromes erreicht werden. Bei Stern-Dreieck-Anlauf (z.B. Anschlußbestimmung des zuständigen Elektrizitätswerkes) können diese Maximalwerte auf ca. 1/3 reduziert werden. Voraussetzung ist jedoch, daß die Spannung der im Dreieck geschalteten Motorwicklung mit der Netzspannung übereinstimmt.

MOTOR PROTECTION

Current-controlled motor-protection must be set acc. to rated current shown on nameplate. Operation involving high switching frequency, short term duty or large temperature-differences should be monitored by direct temperature-control.

Following options are available at surcharge:

a) Thermal trip as opener

Upon reaching the limit temperature this device automatically cuts the control-circuit and only after a significant drop in temperature this switch engages again. Contact-rating: 250 V AC, 1,6 A.

b) PTC Thermistor sensors

The built-in thermistors PTC can only be utilized with an external tripping-device(not part of NORD supply). Upon reaching the limit temperature the thermistors change their resistance suddenly. In connection with a tripping device this property is employed to monitor the motor temperature. The relays built into the tripping-device has a make-and-break-contact which is utilized for control purposes. Advantage: The control-device is self-monitoring, narrow switching-tolerance approx. ± 5 K; rapid restart of drive.

Note: Do not apply voltage to thermistors

Insulation class	F	
	warn	cut out
NAT/°C	130	155

TYPE OF PROTECTION

The standard enclosure of the motors is IP 55.

The standard enclosure of the brakemotors is IP 54.

If required, enclosures IP 56, IP 65 and IP 66 are available with surcharge.

Generally, application and ambient conditions determine the required type of protection and possible extra measures. For outdoor operation with vertical mounting special measures are required regarding sealing, fan cover and bearing lubrication. When ordering please clearly indicate "outdoor operation - vertical mounting".

NEMA AND CSA

The standard motors meet the American "NEMA Specifications" only in terms of electrical standards, not in terms of mechanical standards. Motors with dimensions acc. to NEMA are available at extra price.

CSA motors are available in designs 230 / 460 V - 60 Hz or 332 / 575 V - 60 Hz.

VIK-motors are available (extra price) to meet the technical requirements of the VIK (United Industrial Power Industry) dated June 1975.

MODES OF OPERATION

All motors in the catalogue are rated for duty S1 (continuous operation), to EN 60034/1. For selection of motors for other duties we need following details:

- relative cyclic duration factor
- characteristic torque curve over speed range
- external moment of inertia reduced to motor shaft
- type of braking

CONNECTION

The motors are suitable for DOL-starting. However, 3 times the rated torque and 8 times the rated current may result from this starting method. By Star-Delta starting these maximum figures may be reduced to 1/3 (e.g. regulations of power authorities), under the condition that the voltage in the Delta-connection corresponds with the grid.

PROTECTION DES MOTEURS

Les moteurs doivent être protégés par un relais thermique ou un disjoncteur magnétothermique, réglé à un seuil d'intensité correspondant à l'intensité nominale du moteur indiqué sur sa plaque signalétique.

Pour des démarrages fréquents, des temps de cycles très courts ou des variations importantes de la température ambiante, une protection particulière du moteur est recommandée.

Nous vous proposons contre supplément de prix:

a) Un déclencheur thermique à ouverture

Lorsque la température limite du moteur est atteinte le déclencheur s'ouvre. Il ne se refermera qu'après le refroidissement du moteur. Pouvoir de coupure: 1,6 A pour tension monophasée 250 V.

b) Thermistances CTP

Ces sondes ne peuvent fonctionner qu'avec un relais associé (non fournis par NORD). La résistance des sondes varie brutalement lorsque la température limite du moteur est atteinte. En liaison avec le relais, elles serviront de protection totale du moteur.

Avantage: faible tolérance de commutation environ ± 5 K; redémarrage rapide de l'installation.

Attention: Ne pas appliquer de tension au niveau des sondes

Classe d'isolation	F	
	Information	Arrêt
NAT/°C	130	155

TYPES DE PROTECTION

Les moteurs sont conçus en série avec le degré de protection IP 55.

Les moteur-frein sont conçus en série avec le degré de protection IP 54.

Sur demande, des degrés de protection IP 56, IP65 et IP 66 sont livrables contre supplément de prix.

De façon générale, l'application et l'environnement dans lequel est installé le moteur détermineront le degré de protection nécessaire. Par exemple, pour une installation en extérieur en position verticale, des mesures particulières concernant les étanchéités et le graissage des roulements sont nécessaires. Sur la commande il faut absolument mettre l'annotation "utilisation en extérieur, montage vertical".

NEMA ET CSA

Les moteurs standard répondent aux spécifications américaines "NEMA" uniquement du point de vue électrique mais pas du point de vue mécanique. Les moteurs répondant à la norme "NEMA" sont livrables contre supplément de prix.

Les moteurs aux normes CSA sont livrables avec les tensions 230 / 460 V -60 Hz ou bien 332 / 575 V -50 Hz.

Les moteurs VIK répondant aux exigences techniques de la norme VIK sont livrables contre un supplément de prix.

TYPES DE FONCTIONNEMENT

Les moteurs mentionnés dans ce catalogue sont conçus pour le type de fonctionnement S1 (fonctionnement continu), EN 60034/1. Nous avons besoin des indications suivantes pour déterminer les moteurs pour d'autres types de fonctionnement:

- durée de fonctionnement
- caractéristique du couple en fonction de la vitesse
- moment d'inertie externe ramené sur l'arbre du moteur
- type de freinage

DEMARRAGE

Les moteurs sont conçus pour des démarrages directs, et peuvent atteindre jusqu'à 3 fois le couple nominal et 8 fois l'intensité nominale.

Avec le démarrage étoile-triangle, ces valeurs maximales peuvent être réduites d'env. 1/3 à la condition, toutefois, que la tension du bobinage moteur couplé en triangle coïncide avec celle du réseau.

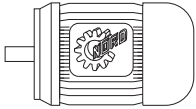

EINPHASENMOTOREN SINGLE PHASE MOTORS MOTEURS MONOPHASES



TECHNISCHE ERLÄUTERUNGEN EXPLANATORY NOTES DESCRIPTIONS TECHNIQUES

EINPHASENMOTOREN

Typ **EHB**: mit Betriebskondensator

Typ **EAR**: mit Betriebs- und Anlaufkondensator, der Anlaufkondensator wird nach dem Hochlauf durch ein Relais abgeschaltet

Typ **EST**: Drehstrommotor mit Betriebskondensator in Steinmetzschaltung

Die Einphasenmotore entsprechen den einschlägigen Normen und Vorschriften, z.B. EN 60034, Teil 1, 5, 6, 7, 8, 9.

SPANNUNG UND FREQUENZ

Die folgenden Spannungen sind lieferbar:
230 V - 50 Hz; 230 V - 60 Hz; 115/230 V - 60 Hz

SINGLE PHASE MOTORS

Type **EHB**: Capacitor run

Type **EAR**: Capacitor start
Capacitor run
Current operated relais

Type **EST**: 3 phase motor with capacitor in Steinmetz - Connection

All motors are in accordance with existing standards and regulations, such as EN 60034, part 1, 5, 6, 7, 8, 9.

VOLTAGE AND FREQUENCY

The following voltages are available:
230 V - 50 Hz; 230 V - 60 Hz; 115/230 V - 60 Hz

MOTEURS MONOPHASES

Type **EHB**: avec condensateur de fonctionnement

Type **EAR**: avec condensateur de fonctionnement et de démarrage, le condensateur de démarrage sera déconnecté par un relais une fois le démarrage terminé

Type **EST**: moteurs triphasés avec condensateur de fonctionnement et couplage Steinmetz

Les moteurs montés correspondent aux normes et réglementations telles que: EN 60034, partie 1, 5, 6, 7, 8, 9.

TENSION ET FREQUENCE

Les tensions ci-après sont livrables:
230 V - 50 Hz; 230 V - 60 Hz; 115/230 V - 60 Hz

MOTORDATEN / TECHNICAL DATA / CARACTERISTIQUES MOTEURS								EHB 230 V - 50 Hz	
Typ Frame size Taille	P_n [kW]	n_n [min ⁻¹]	η [%]	$\cos \varphi$	I_n (230 V) [A]	M_n [Nm]	M_a / M_n	Betr.-Kondensator Capacitor run Condens. de fonc.	[μ F]
63 S/4 EHB	0,12	1350	44	0,99	1,20	0,85	0,7	10,0	
63 L/4 EHB	0,18	1360	47	0,97	1,70	1,26	0,6	12,5	
71 S/4 EHB	0,25	1390	54	0,92	2,20	1,70	0,5	16,0	
71 L/4 EHB	0,37	1360	58	0,97	2,85	2,60	0,4	20,0	
80 S/4 EHB	0,55	1350	60	0,95	4,20	3,90	0,3	25,0	
80 L/4 EHB	0,75	1375	65	0,97	5,20	5,20	0,4	35,0	
90 S/4 EHB	1,10	1385	68	0,97	7,20	7,60	0,3	35,0	
90 L/4 EHB	1,50	1410	70	0,95	9,80	10,2	0,4	45,0	

MOTORDATEN / TECHNICAL DATA / CARACTERISTIQUES MOTEURS								EAR 230 V - 50 Hz				
Typ Frame size Taille	P_n [kW]	n_n [min ⁻¹]	η [%]	$\cos \varphi$	I_n (230 V) [A]	M_n [Nm]	M_a / M_n	Betr.-Kondensator Capacitor run Condens. de fonc.	[μ F]	Anlauf-Kondensator Capacitor start Condens. de démarrage	[μ F]	Anlauf - Relais Relay Relais
63 S/4 EAR	0,12	1350	44	0,99	1,20	0,85	2,6	10,0		25		2CR4 - 121
63 L/4 EAR	0,18	1360	47	0,97	1,70	1,26	2,3	12,5		30		2CR4 - 129
71 S/4 EAR	0,25	1390	54	0,92	2,20	1,70	2,3	16,0		40		2CR4 - 140
71 L/4 EAR	0,37	1360	58	0,97	2,85	2,60	2,3	20,0		60		2CR4 - 150
80 S/4 EAR	0,55	1350	60	0,95	4,20	3,90	2,5	25,0		80 - 100		2CR4 - 162
80 L/4 EAR	0,75	1375	65	0,97	5,20	5,20	2,3	35,0		80 - 100		2CR4 - 189
90 S/4 EAR	1,10	1385	68	0,97	7,20	7,60	2,5	35,0		160 - 200		2CR4 - 224
90 L/4 EAR	1,50	1410	70	0,95	9,80	10,2	2,5	45,0		200 - 250		2CR4 - 224

MOTORDATEN / TECHNICAL DATA / CARACTERISTIQUES MOTEURS								EST 230 V - 50 Hz	
Typ Frame size Taille	P_n [kW]	n_n [min ⁻¹]	η [%]	$\cos \varphi$	I_n (230 V) [A]	M_n [Nm]	M_a / M_n	Betr.-Kondensator Capacitor run Condens. de fonc.	[μ F]
63 S/4 EST	0,09	1390	41	0,98	0,97	0,62	0,81	16	
63 L/4 EST	0,12	1405	45	0,98	1,19	0,82	0,74	20	
71 S/4 EST	0,18	1415	53	0,97	1,52	1,20	0,66	25	
71 L/4 EST	0,25	1415	58	0,97	1,95	1,70	0,59	30	
80 S/4 EST	0,37	1425	64	0,96	2,62	2,50	0,44	40	
80 L/4 EST	0,55	1420	69	0,96	3,60	3,70	0,46	50	
90 S/4 EST	0,75	1435	74	0,96	4,60	5,00	0,40	60	
90 L/4 EST	1,10	1435	77	0,96	6,46	7,30	0,27	90	



EINPHASENMOTOREN SINGLE PHASE MOTORS MOTEURS MONOPHASES

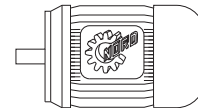

MOTORDATEN TECHNICAL DATA CARACTERISTIQUES MOTEURS

MOTORDATEN / TECHNICAL DATA / CARACTERISTIQUES MOTEURS EHB 230 V - 60 Hz								
Typ Frame size Taille	P_n [kW]	n_n [min ⁻¹]	η [%]	$\cos \varphi$	I_n (230 V) [A]	M_n [Nm]	M_a / M_n	Betriebs-Kondensator Capacitor run Condensateur de fonc. [μF]
63 S/4 EHB	0,12	1660	44	0,99	1,20	0,70	0,7	10
63 L/4 EHB	0,18	1670	47	0,97	1,70	1,03	0,6	12,5
71 S/4 EHB	0,25	1700	54	0,92	2,20	1,40	0,5	16
71 L/4 EHB	0,37	1670	58	0,97	2,85	2,10	0,4	20
80 S/4 EHB	0,55	1660	60	0,95	4,20	3,20	0,3	25
80 L/4 EHB	0,75	1680	65	0,97	5,20	4,30	0,4	35
90 S/4 EHB	1,10	1690	68	0,97	7,20	6,20	0,3	35
90 L/4 EHB	1,50	1710	70	0,95	9,80	8,40	0,4	45

MOTORDATEN / TECHNICAL DATA / CARACTERISTIQUES MOTEURS EHB 115 / 230 V - 60 Hz								
Typ Frame size Taille	P_n [kW]	n_n [min ⁻¹]	η [%]	$\cos \varphi$	I_n (115 / 230 V) [A]	M_n [Nm]	M_a / M_n	Betriebs-Kondensator Capacitor run Condensateur de fonc. [μF] *
63 S/4 EHB	0,12	1660	44	0,99	2,40 / 1,20	0,70	0,7	10
63 L/4 EHB	0,18	1670	47	0,97	3,4 / 1,70	1,03	0,6	12,5
71 S/4 EHB	0,25	1700	54	0,92	4,40 / 2,20	1,40	0,5	16
71 L/4 EHB	0,37	1670	58	0,97	5,70 / 2,85	2,10	0,4	20
80 S/4 EHB	0,55	1660	60	0,95	8,40 / 4,20	3,20	0,3	25
80 L/4 EHB	0,75	1680	65	0,97	10,4 / 5,20	4,30	0,4	35
90 S/4 EHB	1,10	1690	68	0,97	14,4 / 7,20	6,20	0,3	35
90 L/4 EHB	1,50	1710	70	0,95	19,6 / 9,80	8,40	0,4	45

MOTORDATEN / TECHNICAL DATA / CARACTERISTIQUES MOTEURS EAR 230 V - 60 Hz										
Typ Frame size Taille	P_n [kW]	n_n [min ⁻¹]	η [%]	$\cos \varphi$	I_n (230 V) [A]	M_n [Nm]	M_a / M_n	Betr.-Kondensator Capacitor run Condens. de fonc. [μF]	Anl.-Kondensator Capacitor start Condes. de démarrage [μF]	Anlauf - Relais Relay Relais
63 S/4 EAR	0,12	1660	44	0,99	1,20	0,70	2,6	10	25	2CR4 - 121
63 L/4 EAR	0,18	1670	47	0,97	1,70	1,03	2,3	12,5	30	2CR4 - 129
71 S/4 EAR	0,25	1700	54	0,92	2,20	1,40	2,3	16	40	2CR4 - 140
71 L/4 EAR	0,37	1670	58	0,97	2,85	2,10	2,3	20	60	2CR4 - 150
80 S/4 EAR	0,55	1660	60	0,95	4,20	3,20	2,5	25	80 - 100	2CR4 - 162
80 L/4 EAR	0,75	1680	65	0,97	5,20	4,30	2,3	35	80 - 100	2CR4 - 189
90 S/4 EAR	1,10	1690	68	0,97	7,20	6,20	2,5	35	160 - 200	2CR4 - 224
90 L/4 EAR	1,50	1710	70	0,95	9,80	8,40	2,5	45	160 - 200	2CR4 - 224

MOTORDATEN / TECHNICAL DATA / CARACTERISTIQUES MOTEURS EAR 115 / 230 V - 60 Hz										
Typ Frame size Taille	P_n [kW]	n_n [min ⁻¹]	η [%]	$\cos \varphi$	I_n (115 / 230 V) [A]	M_n [Nm]	M_a / M_n	Betr.-Kondensator Capacitor run Condens. de fonc. [μF] *	Anl.-Kondensator Capacitor start Condes. de démarrage [μF]	Anlauf - Relais Relay Relais
63 S/4 EAR	0,12	1660	44	0,99	2,40 / 1,20	0,70	2,6	10	25	2CR4 - 121
63 L/4 EAR	0,18	1670	47	0,97	3,40 / 1,70	1,03	2,3	12,5	30	2CR4 - 129
71 S/4 EAR	0,25	1700	54	0,92	4,40 / 2,20	1,40	2,3	16	40	2CR4 - 140
71 L/4 EAR	0,37	1670	58	0,97	5,70 / 2,85	2,10	2,3	20	60	2CR4 - 150
80 S/4 EAR	0,55	1660	60	0,95	8,40 / 4,20	3,20	2,5	25	80 - 100	2CR4 - 162
80 L/4 EAR	0,75	1680	65	0,97	10,4 / 5,20	4,30	2,3	35	80 - 100	2CR4 - 189
90 S/4 EAR	1,10	1690	68	0,97	14,4 / 7,20	6,20	2,5	35	160 - 200	2CR4 - 224
90 L/4 EAR	1,50	1710	70	0,95	19,6 / 9,80	8,40	2,5	45	160 - 200	2CR4 - 224

MOTORDATEN / TECHNICAL DATA / CARACTERISTIQUES MOTEURS EST 230 V - 60 Hz								
Typ Frame size Taille	P_n [kW]	n_n [min ⁻¹]	η [%]	$\cos \varphi$	I_n (230 V) [A]	M_n [Nm]	M_a / M_n	Betr.-Kondensator Capacitor run Condens. de fonc. [μF]
63 S/4 EST	0,09	1665	42	0,98	0,96	0,52	0,85	12
63 L/4 EST	0,12	1695	44	0,98	1,20	0,68	0,81	16
71 S/4 EST	0,18	1720	53	0,98	1,52	1,00	0,64	20
71 L/4 EST	0,25	1700	55	0,98	2,03	1,40	0,65	25
80 S/4 EST	0,37	1720	69	0,98	2,38	2,05	0,20	25
80 L/4 EST	0,55	1700	70	0,98	3,49	3,09	0,26	35
90 S/4 EST	0,75	1730	72	0,98	4,62	4,14	0,38	50
90 L/4 EST	1,10	1725	77	0,98	6,31	6,09	0,13	60

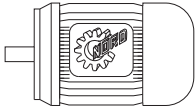

**MOTOR
MOTOR
MOTEUR**



**MOTORABMESSUNGEN - DREHSTROMMOTOREN
MOTOR DIMENSIONS - THREE PHASE MOTORS
DIMENSIONS DES MOTEURS - TRIPHASES**

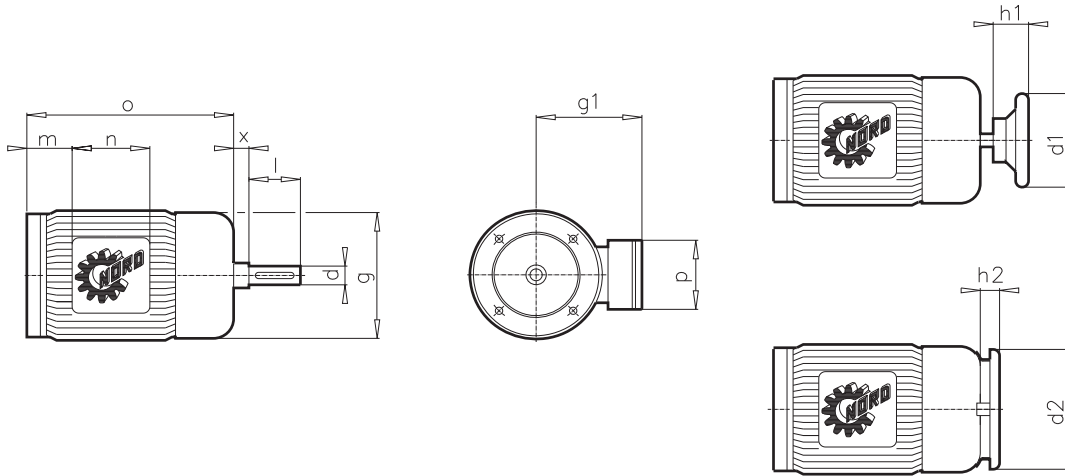

Motorbaugröße Motor frame size Taille moteur	Maße Dimensions Cotes moteur														OPTION / OPTION Einteiliger Klemmkasten One-piece terminal box Boîte à bornes d'une seule pièce			
	g	g1	m	n	o	p	d	l	x	d1	h1	d2	h2	g1	m	n	p	
	63 S + L	130	110	12	100	188	100	11	23	4	100	33	125	31	100	25	75	75
63 S + L (Bre)	130	118	14	132	244	87	11	23	3.5	100	33	121	12	—	—	—	—	
63 S + L (Ex)	130	138	27,5	105	190	110	11	23	5	100	33	125	31	—	—	—	—	
71 S + L	145	119	20	100	213	100	11	23	2	100	33	125	29	109	32	75	75	
71 S + L (Bre)	145	127	22	132	272	87	11	23	3.5	100	33	136	13	—	—	—	—	
71 S + L (Ex)	145	146	37,5	105	210	110	11	23	8	100	33	125	29	—	—	—	—	
80 S + L	165	140	22	114	231	114	14	30	8	100	33	125	26	124	33	92	92	
80 S + L (Bre)	165	141	24	153	300	108	14	30	5	100	33	154	16	—	—	—	—	
80 S + L (Ex)	162	154	47	105	234	110	14	30	10	100	33	125	26	—	—	—	—	
90 S + L	185	145	26	114	273	114	19	40	9	160	40	160	34	129	37	92	92	
90 S + L (Bre 10 + 20)	185	146	28	153	348	108	14	30	8	160	40	174	16	—	—	—	—	
90 S + L (Bre 40)	185	146	28	153	348	108	19	40	8	160	40	174	16	—	—	—	—	
90 S + L (Ex)	181	146	66	105	282	110	19	40	17	160	40	160	34	—	—	—	—	
100 L + L/40	203	154	32	114	306	114	24	50	6	160	40	160	34	140	43	92	92	
100 L + L/40 (Bre)	203	157	34	153	397	108	24	50	10	160	40	192	18	—	—	—	—	
100 L + L/40 (Ex)	203	158	81	105	312	110	24	50	16	160	40	160	34	—	—	—	—	
112 M + M/40	228	166	41	114	324	114	24	50	4	160	40	180	41	150	46	92	92	
112 M (Bre)	228	167	43	153	418	108	24	50	10	160	40	216	18	—	—	—	—	
112 M (Ex)	228	171	88	105	335	110	24	50	16	160	40	180	41	—	—	—	—	
132 S + M	266	194	55	122	411	122	32	80	18	200	45	220	46	174	55	105	105	
132 S + M (Bre)	266	193	47	185	518	139	32	80	10	200	45	255	21	—	—	—	—	
132 S/4 (Ex)	266	196	101	117	375	122	32	80	10	200	45	220	46	—	—	—	—	
132 M/4 (Ex)	266	196	101	117	423	122	32	80	10	200	45	220	46	—	—	—	—	



BREMSEN BRAKES FREINS

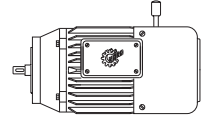

BREMSMOTOREN

Die im Katalog aufgeführten Motoren können durch Anbau einer Einscheiben-Federdruckbremse zu Bremsmotoren erweitert werden.

Folgende Kombinationen sind möglich:

BRAKE MOTORS

The motors listed in this catalogue can be modified to brake motors by adding a spring loaded single-disc brake.

Following combinations are possible:

MOTEURS - FREIN

Les moteurs mentionnés dans ce catalogue peuvent être transformés en moteurs-frein par adjonction d'un frein à ressorts de pression monodisque.

Les combinaisons suivantes sont possible:

Motorbaugröße Frame size Taille moteur	Verlängerung des Motor ca. Motor length extended by approx Allongement approx. du moteur	Bremsmoment (= Bremsgröße) Brake torque (= Brake size) Couple de freinage (= Taille du frein)						
		[mm]		[Nm]				
63 S + L	56	5	10					
71 S + L	58	5	10					
80 S	69	5	10	20				
80 L	69	5	10	20				
80 L/40	69		10	20				
90 S	75		10	20	40			
90 L	75		10	20	40			
90 L/40	75			20	40			
100 L	91			20	40	60		
100 L/40	91			20	40	60		
112 M	94			20	40	60		
132 S	107					60	100	
132 M	107					60	100	150
Mehrgewicht Add. weight net. Supplément de poids	ca. kg approx. kg approx. kg	1,0	1,5	2,5	4,0	6,0	9,0	15

Fettgedruckte Bremsmomente = Normalausführung
Bold printed brake torque = Standard items
Couples de freinage en caractères gras = exécution normale

Bestellbeispiel:
 Example for ordering:
 Exemple de commande:

SK 30 - 80 S/4 BRE 10

Wie aus der obenstehenden Tabelle ersichtlich, können jeweils Bremsen mit verschiedenen Bremsmomenten an eine Motorbaugröße angebaut werden.

Für den normalen Einsatzfall empfiehlt sich, Bremsen mit Bremsmomenten zu wählen, die dem 1,5 - 2fachen des Motor - Nennmomentes entsprechen.

Für besondere Einsatzfälle z.B. Hubwerke etc., kann eine Verstärkung bis zum 3fachen notwendig werden. Für andere Antriebe kann es sich empfehlen, die Bremsmomente herabzusetzen.

Bei hoher Schalthäufigkeit bzw. größeren Massen empfehlen wir, die Bremse entsprechend zu dimensionieren.

BREMSEN-ANSCHLUSSPANNUNGEN

Die Bremse wird durch das Zuführen der angegebenen Spannung gelüftet. Entweder wird die Bremse direkt an Gleichspannung angeschlossen oder eine Wechselspannung wird durch einen im Klemmkasten eingebauten Gleichrichter gleichgerichtet. Zur Anpassung an die gebräuchlichen Anschlußspannungen sind verschiedene Spulenausführungen möglich.

As can be seen from the above table each motor frame is available with various brake sizes.

For normal applications we recommend sizing the brake to 1,5 - 2 time, the rated torque of the motor.

For special applications e.g. lifting gear etc. it may be necessary to increase this to 3 times the rated torque of the motor.

For other drives it may be advisable to reduce the braking torque. If fairly large masses have to be braked, we recommend the use of brakes with sufficient capacity.

BRAKE CONNECTION VOLTAGE

The brake will be released by feeding the rated voltage. The brake is either connected directly to DC-Voltage or an AC-Voltage will be converted to DC through a rectifier in the terminal box. To adapt to common voltages various coils are available.

Comme illustré ci-dessus, il est possible d'équiper une même taille de moteur avec des freins ayant des couples de freinage différents.

Pour une utilisation normale le couple de freinage doit être 1,5 à 2 fois le couple moteur. Pour des utilisations spéciales (levage) il peut être nécessaire d'avoir un couple trois fois plus élevé.

Pour d'autres utilisations on peut conseiller de réduire le couple de freinage.

Lors qu'il y a freinage d'une masse importante ou des cadences de fonctionnement très élevées, nous préconisons de dimensionner largement les frein.

TENSION D'ALIMENTATION DU FREIN

Le frein est desserré quand la tension de commande indiquée est appliquée. Soit le frein est raccordé directement à une tension continue, soit une tension alternative est redressée par un redresseur incorporé dans la boîte à bornes du moteur. Différentes exécutions de bobines sont disponibles pour l'adaptation aux tensions d'alimentation courantes.

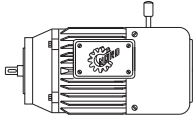

BREMSEN BRAKES FREINS



BESONDERE ABDICHTUNG GEGEN STAUB, SCHMUTZ UND FEUCHTIGKEIT

Für extreme Betriebsbedingungen mit Staub, Faserflug, Schmutz und Wassereinwirkung sowie Aussetzbetrieb in Verbindung mit Frost, können die Bremsen in folgenden Ausführungen geliefert werden.

- 1) Mit Staubschutzring (992)
- 2) Mit Reibscheibe aus rostfreiem Material (990)

Diese Ausführung empfehlen wir auch, wenn die Antriebe für einen längeren Zeitraum gelagert werden müssen.

- 3) Bremsen in der Schutzart IP 55 oder IP 66

Beide Ausführungen sind Sonderbremsen mit einer zusätzlichen Abdichtung zum Motorgehäuse.

Die Bremse IP 66 ist eine vollkommen geschlossene Bremse, die in drei Größen 4, 8 und 16 Nm angeboten wird. Bei der Schutzart IP 55 stehen vier Größen zur Verfügung, 5, 10, 20 und 40 Nm. Die Bremsmomentverstellung ist bei diesen Bremsen nur über die Anzahl der Federn möglich (kein Einstellring)

SPECIAL SEALS AGAINST DUST, DIRT AND MOISTURE

For extreme operating conditions with dust, fibre fly, dirt and water action and for periodic duty in conjunction with frost, the brake can be supplied as totally enclosed type (extra price on request).

- 1) Anti-dust ring (992)
- 2) Friction disc of anti-corrosive material (990)

We also recommend this version if the drives have to be stored for long periods.

- 3) Brakes with degree of protection IP 55 or IP 66

Both executions are special brakes with an additional sealing to the motor housing.

The brake IP 66 is a totally enclosed brake that is available in the sizes 4, 8 and 16 Nm. For the degree of protection, IP 55 four sizes are available 5, 10, 20 and 40 Nm. The adjustment of the brake torque is only possible by changing the quantity of the springs (no setting ring).

ETANCHEITE SPECIALE CONTRE POUSSIERE, SALETE, HUMIDITE

Pour des conditions d'utilisation extrêmes avec de la poussière, des fibres, des saletés, de l'eau ou des fonctionnements occasionnels en présence d'humidité, ou de risque de gel, nous préconisons des exécutions spécifiques pour le frein (nous consulter).

- 1) Bague de protection contre la poussière (992)
- 2) Disque de friction anti-corrosion (990)

Nous préconisons également cette exécution lorsque le matériel sera stocké de manière prolongée.

- 3) Freins avec degré de protection IP 55 ou IP 66

Ces deux exécutions nécessitent un frein spécial avec une étanchéité supplémentaire entre le frein et le flasque arrière.

Le frein IP 66 est un frein entièrement fermé qui est livrable en 3 tailles de 4, 8 et 16 Nm. Pour les degrés de protection IP 55, 4 tailles de frein 5, 10 et 40 Nm sont livrables. Le réglage des couples de freinage n'est possible qu'en jouant sur le nombre de ressorts du frein (aucune bague de réglage).

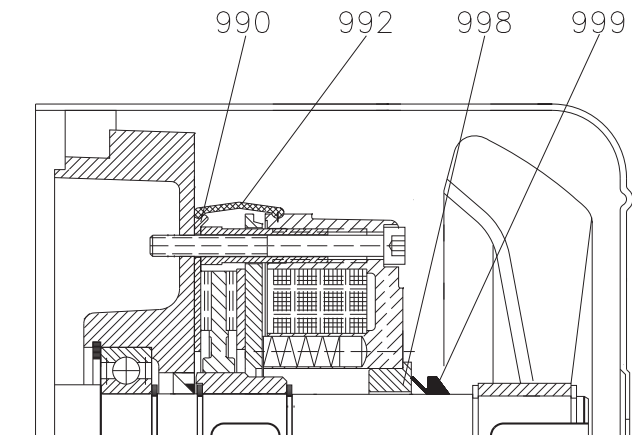

Bremse, Schutzart IP 55, für 5, 10, 20 und 40 Nm
Brake, Enclosure IP 55 for 5, 10, 20 and 40 Nm
Frein, protection IP 55 pour 5, 10, 20 et 40 Nm

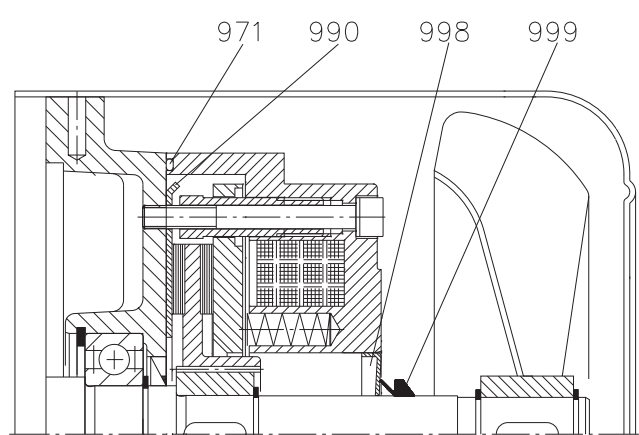

Bremse, Schutzart IP 66 für 4, 8 und 16 Nm
Brake, Enclosure IP 66 for 4, 8 and 16 Nm
Frein, protection IP 66 pour 4, 8 et 16 Nm

971 O - Ring
990 Reibblech
992 Staubschutzring **
998 Buchse / Dichtungslamelle
999 V - Ring

971 O - ring
990 friction plate
992 dust protection ring **
998 bushing / seal
999 V - Ring

971 Joint torique
990 Disque de friction
992 Anneau anti-poussière **
998 Lamelle d'étanchéité
999 Joint trapézoïdal

** nicht bei Bremse / not for brakes / pas pour les freins 20 Nm

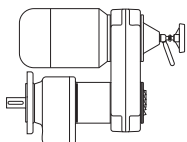

TECHNISCHE ERLÄUTERUNGEN EXPLANATORY NOTES DESCRIPTIONS TECHNIQUES

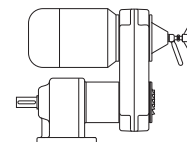

GETRIEBEAUSWAHL SELECTION PROCEDURE CHOIX DU REDUCTEUR

GETRIEBE UND MOTOR

Die in dem Getriebekatalog (G 2000, Stirnradgetriebe) aufgeführten technischen Erläuterungen, sowie die zulässigen Radial- und Axialbelastungen der Abtriebswelle, gelten auch für die Verstellgetriebemotoren.

Die eingebauten Verstell scheiben sind bewährte Elemente, die in Großserien gefertigt werden und für jede Einbaulage geeignet sind. Die Verstell scheiben sind wartungsfrei mit vollkommen passungsrostfreien Führungsbahnen ausgerüstet. Auch alle übrigen Komponenten sind aus korrosionsfesten Werkstoffen hergestellt und für wartungsfreien Betrieb ausgelegt.

Präzise und stabile Führungsbahnen garantieren eine lange Lebensdauer und ruhigen Lauf. Eine Druckfeder mit optimaler Kennlinie ist ein besonders wichtiges Bauelement für sichere Leistungsübertragung über den ganzen Verstellbereich. Die Verstell scheiben haben ein sehr kleines Massenträgheitsmoment durch Laufflächen aus hochabriebfestem Leichtmetall (wichtig für Reversier- und Stop-Betrieb). Die heutigen Hochleistungs-Keilriemen können in ihrem ganzen Leistungsspektrum voll genutzt werden. Der symmetrische Querschnitt und die gleichmäßige Flankenpressung garantieren optimale Leistungsübertragung bei hohem Wirkungsgrad mit langer Lebensdauer und hervorragenden Laufeigenschaften.

Die Breitkeilriemen sind serienmäßig elektrisch leitfähig. Sie haben eine formgeprägte Innenverzahnung bzw. Innen- und Außenverzahnung und sind extrem biegefreudig. Sie sind flankengeschliffen für besonders ruhigen Lauf!

GEARBOX AND MOTOR

The explanatory notes and permissible radial and axial loads on the output shaft given in the catalogue

(G 2000, Helical Gear Units) also apply to variable speed drives.

The built-in regulating pulleys are proven elements, produced in large series and operational in any position.

The regulating pulleys are maintenance free, i.e. they have been equipped with rustproof guides. All other components have also been manufactured from corrosion-proof material and prepared for maintenance free operation.

Precise and strong guides ensure a long operation-life and smooth running. The built-in spring with its optimized characteristic complete variation range. The pulleys have a low mass moment of inertia with surfaces of non-abrasive light-metal (important for reversing and inching operations).

Today's high capacity V-belts can be used to their full performance range. The symmetrical cross-section and constant axial pressure guarantees optimum power transmission with a high degree of efficiency, long working life and excellent running qualities.

As standard the V-belts are electrically conductive. They have a profiled inner-respectively, inner- and outer-contour and are very flexible. Both flanks are machined for smooth operation.

REDUCTEUR ET MOTEUR

Les descriptions techniques et les charges radiales et axiales admissibles sur l'arbre de sortie de réducteurs mentionnées dans notre catalogue

(G 2000, Réducteurs à engrenages cylindriques) sont également valables pour les motovariateurs. Les poulies variable utilisée sont d'une fiabilité parfaite, exécutées en grande série, convenant à toutes les positions de montage. Les poulies ne nécessitent aucun entretien, et sont équipées de gorges inoxydables. Les pulies ne nécessitent aucun entretien, et son équipées de gorges inoxydables. Les autres composants sont également en matière anticorrosive et ne demandent aucun entretien.

Des gorges précises et résistantes garantissent une longue durée de vie et un fonctionnement sans bruit. Un ressort de pression avec un guidage optimal est un des éléments importants pour garantir une bonne transmission de la puissance sur l'ensemble de la plage de réglage. Les poulies ont une inertie très faible grâce aux disques en alliage léger de haute qualité (important pour les mouvements réversible et arrêt). Les courroies fabriquées suivant les méthodes les plus modernes peuvent être utilisées sur tout leur spectre de puissance. La section symétrique et la pression régulière des flancs garantissent une transmission optimale de la puissance avec un bon rendement et une longue durée de vie.

Les courroies larges sont conçues des série, antistatiques. Elles sont crantées sur leur face interne ou sur la face externe et son très flexibles. Elles sont rectifiées latéralement pour assurer un fonctionnement silencieux.

ABMESSUNGEN FÜR KEILRIEMEN / V - BELT DIMENSIONS / DIMENSIONS DES COURROIES TRAPEZOIDALES

R 080	R 100	R 150	R 196	R 210
17x5x480 Li	22,5x7x578 Li	28x7x754 Li	33x9x906 Li	37x10x950 Li

AUSWAHL VON VERSTELLGETRIEBE - MOTOREN

Um einen Verstellgetriebemotor treffsicher auszuwählen, müssen die zu fahrenden Abtriebsdrehzahlen und die dabei abgenommenen Abtriebsdrehmomente bekannt sein, bzw. vorher ermittelt worden sein.

Verstellgetriebemotoren sind dann folgendermaßen auszuwählen:

- Die Nenn - Motorleistung P_n darf bei allen gefahrenen Abtriebsdrehzahlen n_2 und den dabei vorliegenden Abtriebsdrehmomenten M_2 nicht überschritten werden, d.h.:

$$\frac{M_2}{9550} \frac{n_2}{0,9} \leq P_n$$

Dies ist gewährleistet, wenn das in den Tabellen angegebene zulässige Abtriebsdrehmoment M_{a1} bei der höchsten Drehzahl n_{21} und das zulässige Abtriebsdrehmoment M_{a2} bei der niedrigsten Drehzahl n_{22} nicht überschritten wird, und bei dazwischenliegenden Drehzahlen die oben aufgeführte Gleichung erfüllt ist.

- Das in den Tabellen angegebene Abtriebsmoment M_{a2} darf grundsätzlich nicht überschritten werden.

SELECTION OF VARIABLE - SPEED - DRIVES (VSD)

To select a VSD correctly it is important to know or to calculate the required speed-range and the torque required across this speed-range.

The VSD is then selected as follows :

- The rated motor-power P_n must not be exceeded at any speed across the range and the resulting output torques M_2 i.e. :

$$\frac{M_2}{9550} \frac{n_2}{0,9} \leq P_n$$

This is achieved when the permissible output torque M_{a1} at the highest speed n_{21} and the permissible output torque M_{a2} at the lowest speed n_{22} given in the tables is not exceeded and the a.m. equation is fulfilled for the speeds inbetween.

- The output torque M_{a2} listed in the tables must never be exceeded.

CHOIX DES MOTORÉDUCTEURS - VARIATEURS

Pour choisir précisément un motoréducteur-variateur, il faut avoir eu connaissance des vitesses de sortie utilisées ainsi que des couples de sortie nécessaires.

Il faut procéder de la manière suivante :

- Pour toutes les vitesses de sortie utilisées n_2 et tous les couples correspondants M_2 disponibles, la puissance nominale du moteur P_n ne doit jamais être dépassée, c'est-à-dire :

$$\frac{M_2}{9550} \frac{n_2}{0,9} \leq P_n$$

Ceci est garanti, si le couple de sortie admissible M_{a1} donné pour la vitesse maxi n_{21} et le couple de sortie admissible M_{a2} donné pour la vitesse mini n_{22} ne sont pas dépassés, et si pour les vitesses intermédiaires l'équation ci-dessus est respectée.

- En principe le couple de sortie M_{a2} donné dans le tableau ne doit pas être dépassé.

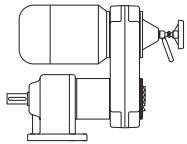

TECHNISCHE ERLÄUTERUNGEN EXPLANATORY NOTES DESCRIPTIONS TECHNIQUES

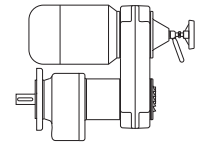

GETRIEBEAUSWAHL / VERSTELLUNGEN SELECTION PROCEDURES / SPEED CONTROLS CHOIX DU REDUCTEUR / REGLAGES

AUSWAHL VON VERSTELLGETRIEBE - MOTOREN

3. Der aufgrund der Belastungsart erforderliche Betriebsfaktor f_B wird mit Hilfe des Diagrammes auf Seite 3 bestimmt. Der Betriebsfaktor des ausgewählten Verstellgetriebemotors kennzeichnet die Sicherheit des Stirnradgetriebes, er muß mindestens so groß sein, wie der erforderliche Betriebsfaktor. Der Betriebsfaktor des ausgewählten Verstellgetriebemotors ist abhängig von der eingestellten Drehzahl. Er ist in den Tabellen bei der höchsten Drehzahl n_{21} als f_{B1} und bei der niedrigsten Drehzahl n_{22} als f_{B2} angegeben. Liegt die im Betrieb überwiegend gefahrene Drehzahl n_2 dazwischen, ist für diese Drehzahl n_2 der Betriebsfaktor f_B folgendermaßen zu bestimmen:

$$f_B = \frac{n_2}{n_{21}} \cdot f_{B1}$$

Zusätzlich gilt, daß der Betriebsfaktor f_{B2} die untere Grenze darstellt:

$$f_B \geq f_{B2}$$

Hinweis: Die Drehmomentwandlung des Riementriebes ermöglicht dem Motor bei niedrigen eingestellten Drehzahlen Abtriebsdrehmomente zu erzeugen, die bis zu 600% über dem zulässigen Abtriebsdrehmoment M_{a2} liegen können. Um das Stirnradgetriebe und den Riementrieb nicht zu überlasten, dürfen auch bei niedrigen Drehzahlen keine höheren Abtriebsdrehmomente als M_{a2} abgenommen werden. In speziellen Fällen ist die Auswahl von Getriebebau NORD zu prüfen. Wir bitten um Anfrage.

DREHZAHLEINSTELLUNG BEI HANDVERSTELLUNG

Bei der Einstellung des Verstellbereiches ist darauf zu achten, daß bei höchster Drehzahl (Verstellscheibe 506 geschlossen) die Stellmutter (512) so eingestellt wird, daß die Verstellscheibe (506) noch 0,5-1,0 mm Spiel aufweist, um ein Zerstören des Lagers in der Verstellscheibe (506) und der Lager im Motor zu vermeiden. Der Keilriemen darf nicht auf den Grund der Verstellscheibe (506) gezogen werden (Geräusche). Der Verstellbereich bei kleinster Drehzahl (Verstellscheibe 506 geöffnet) wird durch die Stellmutter 512a begrenzt.

Alle Positionen siehe Seite 96.

I. Zentralverstellung, Typ ZV

Falls keine anderslautende Bestellangabe erfolgt, werden alle Verstellgetriebemotoren mit Zentralverstellung nach Bild I, Type ZV geliefert.

Verstellung Typ ZV ist die Normalausführung!

SELECTION OF VARIABLE - SPEED - DRIVES (VSD)

3. The required safety factor f_B depending on the type of loading is determined according to the diagram on page 4. The service factor of the selected VSD refers to the safety of the helical-gearbox and it must be at least as high as the required safety factor. The safety factor of the selected VSD depends on the speed setting. This safety factor is listed in the tables as f_{B1} for the highest speed n_{21} and as f_{B2} for the lowest speed n_{22} . In case the speed mainly used lies inbetween it is possible to calculate the service factor for any given n_2 as follows :

$$f_B = \frac{n_2}{n_{21}} \cdot f_{B1}$$

In addition the safety factor f_{B2} is the lower limit :

$$f_B \geq f_{B2} \text{ must be fulfilled}$$

Note : The belt-variator acts as a torque multiplier for the motor which can result in torques of up to 600% of the permissible output torques M_{a2} at low speed settings. To avoid overloading the helical-gearbox and the belt-variator no higher torques than M_{a2} must be absorbed by the application even at low speeds. In special cases the selection should be verified by Getriebebau NORD. Please enquire.

SPEED ADJUSTING WITH MANUAL CONTROL

Take special care when positioning the lock nut (512) which limits the top speed (adjustable pulley closed). To prevent damage to the pulley and motor bearings this lock must be set so that the adjustable pulley has a gap of 0,5 to 1,0 mm. The V-belt should not be in contact with the bottom of the adjustable pulley (506). The lock nut (512 a) limits the lowest speed of the ratio range.

All positions see page 96.

I. Control gear, type ZV

Unless otherwise indicated all variable speed gear motors are supplied with a coaxial control acc. to figure. I, type ZV.

Control gear type ZV is the standard design!

CHOIX DES MOTORÉDUCTEURS - VARIATEURS

3. Le facteur de service f_B nécessaire en fonction des conditions de fonctionnement et de charge doit être défini à l'aide du diagramme page 4. Le facteur de service du motoréducteur-variateur retenu est déterminant pour le réducteur à engrenages cylindriques, il doit au moins être égal au facteur de service nécessaire. Le facteur de service dépend de la vitesse réglée. Dans les tableaux il est défini par f_{B1} pour la vitesse maxi n_{21} et par f_{B2} pour la vitesse mini n_{22} . Pour toutes les vitesses comprises dans cette plage, on déterminera le facteur de service de la manière suivante :

$$f_B = \frac{n_2}{n_{21}} \cdot f_{B1}$$

Il ne faut pas oublier que le facteur de service f_{B2} est la limite inférieure et que, par conséquent, il faut vérifier que :

$$f_B \geq f_{B2}$$

Recommandation: La variation de couple du variateur mécanique permet au moteur, pour les plus basses vitesses, de générer des couples de sortie allant jusqu'à 600 % au-delà de la valeur admissible M_{a2} du couple de sortie. Pour que le réducteur à engrenages cylindriques et le variateur mécanique ne soient pas surchargés, il faut en aucun cas que le couple de sortie pour les basses vitesses ne dépassent la valeur M_{a2} . Dans le cas contraire, nous vous demandons de bien vouloir nous consulter.

RÉGLAGE MANUEL DE LA VITESSE DE ROTATION

L'écrou de réglage (512) qui limite la plage de variation vers les vitesses élevées doit être de telle manière que le jeu entre roulement à billes et écrou de réglage soit de 0,5 à 1,0 mm lorsque les flasques de la poulie menante (506) sont rapprochés pour éviter la destruction du roulement dans la poulie menée et des roulements du moteur. L'écrou de réglage (512 a) limite la plage de variation vers les basses vitesses.

Voir toutes les positions page 96.

I. Réglage frontal, type ZV

Sans mention particulière définie sur la commande, tous les motovariateurs son livrés avec un dispositif de réglage frontal suivant la figure I, Type ZV.

Le volant de réglage type ZV est standard!

**Bild I
figure I**

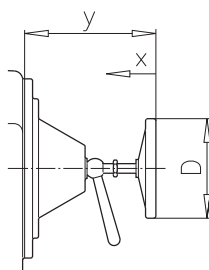

Typ Type Type	D	y	x	n
R 080	40	84	11,5	9,2
R 100	100	149	15,3	10,2
R 150	100	159	22,0	12,5
R 196	125	192	27,0	13,5
R 210	125	198	31,0	15,5

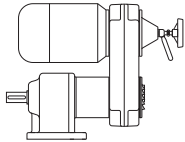

TECHNISCHE ERLÄUTERUNGEN EXPLANATORY NOTES DESCRIPTIONS TECHNIQUES

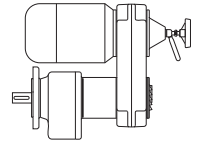

VERSTELLUNGEN SPEED CONTROLS REGLAGES

II. Winkelsteuerung, Typ WST

II. Angular control, type WST

II. Réglage angulaire, type WST

Bild II
figure II

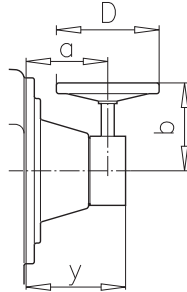

Typ Type Type	D	a	b	y	n
R 100	100	113	102	142	10
R 150	100	135	102	163	15
R 196	125	137	110	165	18
R 210	125	137	110	165	21

Um den gesamten Verstellbereich durchzufahren, sind die in den Tabellen aufgeführten Umdrehungen (n) notwendig.
Falls keine andere Bestellangabe erfolgt, wird die Verstellung wie abgebildet montiert.

To cover the entire speed range, the number of full turns of the handwheel as listed in the tables are required (n).
Unless otherwise indicated the control will be mounted as shown.

Le tableau ci-dessous indique le nombre de tours nécessaires pour parcourir la plage de réglage complète.
Sans autre indication le montage sera fait comme illustré.

SKALENHANDRÄDER

Die einfachste und preisgünstigste Lösung ist der Anbau eines Skalenhandrades. Skalenhandräder können an horizontale Spindeln und an Spindeln bis zu 60° Neigung gegen die Horizontale angebaut werden. Skalenhandräder sind auf Wunsch mit Ballengriff und in staub- oder wasserdichter Ausführung lieferbar. Die Skalen werden mit einer neutralen Teilung geliefert. Die Teilung ist abhängig von der Anzahl der notwendigen Handumdrehungen.

HANDWHEELS WITH SPEED INDICATING DIAL

The simplest and most economic solution is to fit a dial handwheel. Dial handwheels can be attached to horizontal spindles and spindles inclined by up to 60° to the horizontal. Dial handwheels are available optionally with a handle and in a dust- or waterproof version. The scales are supplied with neutral graduation. The graduation depends on the number of turns of the handwheel necessary.

VOLANT INDICATEUR

La solution la plus simple et la moins onéreuse est le montage d'un volant indicateur à main, soit en position horizontale, soit incliné jusqu'à 60°. Il est livrable étanche à la poussière et à l'eau, selon demande. Le cadran a une graduation neutre. La graduation est fonction du nombre de tours nécessaires.

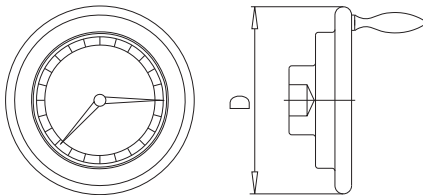

Typ Type Type	D	i
R 100	80	1:12
R 150	125	1:18
R 196	125	1:18
R 210	125	1:18

III. Elektromechanische Fernverstellung, Typ EMFST

kann an die Verstelleinheiten R 100 - R 210 angebaut werden. Bei dieser Ausführung handelt es sich um einen Schneckengetriebemotor mit Endschaltern.

III. Electromechanical remote control, type EMFST

can be attached to variator types R 100 - R 210. This version comprises a worm geared motor with limit switches.

III. Télé réglage électromécanique, type EMFST

peut être monté sur les variateurs R 100 - R 210. Cette exécution se compose d'un motoréducteur à roue et vis sans fin avec interrupteur fin de course.

KEILRIEMENWECHSEL

Extrem einfacher Keilriemenwechsel:

Zylinderschrauben (521) lösen und Abdeckhaube (501) mit kompletter Verstellung abnehmen. Keilriemen entfernen. Der neue Keilriemen wird zuerst um die geöffnete Verstelleiche (506) geschlungen und dann von Hand in die Federscheibe (507) gezogen. Bei geöffneter Verstelleiche (506) läßt sich der Riemen dann leicht einlegen. Niemals gewaltsam mit harten Hilfsmitteln versuchen, die Federscheibe zu öffnen.

Nach Ausführung dieser Arbeiten ist die Abdeckhaube (501) mit kompletter Verstellung wieder anzuschrauben.

Jeder neue Keilriemen längt sich leicht, erst nach einigen Betriebsstunden wird der volle Verstellbereich erzielt.

REPLACEMENT OF-V-BELT

Easy V-belt replacement:

Unscrew the socket head screws (521) and remove cover (501) together with the entire speed control. Remove V-belt. Wrap the new V-belt around the open adjustable pulley (506) and then slip it over the spring loaded pulley (507). The V-belt can be easily fitted if the adjustable pulley is opened. Please ensure that the spring loaded pulley is opened carefully.

After this operation the removed cover with complete speed control has to be re-assembled.

Every new V-belt may stretch slightly but after a few hours of operation the full range of variation is available.

REPLACEMENT DE LA COURROIE TRAPEZOIDALE

Extrême simple remplacement de la courroie trapézoïdale:

Retirer les vis (521) et enlever le carter de protection (501) avec le bloc de commande complet. Oter la courroie trapézoïdale. La nouvelle courroie doit être enroulée sur la poulie réglable (506), position ouverte, et ensuite la placer sur la poulie à ressort (507) en tirant dessus à la main. Lorsque les flasques de la poulie réglable sont écartées, la courroie se met facilement en place. Ne jamais forcer l'écartement des flasques de la poulie à ressort à l'aide d'outil. Cette opération effectuée, remettre en place le demi carter (501) avec le pot de réglage complet.

Toutes les nouvelles courroies se détendent et c'est seulement après quelques heures de fonctionnement que la plage de réglage maximum sera atteinte.

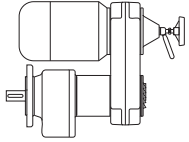

DREHZAHLANZEIGEN SPEED INDICATORS INDICATEURS DE VITESSE

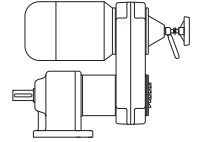

DREHZAHLANZEIGE SPEED INDICATOR INDICATEUR DE VITESSE

BERÜHRUNGSLOSE DREHZAHLANZEIGE

Typ: BLA - mit analogem Anzeigergerät
Typ: BLD - mit digitalem Anzeigergerät

NON CONTACTING SPEED INDICATOR

Type BLA - with analog indicator
Type BLD - with digital indicator

INDICATEUR DE VITESSE SANS CONTACT

Type BLA - avec unité d'affichage analog
Type BLD - avec unité d'affichage digital

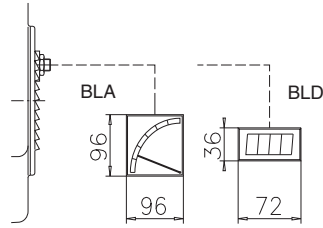

Typ BLA:

Der Drehzahlzeiger beinhaltet einen eingebauten, direkt angepaßten Meßumformer, der ein vom Impulsaufnehmer kommendes Signal in einen Gleichstrom umformt, der dem Meßwerk zugeführt wird. Ein Nachjustieren des Anzeigergerätes ist durch Einstellschrauben auf der Rückseite des Gerätes möglich.

Schutzart: IP 53 - Klemmen IP 00

Skalenbeschriftung: 0-100 %

Zeigerausschlag: 90°

Netzanschluß: 230 V, 50 Hz

Typ BLD:

Das digitale Anzeigergerät besitzt eine 4-stellige, rote 7-Segment-LED, 10 mm hoch. Die Hilfsspannung beträgt 230 V, 50 oder 60 Hz. Schutzart des Gehäuses IP50 - Klemmen IP00. Nach Abnahme der Frontplatte sind an der Gerätevorderseite einstellbar:

Zeitbasis, Vervielfachung, Kommastellung.

Falls keine andere Bestellangabe erfolgt, wird die Abtriebsdrehzahl in min^{-1} werkseitig eingestellt.

Typ BLA:

The speed indicator contains a built-in pulse sensor which converts the signals coming from the pulse generator into a direct current which is connected to the analog indicator.

Adjustment of the meter is possible by means of setting screws on the back of the meter.

Type of Enclosure: IP 53 - Terminals IP 00

Scale marking: 0-100 %

Scale deflection: 90°

Mains connection: 230 V, 50 Hz

Typ BLD:

The digital indicator has a 4 digit - 7 segment red LED display, 10 mm high.

The auxilliary voltage is 230 VAC, 50 Hz or 60 Hz.

Type of enclosure: IP 50 - Terminals IP 00. After taking off the front plate you can adjust: time base, duplication, comma. Unless otherwise indicated, output speed in min^{-1} is adjusted by factory!

Typ BLA:

L'indicateur de vitesse comprend un convertisseur de mesure incorporé et directement adapté qui transforme un signal courant coninu venant du capteur d'impulsions et le conduit à l'unité de mesure.

Il es possible d'ajuster cet indicateur à l'aide de vis situées sur le dos de l'appareil.

Protection: IP 53 - Bornes IP 00

Graduation: 0-100 %

Déviation indicateur: 90°

Raccordement réseau: 230 V, 50 Hz

Typ BLD:

L'unité d'affichage digital comprend un affichage LED de 4 chiffres à 7 segments et de 10 mm de hauteur. La tension auxiliaire est de 230 V, de 50 ou de 60 Hz.

Protection de carter: IP 50 - Bornes IP 00. Après enlèvement de la plaque de front il est possible régler: La base temporaire, multiplication, virgule.

S'il n'ya pas d'autres indications avec la commande la vitesse de sortie est ajustée en l'usine.

**STIRNRADGETRIEBE
HELICAL GEAR UNITS
REDUCTEURS A ENGRENAGES CYLINDRIQUES**

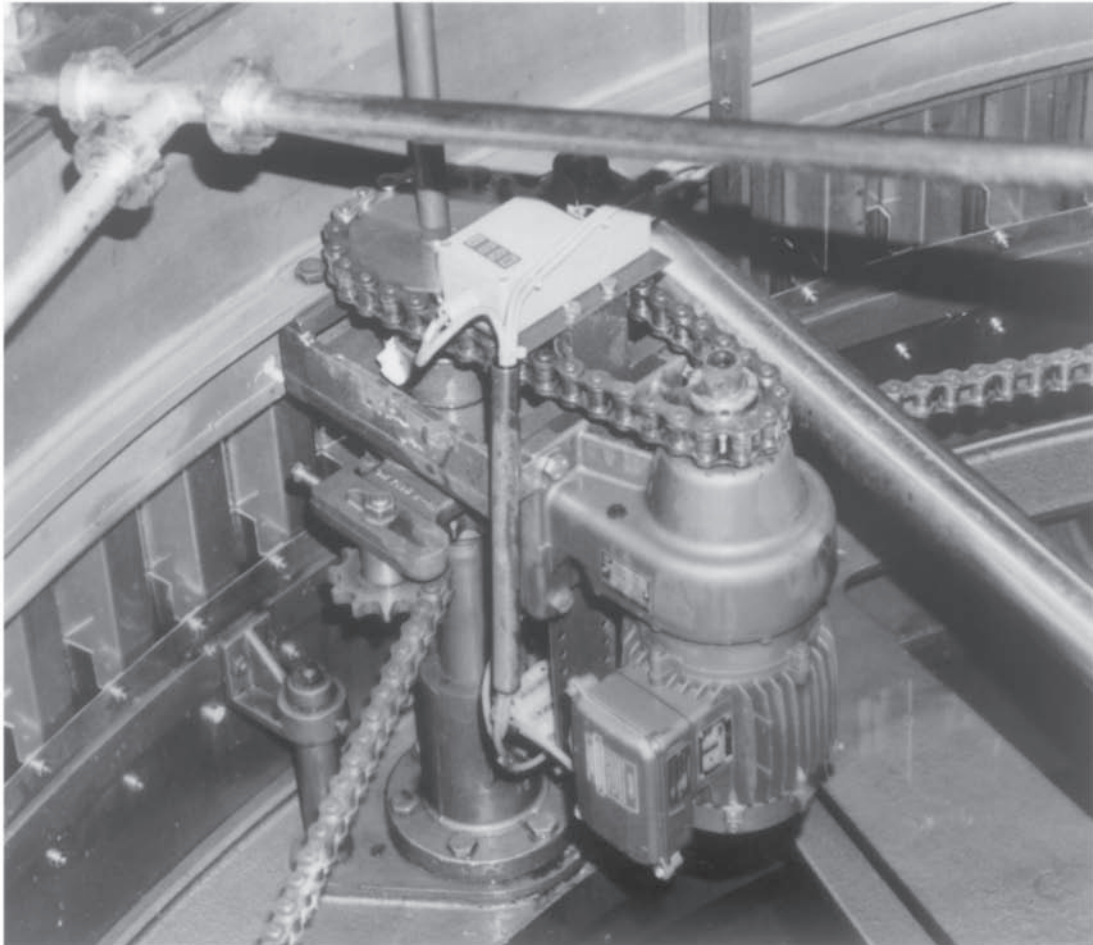

NORD-Stirnradtriebemotor als Antrieb eines Sortierwerkes
einer Verschleißmaschine in der Getränkeproduktion
NORD-helical geared motor as drive for a sorter-mechanism on a
capping-unit in the bottling industry
Motoréducteur à engrenages cylindriques NORD pour entraînement
d'une capsuleuse en sortie de machine d'embouteillage

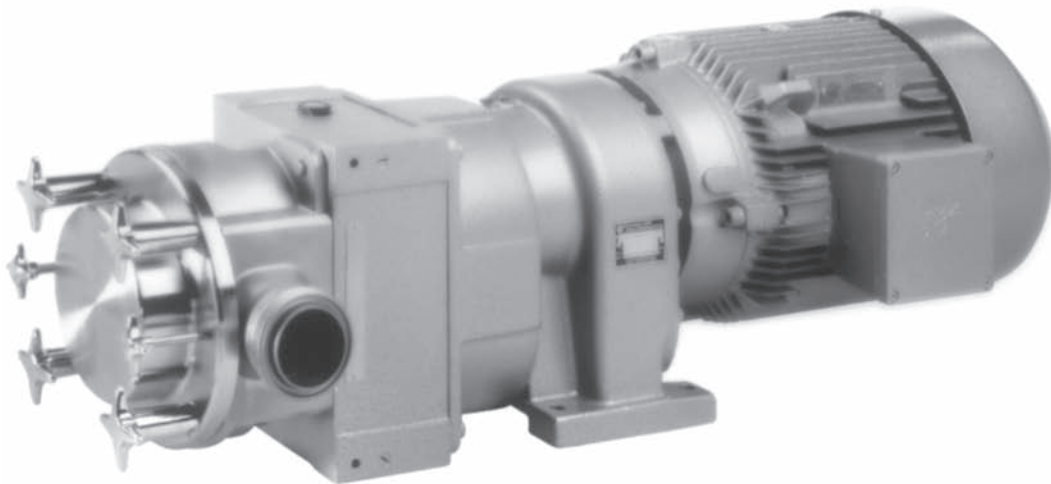

NORD-Stirnradtriebemotor als Antrieb einer Kreiskolbenpumpe
NORD-helical geared motor as drive for a disc-piston pump
NORD-Motoréducteur à engrenages cylindriques pour entraînement
d'une pompe à pistons rotatifs

TECHNISCHE ERLÄUTERUNGEN EXPLANATORY NOTES DESCRIPTIONS TECHNIQUES

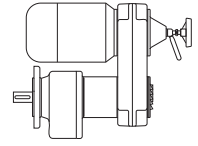
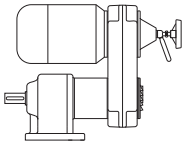

MOTORANBAU MOTOR ATTACHMENT MONTAGE MOTEURS

MOTORANBAU

Auf Wunsch können die Verstelltriebemotoren ohne Motor geliefert werden. (Wir empfehlen jedoch uns den Motor zum Anbau einzusenden, damit im Werk ein Probelauf durchgeführt werden kann.) Erforderliche Motorflansch- und Wellenabmessungen untenstehend.

Bei Anbau von IEC-Motoren ist zu beachten, daß das Maß x durch einen Distanzring ausgeglichen wird, um ein Schiefelaufen und somit vorzeitigen Riemenverschleiß zu vermeiden.

Zentrierung mit Gewinde nach DIN 332, Blatt 2.

MOTOR ATTACHMENT

Variable speed gear motors can also be supplied without motor on request (however, we recommend sending the motor to us for fitting, so that a trial run can be carried out at the factory). The necessary motor flange and shaft dimensions are shown below.

When fitting IEC-motors, it is important to adjust dimension x with a spacer in order to prevent off-track running and premature belt wear.

Tapped center hole to DIN 332, sheet 2.

MONTAGE MOTEURS

Les motovariateurs peuvent être livrés sans moteur. (Nous conseillons toutefois de nous adresser le moteur pour le montage en notre usine, nous permettant de faire un essai de fonctionnement. Dimensions des brides et bouts d'arbre moteur ci-dessous.

Lors du montage de moteurs IEC, il faut veiller à ce que les cotes x soient ajustées par l'intermédiaire d'une bague, afin d'éviter un montage décalé et une usure prématurée de la courroie.

Trous de centrage taraudés suivant DIN 332, feuille 2.

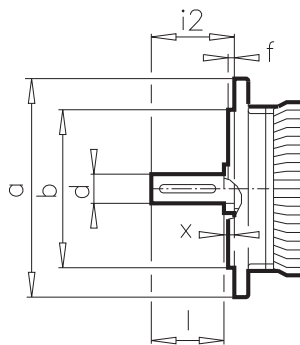

Motor / Moteur
90 - 112

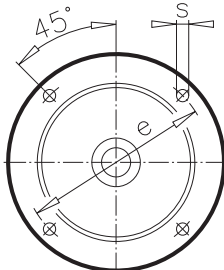
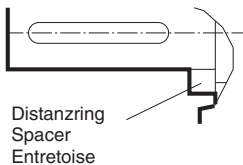

Motorabmessungen nach Werknorm Motor dimensions to works' standard Dimensions des moteurs selon norme usine										
Typ Type Type	Motor Motor Moteur	a	b	e	f	s	d	l	i2	x
R 080	71	105	70	85	2,5	M 6	14	44	44	-
R 100	80	105	70	85	2,5	M 6	18	40	48	-
R 100	90	120	80	100	3,0	M 6	18	40	48	-
R 150	90 - 100	160	110	130	3,5	M 8	24	50	58	-
R 196	100 - 112	200	130	165	3,5	M 10	28	60	69	-
R 210	132 S + M	200	130	165	3,5	M 10	28	60	69	-

Motortypen und Abmessungen bei Anbau von IEC-Normmotoren nach Motor types and dimensions to fitting of IEC standard motors acc. to Types du moteur et dimensions pour montage moteurs norme IEC selon DIN 42677										
Typ Type Type	Motor Motor Moteur	a	b	e	f	s	d	l	i2	x
R 150	90 S + L	200	130	165	3,5	Ø 11	24	50	58	8
R 196	100 - 112	250	180	215	4,0	Ø 11	28	60	60	9
R 210										

Zuordnungsübersicht Summary Résumé		
Typ Type Type	max. Motorleistung [kW] max. motor power [kW] puissance moteur, max. [kW]	Verstellbereich Ratio range Plage de réglage
R 080	0,37	5,0
R 100	1,50	5,0
R 150	3,00	6,5
R 196	4,00	8,0
R 210	7,50	7,5

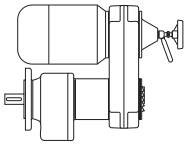

TECHNISCHE ERLÄUTERUNGEN EXPLANATORY NOTES DESCRIPTIONS TECHNIQUES

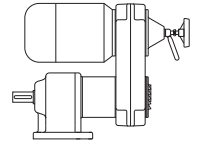

LIEFERBARE AUSFÜHRUNGEN, ANORDNUNG DES KLEMMKASTENS
AVAILABLE DESIGNS, POSITION OF TERMINAL BOX
EXECUTION LIVRABLES DISPOSITION DE LA BOITE A BORNES

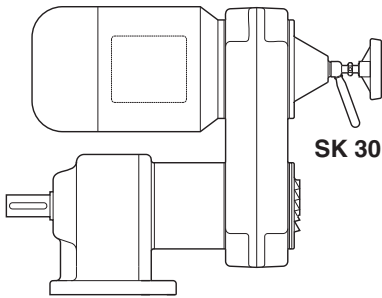

SK 30 - R 150 U - 100 L/4

NORMALAUSFÜHRUNG:

Stirnrad - Verstellgetriebemotor,
U-Ausführung (Typenzusatz **U**)
mit Zentralverstellung **ZV**

STANDARD TYPE:

Variable Speed Helical Geared Motor,
U design (affix **U**)
with control gear type **ZV**

EXECUTION NORMALE:

Motovariateur-réducteur à engrenages cylindriques ,
exécution U (suffixe **U**)
avec réglage frontal type **ZV**

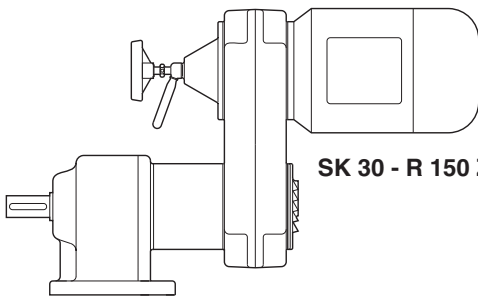

SK 30 - R 150 Z - 100 L/4

Stirnrad - Verstellgetriebemotor,
Z-Ausführung (Typenzusatz **Z**)
mit Zentralverstellung **ZV**

Variable Speed Helical Geared Motor,
Z design (affix **Z**)
with control gear type **ZV**

Motovariateur-réducteur à engrenages cylindriques ,
exécution Z (suffixe **Z**)
avec réglage frontal type **ZV**

**ANORDNUNG DES KLEMMKASTENS UND DER
KABELEINFÜHRUNG**

Lage des Klemmkastens und der Kabeleinführung
bitte angeben.

Normalausführung:
Klemmkasten bei 1, Kabeleinführung bei I.

Falls andere Anordnung gewünscht, bitte aus-
drücklichen Bestellhinweis.

**POSITION OF TERMINAL BOX AND CABLE
ENTRY**

Please specify position of terminal box and cable
entry.

Normal design:
Terminal box at 1, cable entry at I.

If other positions required, please specify exactly
when ordering.

**POSITION DE LA BOITE A BORNES ET DE
L'ENTREE DE CABLES**

Veillez indiquer la position de la boîte à bornes et
de l'entrée de câbles.

Exécution normale:
Boîte à bornes en 1, entrée de câbles en I.

Si une autre position est souhaitée, veuillez
l'indiquer lors de la commande.

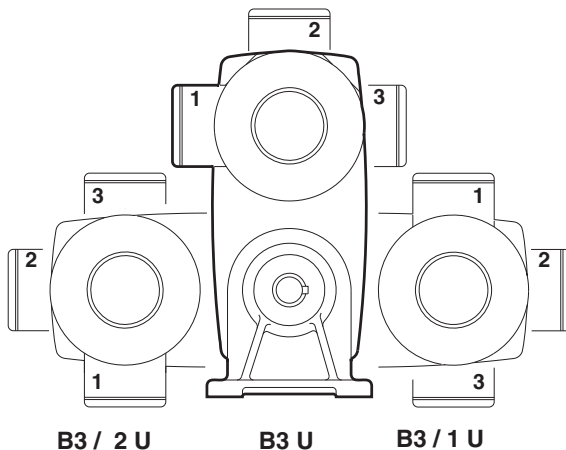

B3 / 2 U

B3 U

B3 / 1 U

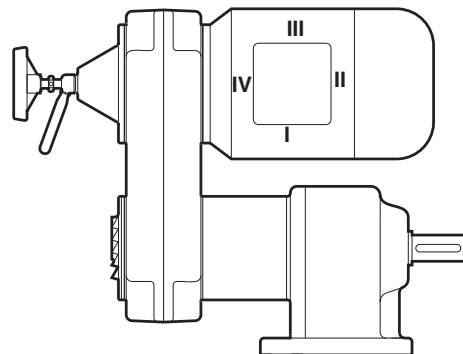

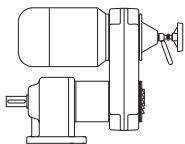

**TECHNISCHE ERLÄUTERUNGEN
EXPLANATORY NOTES
DESCRIPTIONS TECHNIQUES**

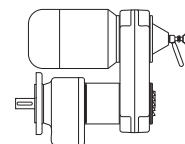

BAUFORMEN
MOUNTING POSITIONS
POSITIONS DE MONTAGE

Waagerechte Anordnung / Horizontal position / Position horizontale	
B 3 U (Z)	
B 6 U (Z)	
B 7 U (Z)	
B 8 U (Z)	
B 5 U (Z)	
B5a U (Z)	

Senkrechte Anordnung / Vertical position / Position verticale	
V 1 U (Z)	
V 3 U (Z)	
V 5 U (Z)	
V 6 U (Z)	



**STIRNRAD-VERSTELLGETRIEBEMOTOREN
VARIABLE SPEED HELICAL GEARED MOTORS
MOTORVARIATEURS-REDUCTEURS A ENGRENAGES CYLINDRIQUES**

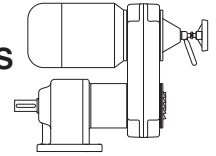

DREHSTROM
THREE PHASE
A COURANT TRIPHASE

P _n [kW]	n ₂₁ [min ⁻¹]	n ₂₂ [min ⁻¹]	M _{a1} [Nm]	M _{a2} [Nm]	f _{B1}	f _{B2}	i _{ges}	Typ Type Type	ca. kg	(400V)	i _{regel}	Maße Dimens. Cotes
										I _N [A]		
0.25	28	5.5	77.7	93.0	1.2	1.0	111.61	SK 01 - R080 U - 71S/4	19	0.99	5.00	88 - 89
	32	6.3	67.8	100	1.5	1.0	97.35					
	36	7.2	59.8	89.0	1.5	1.0	85.85					
	41	8.1	53.0	93.0	1.8	1.0	76.12					
	46	9.3	46.2	100	2.2	1.0	66.40					
	53	10.5	40.7	93.0	2.3	1.0	58.50					
	60	12.1	35.5	100	2.8	1.0	51.03					
	69	13.7	31.3	100	3.2	1.0	45.00					
	77	15.0	27.9	100	3.6	1.0	40.05					
	86	17	25.1	100	4.0	1.0	36.00					
	95	19	22.7	93.0	4.1	1.0	32.58					
	104	21	20.6	84.0	4.1	1.0	29.61					
	114	23	18.8	77.0	4.1	1.0	27.00					
	125	25	17.2	70.0	4.1	1.0	24.75					
	136	27	15.9	65.0	4.1	1.0	22.77					
	147	29	14.6	60.0	4.1	1.0	20.97					
	159	32	13.5	55.0	4.1	1.0	19.44					
	171	34	12.5	51.0	4.1	1.0	18.00					
	183	37	11.8	49.7	7.9	1.9	16.90					
	184	37	11.7	48.0	4.1	1.0	16.74					
	198	40	10.8	44.0	4.1	1.0	15.57					
	209	42	10.3	43.3	9.7	2.3	14.74					
	237	47	9.1	38.2	11.0	2.6	13.00					
	267	53	8.1	34.0	12.3	2.9	11.57					
	297	59	7.2	30.6	13.9	3.3	10.40					
	328	66	6.6	27.7	15.2	3.6	9.41					
	361	72	6.0	25.1	16.7	4.0	8.55					
	50	10.0	43.1	50.0	1.2	1.0	61.96	SK 0 - R080 U - 71S/4	16	0.99	5.00	88 - 89
	57	11.3	37.9	50.0	1.3	1.0	54.46					
	65	13.0	33.1	50.0	1.5	1.0	47.54					
	73	14.7	29.3	50.0	1.7	1.0	42.01					
	92	18	23.5	50.0	2.1	1.0	33.69					
	101	20	21.2	50.0	2.4	1.0	30.50					
	111	22	19.3	50.0	2.6	1.0	27.77					
	132	26	16.3	50.0	3.1	1.0	23.34					
	155	31	13.9	45.0	3.2	1.0	19.92					
	180	36	11.9	38.0	3.2	1.0	17.12					
	204	41	10.5	44.5	4.8	1.1	15.12					
	234	47	9.2	38.8	5.4	1.3	13.20					
	265	53	8.1	34.3	6.2	1.5	11.66					
	330	66	6.5	27.5	7.7	1.8	9.35					
	364	73	5.9	24.9	8.5	2.0	8.47					
	400	80	5.4	22.7	9.3	2.2	7.71					
	476	95	4.5	19.1	11.1	2.6	6.48					
	558	112	3.9	16.3	12.8	3.1	5.53					
	650	130	3.3	14.0	14.8	3.5	4.75					
	692	138	3.1	13.1	16.1	3.8	4.46					
	764	153	2.8	11.9	17.9	4.2	4.04					
839	168	2.6	10.8	19.2	4.6	3.68						
999	200	2.2	9.1	22.7	5.5	3.09						
0.37	40	8.0	79.6	93.0	1.2	1.0	76.12	SK 01 - R080 U - 71L/4	20	1.10	5.00	88 - 89
	46	9.2	69.4	100	1.4	1.0	66.40					
	52	10.4	61.2	93.0	1.5	1.0	58.50					
	60	11.9	53.4	100	1.9	1.0	51.03					
	68	13.5	47.1	100	2.1	1.0	45.00					
	76	15.0	41.9	100	2.4	1.0	40.05					
	84	17	37.6	100	2.7	1.0	36.00					
	93	19	34.1	93.0	2.7	1.0	32.58					
	103	21	31.0	84.0	2.7	1.0	29.61					
	113	23	28.2	77.0	2.7	1.0	27.00					
	123	25	25.9	70.0	2.7	1.0	24.75					
	134	27	23.8	65.0	2.7	1.0	22.77					
	145	29	21.9	60.0	2.7	1.0	20.97					
	156	31	20.3	55.0	2.7	1.0	19.44					
	169	34	18.8	51.0	2.7	1.0	18.00					
	180	36	17.7	50.4	5.3	1.8	16.90					
	182	36	17.5	48.0	2.7	1.0	16.74					
195	39	16.3	44.0	2.7	1.0	15.57						
206	41	15.4	44.0	6.5	2.3	14.74						

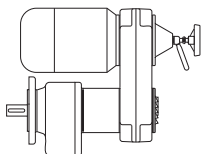

STIRNRAD-VERSTELLGETRIEBEMOTOREN
VARIABLE SPEED HELICAL GEARED MOTORS
MOTORVARIATEURS-REDUCTEURS A ENGRENAGES CYLINDRIQUES



DREHSTROM
 THREE PHASE
 A COURANT TRIPHASE

P _n [kW]	n ₂₁ [min ⁻¹]	n ₂₂ [min ⁻¹]	M _{a1} [Nm]	M _{a2} [Nm]	f _{B1}	f _{B2}	i _{ges}	Typ Type Type	ca. kg	(400V)	i _{regel}	Maße Dimens. Cotes					
										I _N [A]							
0.37	234	47	13.6	38.8	7.4	2.6	13.00	SK 01 - R080 U - 71L/4	20	1.10	5.00	88 - 89					
	263	53	12.1	34.5	8.3	2.9	11.57										
	292	58	10.9	31.0	9.2	3.2	10.40										
	323	65	9.8	28.1	10.2	3.6	9.41										
	356	71	8.9	25.5	11.2	3.9	8.55										
	72	14.5	43.9	50.0	1.1	1.0	42.01	SK 0 - R080 U - 71L/4	17	1.10	5.00	88 - 89					
	90	18	35.2	50.0	1.4	1.0	33.69										
	100	20	31.9	50.0	1.6	1.0	30.50										
	110	22	29.0	50.0	1.7	1.0	27.77										
	130	26	24.4	50.0	2.0	1.0	23.34										
	153	31	20.8	45.0	2.2	1.0	19.92										
	178	36	17.9	38.0	2.1	1.0	17.12										
	201	40	15.8	45.1	3.2	1.1	15.12										
	230	46	13.8	39.4	3.6	1.3	13.20										
	261	52	12.2	34.8	4.1	1.4	11.66										
325	65	9.8	27.9	5.1	1.8	9.35											
359	72	8.9	25.3	5.6	2.0	8.47											
394	79	8.1	23.0	6.2	2.2	7.71											
469	94	6.8	19.3	7.4	2.6	6.48											
550	110	5.8	16.5	8.6	3.0	5.53											
640	128	5.0	14.2	9.8	3.5	4.75											
682	136	4.7	13.3	10.6	3.8	4.46											
753	151	4.2	12.1	11.9	4.1	4.04											
826	165	3.8	11.0	13.2	4.5	3.68											
984	197	3.2	9.2	15.6	5.4	3.09											
0.55	43	8.5	111	386	3.5	1.0	72.10	SK 30 - R100 U - 80S/4	36	1.42	5.00	88 - 89					
	48	9.6	98.2	400	4.1	1.0	63.86										
	54	10.8	87.9	400	4.6	1.0	57.17										
	60	11.9	79.2	335	4.2	1.0	51.50										
	64	12.9	73.3	367	5.5	1.1	47.68										
	72	14.4	65.6	328	6.1	1.2	42.68										
	88	18	53.7	268	7.4	1.5	34.91										
	105	21	44.9	225	8.9	1.8	29.22										
	124	25	38.3	191	9.6	1.9	24.89										
	143	29	33.0	165	9.6	1.9	21.46										
	154	31	30.8	154	9.6	1.9	20.00										
	57	11.3	83.4	253	3.0	1.0	54.23						SK 25 - R100 U - 80S/4	34	1.42	5.00	88 - 89
	65	13.0	72.7	300	4.1	1.0	47.26										
	74	14.8	64.0	300	4.7	1.0	41.65										
	83	17	57.0	285	5.3	1.1	37.06										
92	18	51.2	256	5.7	1.1	33.32											
101	20	46.9	235	6.4	1.3	30.53											
113	23	41.8	209	7.2	1.4	27.16											
126	25	37.5	188	8.0	1.6	24.42											
154	31	30.8	154	9.7	1.9	20.00											
175	35	27.1	135	9.3	1.9	17.61											
200	40	23.6	118	12.7	2.5	15.35											
227	45	20.8	104	14.4	2.9	13.52											
40	8.0	118	200	1.7	1.0	76.50	SK 20 - R100 U - 80S/4	29	1.42	5.00	88 - 89						
46	9.2	102	200	2.0	1.0	66.56											
50	10.0	95.0	200	2.1	1.0	61.80											
57	11.4	82.7	200	2.4	1.0	53.77											
65	13.0	72.8	200	2.7	1.0	47.38											
73	14.6	64.8	200	3.1	1.0	42.13											
81	16	58.1	200	3.4	1.0	37.80											
90	18	52.4	197	3.8	1.0	34.09											
100	20	47.5	179	3.8	1.0	30.90											
109	22	43.2	163	3.8	1.0	28.12											
119	24	39.6	149	3.8	1.0	25.75											
130	26	36.3	137	3.8	1.0	23.59											
146	29	32.5	162	5.8	1.2	21.12											
167	33	28.2	141	6.5	1.3	18.37											
190	38	24.9	124	7.3	1.5	16.19											
238	48	19.9	99.3	9.1	1.8	12.92											



**STIRNRAD-VERSTELLGETRIEBEMOTOREN
VARIABLE SPEED HELICAL GEARED MOTORS
MOTORVARIATEURS-REDUCTEURS A ENGRENAGES CYLINDRIQUES**

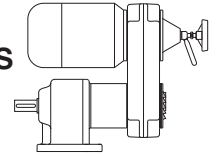

DREHSTROM
THREE PHASE
A COURANT TRIPHASE

P _n [kW]	n ₂₁ [min ⁻¹]	n ₂₂ [min ⁻¹]	M _{a1} [Nm]	M _{a2} [Nm]	f _{B1}	f _{B2}	i _{ges}	Typ Type Type	ca. kg	(400V) I _N [A]	i _{regel}	Maße Dimens. Cotes						
0.55	291	58	16.2	81.2	10.1	2.0	10.56	SK 20 - R100 U - 80S/4	29	1.42	5.00	88 - 89						
	349	70	13.5	67.7	10.1	2.0	8.80											
	414	83	11.4	57.1	10.1	2.0	7.43											
	448	90	10.5	52.7	10.1	2.0	6.86											
	60	12.1	78.5	100	1.3	1.0	51.03	SK 01 - R100 U - 80S/4	26	1.42	5.00	88 - 89						
	68	13.7	69.2	100	1.4	1.0	45.00											
	77	15.0	61.6	100	1.6	1.0	40.05											
	85	17	55.4	100	1.8	1.0	36.00											
	94	19	50.1	93.0	1.9	1.0	32.58											
	104	21	45.5	84.0	1.8	1.0	29.61											
	114	23	41.5	77.0	1.9	1.0	27.00											
	135	27	35.0	65.0	1.9	1.0	22.77											
	158	32	29.9	55.0	1.8	1.0	19.44											
	182	36	26.0	100	3.6	0.9	16.90											
	209	42	22.7	100	4.4	1.0	14.74											
	237	47	20.0	99.9	5.0	1.0	13.00											
	266	53	17.8	88.9	5.6	1.1	11.57											
	296	59	16.0	80.0	6.2	1.2	10.40											
	327	65	14.5	72.3	6.9	1.4	9.41											
	394	79	12.0	60.0	8.3	1.7	7.80											
	467	93	10.1	50.6	9.8	2.0	6.58											
	547	109	8.6	43.2	9.9	2.0	5.62											
	635	127	7.4	37.2	9.9	2.0	4.84											
	713	143	6.6	33.1	13.6	2.7	4.31											
854	171	5.5	27.7	13.6	2.7	3.60												
1008	202	4.7	23.4	13.4	2.7	3.05												
0.75	43	8.5	151	386	2.6	1.0	72.10	SK 30 - R100 U - 80L/4	38	1.87	5.00	88 - 89						
	48	9.6	134	400	3.0	1.0	63.86											
	54	10.8	120	400	3.3	1.0	57.17											
	60	11.9	108	335	3.1	1.0	51.50											
	72	14.4	89.5	400	4.5	1.0	42.68											
	88	18	73.2	331	5.5	1.2	34.91											
	105	21	61.3	277	6.5	1.4	29.22											
	124	25	52.2	236	7.0	1.6	24.89											
	143	29	45.0	203	7.0	1.6	21.46											
	154	31	41.9	189	7.0	1.6	20.00											
	182	36	35.4	160	11.0	2.4	16.87											
		57	11.3	114	253	2.2	1.0						54.23	SK 25 - R100 U - 80L/4	36	1.87	5.00	88 - 89
65		13.0	99.1	300	3.0	1.0	47.26											
74		14.8	87.3	300	3.4	1.0	41.65											
83		17	77.7	300	3.9	1.0	37.06											
92		18	69.9	293	4.2	1.0	33.32											
101		20	64.0	289	4.7	1.0	30.53											
113		23	56.9	257	5.3	1.2	27.16											
126		25	51.2	231	5.9	1.3	24.42											
154		31	41.9	189	7.2	1.6	20.00											
175		35	36.9	167	6.8	1.5	17.61											
200		40	32.2	145	9.3	2.1	15.35											
256		51	25.2	114	11.9	2.6	12.03											
315		63	20.5	92.6	14.6	3.2	9.77											
380		76	17.0	76.6	15.6	3.5	8.09											
		40	8.0	160	200	1.2	1.0	76.50	SK 20 - R100 U - 80L/4	31	1.87	5.00	88 - 89					
		46	9.2	140	200	1.4	1.0	66.56										
	50	10.0	130	200	1.5	1.0	61.80											
	57	11.4	113	200	1.8	1.0	53.77											
	65	13.0	99.3	200	2.0	1.0	47.38											
	73	14.6	88.3	200	2.3	1.0	42.13											
	81	16	79.3	200	2.5	1.0	37.80											
	90	18	71.5	197	2.8	1.0	34.09											
	100	20	64.8	179	2.8	1.0	30.90											
	109	22	59.0	163	2.8	1.0	28.12											
	119	24	54.0	149	2.8	1.0	25.75											
	130	26	49.5	137	2.8	1.0	23.59											
	146	29	44.3	200	4.2	0.9	21.12											
	166	33	38.9	107	2.8	1.0	18.54											
	190	38	33.9	153	5.4	1.2	16.19											

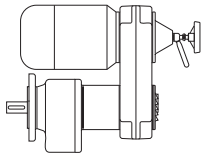

STIRNRAD-VERSTELLGETRIEBEMOTOREN
VARIABLE SPEED HELICAL GEARED MOTORS
MOTORVARIATEURS-REDUCTEURS A ENGRENAGES CYLINDRIQUES



DREHSTROM
 THREE PHASE
 A COURANT TRIPHASE

P _n [kW]	n ₂₁ [min ⁻¹]	n ₂₂ [min ⁻¹]	M _{a1} [Nm]	M _{a2} [Nm]	f _{B1}	f _{B2}	i _{ges}	Typ Type Type	ca. kg	(400V)	i _{regel}	Maße Dimens. Cotes	
										I _N [A]			
0.75	238	48	27.1	122	6.7	1.5	12.92	SK 20 - R100 U - 80L/4	31	1.87	5.00	88 - 89	
	291	58	22.1	100	7.4	1.6	10.56						
	349	70	18.5	83.4	7.4	1.6	8.80						
	414	83	15.6	70.4	7.4	1.6	7.43						
	448	90	14.4	65.0	7.4	1.6	6.86						
	485	97	13.3	60.1	7.4	1.6	6.34						
	530	106	12.2	54.9	10.9	2.4	5.80						
	665	133	9.7	43.8	11.3	2.5	4.62						
	68	13.7	94.3	100	1.1	1.0	45.00						
	77	15.0	84.0	100	1.2	1.0	40.05						
	85	17	75.5	100	1.3	1.0	36.00						
	94	19	68.3	93.0	1.4	1.0	32.58						
	104	21	62.1	84.0	1.4	1.0	29.61						
	114	23	56.6	77.0	1.4	1.0	27.00						
	135	27	47.7	65.0	1.4	1.0	22.77						
	158	32	40.8	55.0	1.3	1.0	19.44						
	171	34	37.7	51.0	1.4	1.0	18.00						
	182	36	35.4	100	2.6	0.9	16.90						
	209	42	30.9	100	3.2	1.0	14.74						
237	47	27.3	100	3.7	1.0	13.00							
266	53	24.3	100	4.1	1.0	11.57							
296	59	21.8	98.5	4.6	1.0	10.40							
327	65	19.7	89.1	5.1	1.1	9.41							
394	79	16.4	73.9	6.1	1.4	7.80							
467	93	13.8	62.3	7.2	1.6	6.58							
547	109	11.8	53.2	7.2	1.6	5.62							
635	127	10.1	45.9	7.2	1.6	4.84							
713	143	9.0	40.8	10.0	2.2	4.31							
854	171	7.5	34.1	10.0	2.2	3.60							
1008	202	6.4	28.9	9.8	2.2	3.05							
1.10	45	8.9	212	386	1.8	1.0	72.10	SK 30 - R100 Z - 90S/4	40	2.75	5.00	90 - 91	
	50	10.0	188	400	2.1	1.0	63.86						
	56	11.2	168	400	2.4	1.0	57.17						
	62	12.5	152	335	2.2	1.0	51.50						
	67	13.5	140	400	2.9	1.0	47.68						
	75	15.0	126	387	3.2	1.0	42.68						
	83	17	113	335	3.0	1.0	38.45						
	92	18	103	317	3.9	1.3	34.91						
	110	22	86.1	265	4.6	1.5	29.22						
	129	26	73.3	226	5.0	1.6	24.89						
	150	30	63.2	195	5.0	1.6	21.46						
	160	32	58.9	182	5.0	1.6	20.00						
	190	38	49.7	153	7.8	2.5	16.87						
	59	11.8	160	253	1.6	1.0	54.23						
	68	13.6	139	300	2.2	1.0	47.26						
	77	15.0	123	300	2.4	1.0	41.65						
	87	17	109	300	2.8	1.0	37.06						
	96	19	98.2	293	3.0	1.0	33.32						
	105	21	90.0	277	3.3	1.1	30.53						
	118	24	80.0	247	3.8	1.2	27.16						
	131	26	72.0	222	4.2	1.4	24.42						
	146	29	65.0	200	4.6	1.5	22.05						
	160	32	58.9	182	5.1	1.6	20.00						
	182	36	51.9	160	4.8	1.6	17.61						
	209	42	45.2	139	6.6	2.2	15.35						
	267	53	35.4	109	8.5	2.8	12.03						
	328	66	28.8	88.7	10.4	3.4	9.77						
	397	79	23.8	73.4	11.2	3.6	8.09						
	470	94	20.1	61.9	11.1	3.6	6.82						
	510	102	18.5	57.1	11.2	3.6	6.29						
		52	10.4	182	200	1.1	1.0	61.80	SK 20 - R100 U - 90S/4	33	2.75	5.00	88 - 89
		60	11.9	158	200	1.3	1.0	53.77					
		68	13.5	140	200	1.4	1.0	47.38					
	76	15.0	124	200	1.6	1.0	42.13						
	85	17	111	200	1.8	1.0	37.80						



**STIRNRAD-VERSTELLGETRIEBEMOTOREN
VARIABLE SPEED HELICAL GEARED MOTORS
MOTORVARIATEURS-REDUCTEURS A ENGRENAGES CYLINDRIQUES**

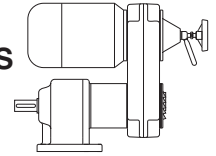

DREHSTROM
THREE PHASE
A COURANT TRIPHASE

P _n [kW]	n ₂₁ [min ⁻¹]	n ₂₂ [min ⁻¹]	M _{a1} [Nm]	M _{a2} [Nm]	f _{B1}	f _{B2}	i _{ges}	Typ Type Type	ca. kg	(400V) I _N [A]	i _{regel}	Maße Dimens. Cotes						
1.10	94	19	100	197	2.0	1.0	34.09	SK 20 - R100 U - 90S/4	33	2.75	5.00	88 - 89						
	104	21	91.0	179	2.0	1.0	30.90											
	114	23	82.9	163	2.0	1.0	28.12											
	125	25	75.9	149	2.0	1.0	25.75											
	136	27	69.5	137	2.0	1.0	23.59											
	152	30	62.2	192	3.0	1.0	21.12											
	175	35	54.1	167	3.4	1.1	18.37											
	198	40	47.7	147	3.8	1.2	16.19											
	248	50	38.1	117	4.8	1.6	12.92											
	304	61	31.1	95.9	5.3	1.7	10.56											
	365	73	25.9	79.9	5.3	1.7	8.80											
	432	86	21.9	67.4	5.3	1.7	7.43											
	468	94	20.2	62.3	5.2	1.7	6.86											
	506	101	18.7	57.6	5.2	1.7	6.34											
	553	111	17.1	52.6	7.8	2.5	5.80											
	695	139	13.6	41.9	8.1	2.6	4.62											
		103	21	91.9	100	1.1	1.0						31.20	SK 01 V - R100 U - 90S/4	30	2.75	5.00	88 - 89
114		23	83.2	100	1.2	1.0	28.24											
125		25	75.6	100	1.3	1.0	25.66											
137		27	68.9	100	1.5	1.0	23.40											
150		30	63.2	100	1.6	1.0	21.45											
163		33	58.1	93.0	1.6	1.0	19.73											
177		35	53.5	86.0	1.6	1.0	18.17											
	190	38	49.8	100	1.9	0.9	16.90	SK 01 - R100 U - 90S/4	30	2.75	5.00	88 - 89						
	218	44	43.4	100	2.3	1.0	14.74											
	247	49	38.3	100	2.6	1.0	13.00											
	277	55	34.1	100	2.9	1.0	11.57											
	309	62	30.6	94.4	3.3	1.1	10.40											
	341	68	27.7	85.4	3.6	1.2	9.41											
	411	82	23.0	70.8	4.3	1.4	7.80											
	488	98	19.4	59.7	5.1	1.7	6.58											
	571	114	16.6	51.0	5.1	1.7	5.62											
	663	133	14.3	43.9	5.1	1.7	4.84											
	744	149	12.7	39.1	7.1	2.3	4.31											
	891	178	10.6	32.7	7.1	2.3	3.60											
	969	194	9.8	30.0	7.0	2.3	3.31											
	1.50	44	8.8	294	386	1.3	1.0						72.10	SK 30 - R100 Z - 90L/4	44	3.60	5.00	90 - 91
50		9.9	260	400	1.5	1.0	63.86											
55		11.1	233	400	1.7	1.0	57.17											
61		12.3	210	335	1.6	1.0	51.50											
66		13.3	194	400	2.1	1.0	47.68											
74		14.8	174	393	2.3	1.0	42.68											
82		16	157	335	2.1	1.0	38.45											
91		18	142	321	2.8	1.2	34.91											
108		22	119	269	3.4	1.5	29.22											
127		25	101	229	3.6	1.6	24.89											
147		29	87.4	198	3.6	1.6	21.46											
158		32	81.5	184	3.6	1.6	20.00											
188		38	68.7	155	5.7	2.5	16.87											
		58	11.7	221	253	1.1	1.0	54.23	SK 25 - R100 Z - 90L/4	42	3.60	5.00	90 - 91					
		67	13.4	193	300	1.6	1.0	47.26										
		76	15.0	170	300	1.8	1.0	41.65										
		85	17	151	300	2.0	1.0	37.06										
	95	19	136	293	2.2	1.0	33.32											
	104	21	124	281	2.4	1.1	30.53											
	116	23	111	250	2.7	1.2	27.16											
	130	26	99.5	225	3.0	1.3	24.42											
	143	29	89.8	203	3.3	1.5	22.05											
	158	32	81.5	184	3.7	1.6	20.00											
	180	36	71.8	162	3.5	1.5	17.61											
	206	41	62.5	141	4.8	2.1	15.35											
	263	53	49.0	111	6.1	2.7	12.03											
	324	65	39.8	89.9	7.5	3.3	9.77											
	391	78	33.0	74.5	8.1	3.6	8.09											
	464	93	27.8	62.8	8.1	3.6	6.82											
	503	101	25.6	57.9	8.1	3.6	6.29											

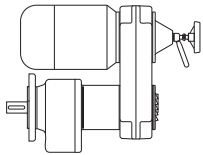

**STIRNRAD-VERSTELLGETRIEBEMOTOREN
VARIABLE SPEED HELICAL GEARED MOTORS
MOTORVARIATEURS-REDUCTEURS A ENGRENAGES CYLINDRIQUES**



DREHSTROM
THREE PHASE
A COURANT TRIPHASE

P _n [kW]	n ₂₁ [min ⁻¹]	n ₂₂ [min ⁻¹]	M _{a1} [Nm]	M _{a2} [Nm]	f _{B1}	f _{B2}	i _{ges}	Typ Type Type	ca. kg	(400V)	i _{regel}	Maße Dimens. Cotes						
										I _N [A]								
1.50	76	15.0	170	200	1.2	1.0	41.76	SK 20 V - R100 U - 90L/4	40	3.60	5.00	88 - 89						
	86	17	150	200	1.3	1.0	36.80											
	97	19	133	200	1.5	1.0	32.72											
	102	20	126	200	1.6	1.0	30.90											
	108	22	120	200	1.7	1.0	29.33											
	116	23	111	200	1.8	1.0	27.23											
	120	24	108	200	1.9	1.0	26.46											
	131	26	98.6	200	2.0	1.0	24.21											
		150	30	86.1	194	2.2	1.0						21.12	SK 20 - R100 U - 90L/4	37	3.60	5.00	88 - 89
		172	34	74.9	169	2.5	1.1						18.37					
195		39	66.0	149	2.8	1.2	16.19											
245		49	52.6	119	3.5	1.5	12.92											
300		60	43.0	97.2	3.8	1.7	10.56											
360		72	35.9	81.0	3.8	1.7	8.80											
426		85	30.3	68.4	3.8	1.7	7.43											
461		92	28.0	63.2	3.8	1.7	6.86											
499		100	25.8	58.4	3.8	1.7	6.34											
546		109	23.6	53.4	5.6	2.5	5.80											
685		137	18.8	42.5	5.9	2.6	4.62											
		148	30	87.4	100	1.1	1.0	21.45	SK 01 V - R100 U - 90L/4	34	3.60	5.00	88 - 89					
		160	32	80.4	93.0	1.2	1.0	19.73										
		174	35	74.0	86.0	1.2	1.0	18.17										
	187	37	68.9	100	1.3	0.9	16.90	SK 01 - R100 U - 90L/4	34	3.60	5.00	88 - 89						
	215	43	60.1	100	1.7	1.0	14.74											
	243	49	53.0	100	1.9	1.0	13.00											
	273	55	47.1	100	2.1	1.0	11.57											
	304	61	42.4	95.7	2.4	1.0	10.40											
	336	67	38.3	86.6	2.6	1.2	9.41											
	406	81	31.8	71.8	3.1	1.4	7.80											
	481	96	26.8	60.6	3.7	1.6	6.58											
	563	113	22.9	51.7	3.7	1.6	5.62											
	654	131	19.7	44.6	3.7	1.6	4.84											
	734	147	17.6	39.7	5.1	2.3	4.31											
	879	176	14.7	33.1	5.1	2.3	3.60											
	956	191	13.5	30.5	5.1	2.3	3.31											
	2.20	66	10.1	288	671	2.3	1.0						55.78	SK 33 - R150 U - 100L/4	69	5.00	6.50	88 - 89
		75	11.6	251	700	2.8	1.0						48.50					
		86	13.2	221	695	3.2	1.0						42.68					
96		14.8	196	618	3.3	1.1	37.93											
108		17	175	553	3.3	1.1	33.95											
120		18	158	498	3.3	1.1	30.56											
145		22	130	411	3.3	1.1	25.22											
173		27	109	345	3.3	1.1	21.15											
204		31	92.7	292	5.4	1.7	17.94											
222		34	85.2	269	3.3	1.1	16.49											
266		41	71.0	224	6.9	2.2	13.73											
300		46	63.1	199	7.7	2.4	12.20											
		57	8.8	330	400	1.2	1.0	63.86	SK 30 - R150 U - 100L/4	61	5.00	6.50	88 - 89					
		64	9.8	295	400	1.4	1.0	57.17										
		71	10.9	266	335	1.3	1.0	51.50										
		77	11.8	246	400	1.6	1.0	47.68										
	86	13.2	221	400	1.8	1.0	42.68											
	95	14.6	199	335	1.7	1.0	38.45											
	105	16	180	400	2.2	1.0	34.91											
	115	18	165	396	2.4	1.0	31.84											
	125	19	151	400	2.6	1.0	29.22											
	136	21	139	400	2.9	1.0	26.92											
	147	23	129	368	2.9	1.0	24.89											
	159	24	119	341	2.9	1.0	23.08											
	172	26	110	347	3.5	1.1	21.28											
	194	30	97.4	307	4.0	1.3	18.85											
	217	33	87.2	275	4.5	1.4	16.87											
	265	41	71.3	225	5.3	1.7	13.80											
	317	49	59.7	188	6.2	2.0	11.55											
	344	53	55.0	173	6.7	2.1	10.64											



**STIRNRAD-VERSTELLGETRIEBEMOTOREN
VARIABLE SPEED HELICAL GEARED MOTORS
MOTORVARIATEURS-REDUCTEURS A ENGRENAGES CYLINDRIQUES**

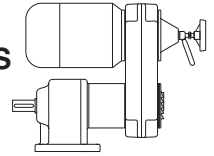

DREHSTROM
THREE PHASE
A COURANT TRIPHASE

P _n [kW]	n ₂₁ [min ⁻¹]	n ₂₂ [min ⁻¹]	M _{a1} [Nm]	M _{a2} [Nm]	f _{B1}	f _{B2}	i _{ges}	Typ Type Type	ca. kg	(400V)	i _{regel}	Maße Dimens. Cotes						
										I _N [A]								
2.20	77	11.9	244	300	1.2	1.0	47.26	SK 25 - R150 U - 100L/4	59	5.00	6.50	88 - 89						
	88	13.5	215	300	1.4	1.0	41.65											
	99	15.0	192	300	1.6	1.0	37.06											
	110	17	172	293	1.7	1.0	33.32											
	120	18	158	300	1.9	1.0	30.53											
	135	21	140	300	2.1	1.0	27.16											
	150	23	126	300	2.4	1.0	24.42											
	166	26	114	300	2.6	1.0	22.05											
	183	28	103	300	2.9	1.0	20.00											
	200	31	94.4	274	2.9	1.0	18.27											
	208	32	91.0	287	2.8	0.9	17.61											
	238	37	79.3	250	3.8	1.2	15.35											
	304	47	62.2	196	4.8	1.5	12.03											
	374	58	50.5	159	5.9	1.9	9.77											
	452	70	41.8	132	6.4	2.0	8.09											
	536	83	35.2	111	6.4	2.0	6.82											
	629	97	30.1	94.8	6.4	2.0	5.82											
	732	113	25.8	81.4	6.4	2.0	5.00											
	845	130	22.4	70.5	6.4	2.0	4.33											
	976	150	19.4	61.1	6.3	2.0	3.75											
1051	162	18.0	56.7	8.6	2.7	3.48												
	99	15.0	190	200	1.1	1.0	36.80	SK 20 V - R150 U - 100L/4	57	5.00	6.50	88 - 89						
	112	17	169	200	1.2	1.0	32.72											
	118	18	160	200	1.2	1.0	30.90											
	125	19	152	200	1.3	1.0	29.33											
	134	21	141	200	1.4	1.0	27.23											
	138	21	137	200	1.5	1.0	26.46											
	151	23	125	200	1.6	1.0	24.21											
	173	27	109	200	1.7	0.9	21.12											
	199	31	94.9	200	1.9	0.9	18.37											
	226	35	83.7	200	2.2	0.9	16.19											
	283	44	66.8	200	2.7	0.9	12.92											
	346	53	54.6	164	3.0	1.0	10.56											
	416	64	45.5	143	3.0	1.0	8.80											
	492	76	38.4	121	3.0	1.0	7.43											
	556	86	34.0	107	3.9	1.2	6.58											
	631	97	30.0	94.5	4.4	1.4	5.80											
	792	122	23.9	75.3	4.6	1.5	4.62											
	968	149	19.5	61.6	4.6	1.5	3.78											
	1064	164	17.8	56.0	4.6	1.5	3.44											
	3.00	64	9.9	400	671	1.7	1.0						55.78	SK 33 - R150 U - 100L/40	71	6.50	6.50	88 - 89
74		11.4	348	700	2.0	1.0	48.50											
84		13.0	306	700	2.3	1.0	42.68											
95		14.6	272	629	2.4	1.0	37.93											
106		16	244	563	2.4	1.0	33.95											
118		18	219	507	2.4	1.0	30.56											
143		22	181	418	2.4	1.0	25.22											
170		26	152	351	2.4	1.0	21.15											
200		31	129	297	3.9	1.7	17.94											
218		34	118	273	2.4	1.0	16.49											
262		40	98.5	228	5.0	2.1	13.73											
		75	11.6	342	400	1.2	1.0	47.68	SK 30 - R150 U - 100L/40	63	6.50	6.50	88 - 89					
		84	13.0	306	400	1.3	1.0	42.68										
	93	14.4	276	335	1.2	1.0	38.45											
	103	16	250	400	1.6	1.0	34.91											
	113	17	228	396	1.7	1.0	31.84											
	123	19	210	400	1.9	1.0	29.22											
	134	21	193	400	2.1	1.0	26.92											
	144	22	179	368	2.1	1.0	24.89											
	156	24	166	341	2.1	1.0	23.08											
	169	26	153	353	2.5	1.1	21.28											
	191	29	135	312	2.9	1.3	18.85											
	213	33	121	280	3.2	1.4	16.87											
	260	40	99.0	229	3.8	1.7	13.80											
	311	48	82.8	191	4.5	1.9	11.55											
	338	52	76.3	176	4.8	2.1	10.64											

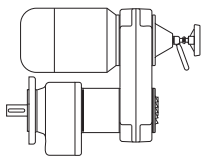

STIRNRAD-VERSTELLGETRIEBEMOTOREN
VARIABLE SPEED HELICAL GEARED MOTORS
MOTORVARIATEURS-REDUCTEURS A ENGRENAGES CYLINDRIQUES



DREHSTROM
 THREE PHASE
 A COURANT TRIPHASE

P _n [kW]	n ₂₁ [min ⁻¹]	n ₂₂ [min ⁻¹]	M _{a1} [Nm]	M _{a2} [Nm]	f _{B1}	f _{B2}	i _{ges}	Typ Type Type	ca. kg	(400V)	i _{regel}	Maße Dimens. Cotes						
										I _N [A]								
3.00	97	14.9	266	300	1.1	1.0	37.06	SK 25 - R150 U - 100L/40	61	6.50	6.50	88 - 89						
	108	17	239	293	1.2	1.0	33.32											
	118	18	219	300	1.4	1.0	30.53											
	132	20	195	300	1.5	1.0	27.16											
	147	23	175	300	1.7	1.0	24.42											
	163	25	158	300	1.9	1.0	22.05											
	180	28	143	300	2.1	1.0	20.00											
	204	31	126	292	2.0	0.9	17.61											
	234	36	110	254	2.7	1.2	15.35											
	299	46	86.3	199	3.5	1.5	12.03											
	368	57	70.1	162	4.3	1.9	9.77											
	444	68	58.0	134	4.6	2.0	8.09											
	527	81	48.9	113	4.6	2.0	6.82											
	618	95	41.7	96.5	4.6	2.0	5.82											
	719	111	35.9	82.9	4.6	2.0	5.00											
	830	128	31.1	71.8	4.6	2.0	4.33											
	959	147	26.9	62.2	4.6	2.0	3.75											
1033	159	25.0	57.7	6.2	2.7	3.48												
	136	21	190	200	1.1	1.0	26.46	SK 20 V - R150 U - 100L/40	59	6.50	6.50	88 - 89						
	148	23	174	200	1.1	1.0	24.21											
	165	25	156	200	1.3	1.0	21.73											
	183	28	141	200	1.4	1.0	19.60											
	222	34	116	200	1.6	0.9	16.19											
	278	43	92.7	200	2.0	0.9	12.92											
	340	52	75.7	164	2.2	1.0	10.56											
	409	63	63.1	146	2.2	0.9	8.80											
	484	74	53.3	123	2.2	0.9	7.43											
	546	84	47.2	109	2.8	1.2	6.58											
	620	95	41.6	96.1	3.2	1.4	5.80											
	778	120	33.1	76.6	3.3	1.4	4.62											
	951	146	27.1	62.7	3.3	1.4	3.78											
	1045	161	24.7	57.0	3.3	1.4	3.44											
	4.00	73	9.2	469	671	1.4	1.0						55.78	SK 33 - R196 U - 112M/4	82	9.00	8.00	88 - 89
		84	10.5	408	700	1.7	1.0						48.50					
		96	12.0	359	700	1.9	1.0						42.68					
108		13.5	319	651	2.0	1.0	37.93											
120		15.0	286	582	2.0	1.0	33.95											
134		17	257	524	2.0	1.0	30.56											
147		18	233	476	2.0	1.0	27.74											
162		20	212	433	2.0	1.0	25.22											
177		22	194	396	2.0	1.0	23.09											
193		24	178	363	2.0	1.0	21.15											
211		26	163	333	2.0	1.0	19.40											
228		28	151	443	3.3	1.1	17.94											
248		31	139	283	2.0	1.0	16.49											
298		37	115	339	4.2	1.4	13.73											
374		47	91.9	269	5.3	1.8	10.92											
471		59	72.9	214	5.8	2.0	8.67											
531		66	64.8	190	6.5	2.2	7.70											
	108	13.6	317	400	1.3	1.0	37.68	SK 30 V - R196 U - 112M/4	77	9.00	8.00	88 - 89						
	119	14.9	289	396	1.4	1.0	34.39											
	130	16	265	400	1.5	1.0	31.54											
	141	18	244	400	1.6	1.0	29.05											
	152	19	226	400	1.8	1.0	26.89											
	164	21	209	390	1.9	1.0	24.90											
	176	22	195	363	1.9	1.0	23.16											
	192	24	179	400	2.1	1.0	21.28											
	217	27	159	400	2.5	1.0	18.85											
	242	30	142	400	2.7	1.0	16.87											
	296	37	116	341	3.3	1.1	13.80											
	354	44	97.2	285	3.8	1.3	11.55											
	415	52	82.9	243	4.3	1.5	9.85											
	482	60	71.3	209	4.3	1.5	8.48											
	582	73	59.1	173	4.9	1.7	7.02											
	723	90	47.5	139	6.0	2.0	5.65											
	873	109	39.4	115	6.3	2.1	4.68											
1032	129	33.3	97.7	6.2	2.1	3.96												



**STIRNRAD-VERSTELLGETRIEBEMOTOREN
VARIABLE SPEED HELICAL GEARED MOTORS
MOTORVARIATEURS-REDUCTEURS A ENGRENAGES CYLINDRIQUES**

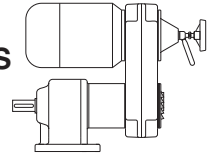

DREHSTROM
THREE PHASE
A COURANT TRIPHASE

P _n [kW]	n ₂₁ [min ⁻¹]	n ₂₂ [min ⁻¹]	M _{a1} [Nm]	M _{a2} [Nm]	f _{B1}	f _{B2}	i _{ges}	Typ Type Type	ca. kg	(400V)	i _{regel}	Maße Dimens. Cotes						
										I _N [A]								
5.50	82	10.9	577	700	1.2	1.0	48.50	SK 33 - R210 U - 132S/4	97	11.50	7.50	88 - 89						
	93	12.4	508	700	1.4	1.0	42.68											
	105	14.0	452	651	1.4	1.0	37.93											
	117	16	404	582	1.4	1.0	33.95											
	130	17	364	524	1.4	1.0	30.56											
	143	19	330	476	1.4	1.0	27.74											
	157	21	300	433	1.4	1.0	25.22											
	172	23	275	396	1.4	1.0	23.09											
	188	25	252	363	1.4	1.0	21.15											
	205	27	231	333	1.4	1.0	19.40											
	222	30	213	306	1.4	1.0	17.87											
	255	34	186	591	2.6	0.8	15.60											
	289	39	163	520	3.0	0.9	13.73											
	364	48	130	414	3.7	1.2	10.92											
	458	61	103	328	4.1	1.3	8.67											
	576	77	82.1	261	5.1	1.6	6.90											
	705	94	67.0	213	5.7	1.8	5.63											
	847	113	55.8	178	5.7	1.8	4.69											
	1008	134	46.9	149	5.7	1.8	3.94											
		126	17	375	400	1.1	1.0						31.54	SK 30 V - R210 U - 132S/4	92	11.50	7.50	88 - 89
137		18	346	400	1.2	1.0	29.05											
148		20	320	400	1.2	1.0	26.89											
159		21	296	390	1.3	1.0	24.90											
171		23	276	363	1.3	1.0	23.16											
187		25	253	400	1.5	1.0	21.28											
211		28	224	400	1.8	1.0	18.85											
235		31	201	400	1.9	1.0	16.87											
288		38	164	400	2.3	0.9	13.80											
344		46	137	400	2.7	0.9	11.55											
403		54	117	353	3.0	1.0	9.85											
468		62	101	304	3.0	1.0	8.48											
566		75	83.6	266	3.5	1.1	7.02											
703		94	67.3	214	4.2	1.3	5.65											
849		113	55.7	177	4.4	1.4	4.68											
1003		134	47.1	150	4.4	1.4	3.96											
7.50		116	15.0	556	658	1.2	1.0	34.50	SK 33 V - R210 U - 132M/4	114	15.30	7.50	88 - 89					
		132	18	489	656	1.3	1.0	30.36										
		148	20	435	583	1.3	1.0	26.98										
		166	22	389	522	1.3	1.0	24.15										
	184	25	350	470	1.3	1.0	21.74											
	203	27	318	427	1.3	1.0	19.73											
	223	30	289	675	1.7	0.7	17.94	SK 33 - R210 U - 132M/4	108	15.30	7.50	88 - 89						
	256	34	252	587	1.9	0.8	15.60											
	291	39	221	517	2.2	0.9	13.73											
	366	49	176	411	2.8	1.2	10.92											
	461	61	140	326	3.0	1.3	8.67											
	579	77	111	260	3.8	1.6	6.90											
	710	95	90.8	212	4.2	1.8	5.63											
	853	114	75.6	176	4.2	1.8	4.69											
	1015	135	63.5	148	4.2	1.8	3.94											
		188	25	343	400	1.1	1.0						21.28	SK 30 V - R210 U - 132M/4	103	15.30	7.50	88 - 89
212		28	304	400	1.3	1.0	18.85											
237		32	272	400	1.4	1.0	16.87											
290		39	222	400	1.7	0.9	13.80											
346		46	186	400	2.0	0.9	11.55											
406		54	159	353	2.2	1.0	9.85											
472		63	137	304	2.2	1.0	8.48											
570		76	113	264	2.6	1.1	7.02											
708		94	91.1	213	3.1	1.3	5.65											
854		114	75.5	176	3.3	1.4	4.68											
1010		135	63.8	149	3.3	1.4	3.96											

STIRNRAD - VERSTELLGETRIEBEMOTOREN VARIABLE SPEED HELICAL GEARED MOTORS MOTOVARIATEURS - REDUCTEURS A ENGRENAGES CYLINDRIQUES



U - AUSFÜHRUNG, ZWEISTUFIG
U - DESIGN, DOUBLE REDUCTION
EXECUTION U, A DEUX TRAINS D'ENGRENAGES

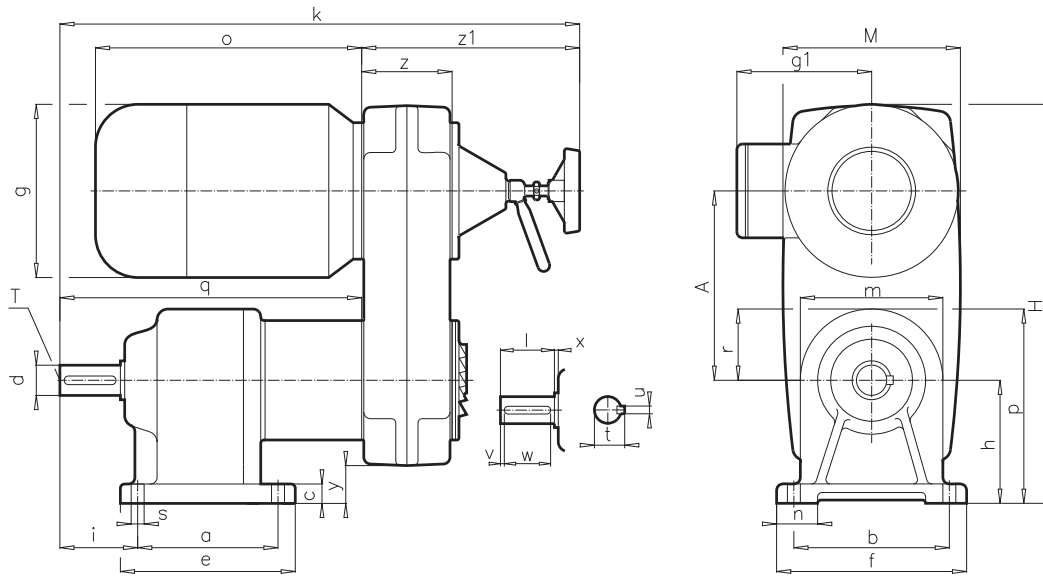

Typ Type Type	Befestigungsmaße Mounting dimensions Cotes de fixation				Raum- und Anschlußmaße Outline dimensions Cotes d'encombrement												Motor Motor Moteur			Wellenmaße Shaft dimensions Cotes arbre			
	a	c	f	s	h i m q k r y z z1 A H M												g	g1	o	d	t	v	x
	b	e	n		h	i	p	q	k	r	y	z	z1	A	H	M	g	g1	o	l	u	w	T
SK 0 - R 080 U - 71 S/L	50	12	130	8,5	86	52	110	216	354	50	28	54	138	150	294	120	145	116	216	16	18,0	4	2
	110	78	20				136													40	5	32	M 5
SK 01 - R 080 U - 71 S/L	85	15	135	8,5	102	68	135	227	365	67,5	44	54	138	150	310	152	145	119	216	20	22,5	5	2
							170																
- R 100 U - 80 S/L	105	110	30		102	68	135	208	445	67,5	30	88	237	170	344	120	165	140	231	40	6	30	M 6
- R 90 S/L							170										185	145	276				
SK 20 - R 100 U - 80 S/L	80	18	185	11	125	74	150	246	483	75	53	88	237	170	367	120	165	140	231	25	28,0	10	2
							200										185	145	276				
- R 90 S/L							200																
- R 150 U - 100 L	160	110	30		125	74	150	258	523	75	25	106	265	222	447	208	203	154	306	60	8	40	M10
							200																
SK 25 - R 100 U - 80 S/L	140	20	190	13	130	115	170	284	521	85	58	88	237	170	372	120	165	140	231	30	33,0	10	2
							215																
- R 150 U - 100 L	155	175	35		130	115	170	284	549	85	30	106	265	222	452	208	203	154	306	70	8	50	M10
							215																
SK 30 - R 100 U - 80 S/L	90	20	210	13	155	86	170	282	519	85	83	88	237	170	397	120	165	140	231	35	38,0	10	3
							240																
- R 150 U - 100 L	185	125	35		155	86	170	282	547	85	55	106	265	222	477	208	203	154	306	70	10	50	M12
							240																
- R 196 U - 112 M					155	86	170	337	657	85	35	128	320	258	533	250	228	166	326				
							240																
- R 210 U - 132 S/M					155	86	170	337	673	85	25	140	336	262	547	270	266	194	411				
							240																
SK 33 - R 150 U - 100 L	134	25	215	13	175	120	200	362	627	100	75	106	265	222	497	208	203	154	306	40	43,0	10	3
							275																
- R 196 U - 112 M	175	165	40		175	120	200	362	682	100	55	128	320	258	553	250	228	166	326	80	12	60	M16
							275																
- R 210 U - 132 S/M					175	120	200	362	698	100	45	140	336	262	567	270	266	194	411				
							275																

Die Stirnrad - Verstelltriebemotoren sind mit verstärkten Abtriebswellen lieferbar, siehe Seite 4.

The variable Speed Helical Geared Motors can be supplied with reinforced output shafts, see page 4.

Les motovariateurs-réducteurs à engrenages cylindriques peuvent être livrés avec des arbres de sortie, voir page 4.

STIRNRAD - VERSTELLGETRIEBEMOTOREN VARIABLE SPEED HELICAL GEARED MOTORS MOTOVARIATEURS - REDUCTEURS A ENGRENAGES CYLINDRIQUES



U - AUSFÜHRUNG, ZWEISTUFIG
U - DESIGN, DOUBLE REDUCTION
EXECUTION U, A DEUX TRAINS D'ENGRENAGES

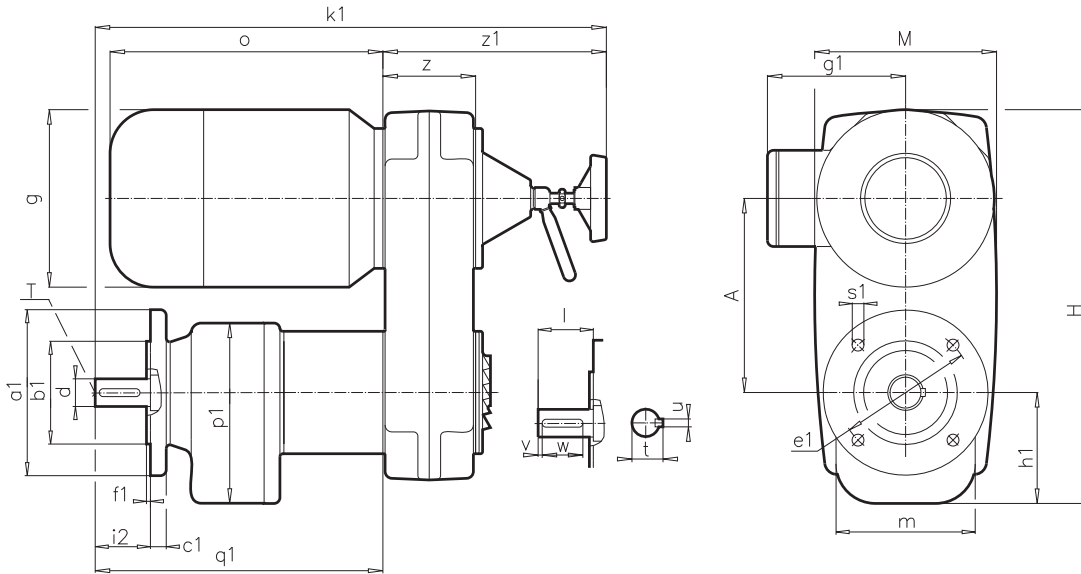

Typ Type Type	Befestigungsmaße Mounting dimensions Cotes de fixation						Raum- und Anschlußmaße Outline dimensions Cotes d'encombrement								Motor Motor Moteur			Wellenmaße Shaft dimensions Cotes arbre					
	a1	b1	c1	e1	f1	s1	h1	i2	m	p1	q1	k1	z	z1	A	H	M	g	g1	o	d	t	v
SK 0 F - R 080 U - 71 S/L	105	70	10	85	3,0	M6	85	40	100	216	354	54	138	150	293	120	145	119	216	16	18,0	4	M 5
	120	80	10	100	3,0	7														40	5	32	
	140	95	10	115	3,0	9			135														
SK 01 F - R 080 U - 71 S/L	120	80	10	100	3,0	7	98	40	135	227	365	54	138	150	306	152	145	119	216	20	22,5	5	M 6
	140	95	10	115	3,0	9			166											40	6	30	
	120	80	10	100	3,0	7	98	40	135	208	445	88	237	170	340	120	165	140	231				
- R 100 U - 80 S/L	140	95	10	115	3,0	9			166														
	160	110	10	130	3,5	9																	
	120	80	10	100	3,0	7	98	40	135	208	445	88	237	170	340	120	185	145	276				
- R 100 U - 90 S/L	140	95	10	115	3,0	9			166														
	120	80	10	100	3,0	7	98	40	135	208	445	88	237	170	340	120	185	145	276				
	140	95	10	115	3,0	9			166														
SK 20 F - R 100 U - 80 S/L	140	95	10	100	3,0	9	123	60	150	246	483	88	237	170	365	120	165	140	231	25	28,0	10	M10
	160	110	10	130	3,5	9			198											60	8	40	
	140	95	10	100	3,0	9	123	60	150	246	483	88	237	170	365	120	185	145	276				
- R 100 U - 90 S/L	160	110	10	130	3,5	9			198														
	200	130	12	165	3,5	11																	
	140	95	10	115	3,0	9	123	60	150	258	523	106	265	222	445	208	203	154	306				
SK 25 F - R 100 U - 80 S/L	160	110	12	130	3,5	9	128	70	170	284	521	88	237	170	370	120	165	140	231	30	33,0	10	M10
									213											70	8	50	
	160	110	12	130	3,5	9	128	70	170	284	549	106	265	222	450	208	203	154	306				
- R 150 U - 100 L	200	130	12	165	3,5	11			213														
	160	110	12	130	3,5	9	153	70	170	282	519	88	237	170	395	120	165	140	231	35	38,0	10	M12
	200	130	12	165	3,5	11			238											70	10	50	
SK 30 F - R 100 U - 80 S/L	160	110	12	130	3,5	9	153	70	170	282	519	88	237	170	395	120	165	140	231				
	200	130	12	165	3,5	11			238											70	10	50	
	160	110	12	130	3,5	9	153	70	170	337	657	128	320	258	531	250	228	166	326				
- R 196 U - 112 M	200	130	12	165	3,5	11			238														
	250	180	12	215	4,0	14																	
	160	110	12	130	3,5	9	153	70	170	337	673	140	336	262	545	270	266	194	411				
- R 210 U - 132 S/M	200	130	12	165	3,5	11			238														
	250	180	12	215	4,0	14																	
	200	130	14	165	3,5	11	173	80	200	362	627	106	265	222	495	208	203	154	306	40	43,0	10	M16
SK 33 F - R 150 U - 100 L	250	180	16	215	4,0	14			273														
	200	130	14	165	3,5	11	173	80	200	362	682	128	320	258	551	250	228	166	326				
	200	130	14	165	3,5	11	173	80	200	362	698	140	336	262	565	270	266	194	411	80	12	60	
- R 210 U - 132 S/M	250	180	16	215	4,0	14			273														

* Fettgedruckte Flanschmaße beziehen sich auf die Normalausführung.
Die anderen Flansche können alternativ gegen Mehrpreis geliefert werden.

Die Stirnrad - Verstellgetriebemotoren sind mit verstärkten Abtriebswellen lieferbar, siehe Seite 4.

Technische Änderungen vorbehalten

* Bold typed dimensions refer to standard design.
All other flanges can be supplied optionally with surcharges.

The variable Speed Helical Geared Motors can be supplied with reinforced output shafts, see page 4.

Technical design may be subject to change.

* Cotes imprimées en caractères gras se réfèrent à l'exécution normale.
Les autres brides peuvent être livrées sur commandes avec supplément.

Les motovariateurs-réducteurs à engrenages cylindriques peuvent être livrés avec des arbres de sortie, voir page 4.

Sous réserve de modifications techniques.

STIRNRAD - VERSTELLGETRIEBEMOTOREN VARIABLE SPEED HELICAL GEARED MOTORS MOTOVARIATEURS - REDUCTEURS A ENGRENAGES CYLINDRIQUES



Z - AUSFÜHRUNG, ZWEISTUFIG
Z - DESIGN, DOUBLE REDUCTION
EXECUTION Z, A DEUX TRAINS D'ENGRENAGES

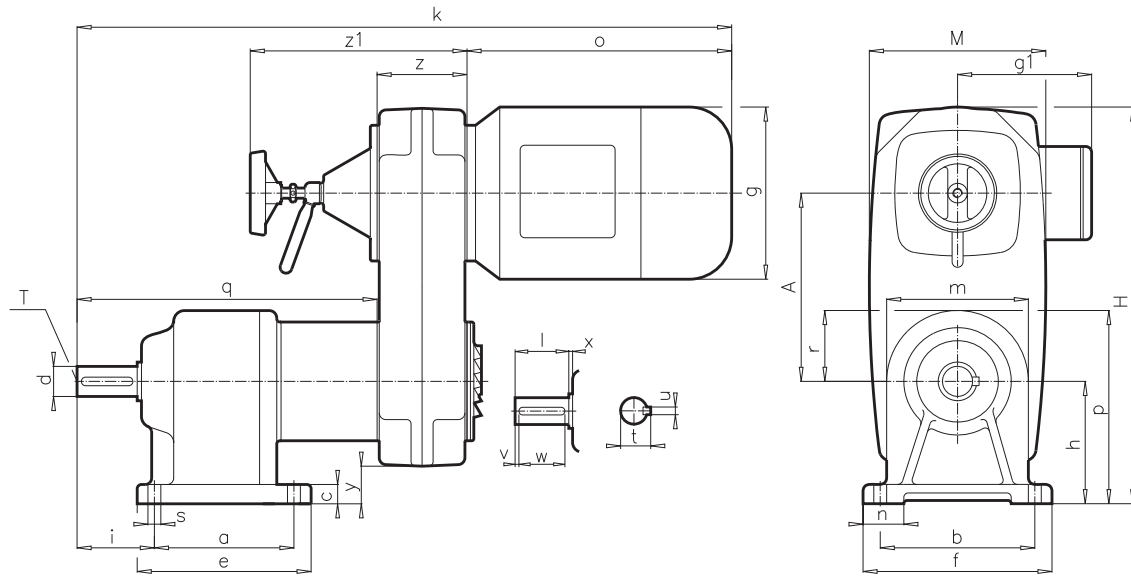

Typ Type Type	Befestigungsmaße Mounting dimensions Cotes de fixation				Raum- und Anschlußmaße Outline dimensions Cotes d'encombrement												Motor Motor Moteur			Wellenmaße Shaft dimensions Cotes arbre			
	a	c	f	s	h	i	m	q	k	r	y	z	z1	A	H	M	g	g1	o	d	t	v	x
	b	e	n				p													l	u	w	T
SK 0 - R 080 Z - 71 S/L	50	12	130	8,5	86	52	110	216	486	50	28	54	138	150	294	120	145	119	216	16	18,0	4	2
	110	78	20				136													40	5	32	M 5
SK 01 - R 080 Z - 71 S/L	85	15	135	8,5	102	68	135	227	497	67,5	44	54	138	150	310	152	145	119	216	20	22,5	5	2
							170																
SK 01 - R 100 Z - 80 S/L - R 90 S/L	105	110	30		102	68	135	208	527	67,5	30	88	237	170	344	120	165	140	231	40	6	30	M 6
							170		572								185	145	276				
SK 20 - R 100 Z - 80 S/L - R 90 S/L	80	18	185	11	125	74	150	246	565	75	53	88	237	170	367	120	165	140	231	25	28,0	10	2
							200		610								185	145	276				
SK 20 - R 150 Z - 100 L	160	110	30		125	74	150	258	670	75	25	106	265	222	447	208	203	154	306	60	8	40	M10
							200																
SK 25 - R 100 Z - 80 S/L - R 90 S/L	140	20	190	13	130	115	170	284	603	85	58	88	237	170	372	120	165	140	231	30	33,0	10	2
							215		648								185	145	276				
SK 25 - R 150 Z - 100 L	155	175	35		130	115	170	284	696	85	30	106	265	222	452	208	203	154	306	70	8	50	M10
							215																
SK 30 - R 100 Z - 80 S/L - R 90 S/L - R 196 Z - 112 M - R 210 Z - 132 S/M	90	20	210	13	155	86	170	282	601	85	83	88	237	170	397	120	165	140	231	35	38,0	10	3
							240		646								185	145	276				
	185	125	35		155	86	170	282	694	85	55	106	265	222	477	208	203	154	306	70	10	50	M12
							240																
SK 33 - R 150 Z - 100 L - R 196 Z - 112 M - R 210 Z - 132 S/M	134	25	215	13	175	120	200	362	774	100	75	106	265	222	497	208	203	154	306	40	43,0	10	3
							275																
	175	165	40		175	120	200	362	816	100	55	128	320	258	553	250	228	166	326	80	12	60	M16
						275																	
				175	120	200	362	913	100	45	140	336	262	567	270	266	194	411					
						275																	

Die Stirnrad - Verstellgetriebemotoren sind mit verstärkten Abtriebswellen lieferbar, siehe Seite 4.

The variable Speed Helical Geared Motors can be supplied with reinforced output shafts, see page 4.

Les motovariateurs-réducteurs à engrenages cylindriques peuvent être livrés avec des arbres de sortie, voir page 4.

STIRNRAD - VERSTELLGETRIEBEMOTOREN VARIABLE SPEED HELICAL GEARED MOTORS MOTOVARIATEURS - REDUCTEURS A ENGRENAGES CYLINDRIQUES



Z - AUSFÜHRUNG, ZWEISTUFIG
Z - DESIGN, DOUBLE REDUCTION
EXECUTION Z, A DEUX TRAINS D'ENGRENAGES

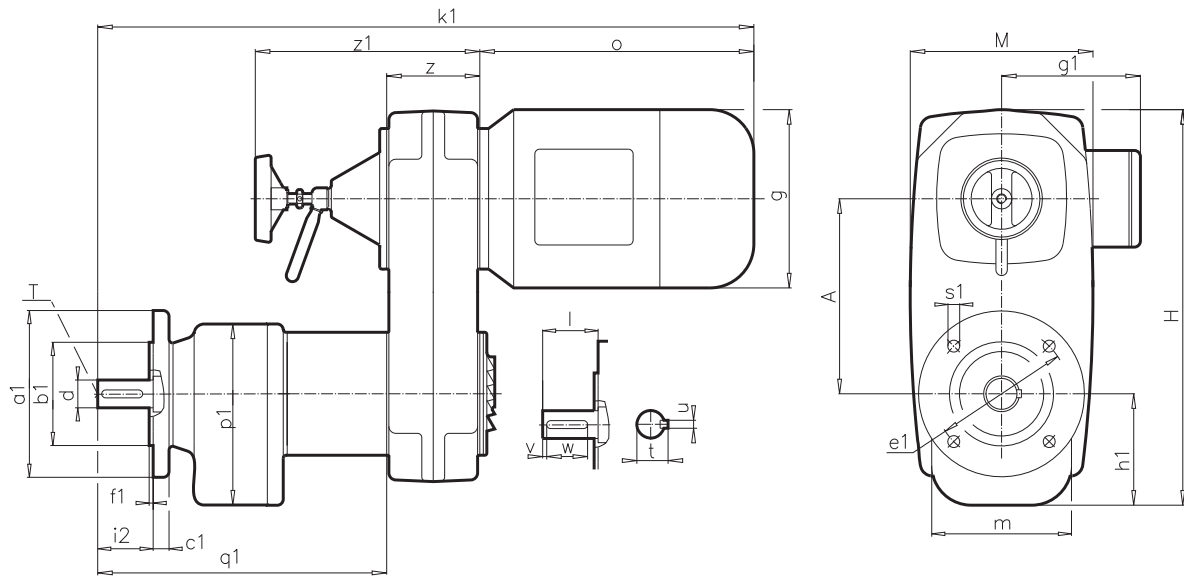

Typ Type Type	Befestigungsmaße Mounting dimensions Cotes de fixation						Raum - und Anschlußmaße Outline dimensions Cotes d'encombrement										Motor Motor Moteur			Wellenmaße Shaft dimensions Cotes arbre			
	a1	b1	c1	e1	f1	s1	h1	i2	m	q1	k1	z	z1	A	H	M	g	g1	o	d	t	v	T
									p1											l	u	w	
SK 0 F - R 080 Z - 71 S/L	105	70	10	85	3,0	M6	85	40	100	216	486	54	138	150	293	120	145	119	216	16	18,0	4	M 5
	120	80	10	100	3,0	7														40	5	32	
	140	95	10	115	3,0	9			135														
	160	110	10	130	3,5	9																	
SK 01 F - R 080 Z - 71 S/L - R 100 Z - 80 S/L - 90 S/L	120	80	10	100	3,0	7	98	40	135	227	497	54	138	150	306	152	145	119	216	20	22,5	5	M 6
	140	95	10	115	3,0	9			166											40	6	30	
	160	110	10	130	3,5	9	98	40	135	208	527	88	237	170	340	120	165	140	231				
	200	130	10	165	3,5	11			166	572							185	145	276				
SK 20 F - R 100 Z - 80 S/L - 90 S/L - R 150 Z - 100 L	140	95	10	100	3,0	9	123	60	150	246	565	88	237	170	365	120	165	140	231	25	28,0	10	M10
	160	110	10	130	3,5	9			198	610							185	145	276				
	200	130	12	165	3,5	11	123	60	150	258	670	106	265	222	445	208	203	154	306	60	8	40	
	250	180	12	215	4,0	14			198														
SK 25 F - R 100 Z - 80 S/L - 90 S/L - R 150 Z - 100 L	160	110	12	130	3,5	9	128	70	170	284	603	88	237	170	370	120	165	140	231	30	33,0	10	M10
	200	130	12	165	3,5	11			213	648							185	145	276				
	250	180	12	215	4,0	14	128	70	170	284	696	106	265	222	450	208	203	154	306	70	8	50	
	300	230	12	265	4,0	14			213														
SK 30 F - R 100 Z - 80 S/L - 90 S/L - R 150 Z - 100 L - R 196 Z - 112 M - R 210 Z - 132 S/M	160	110	12	130	3,5	9	153	70	170	282	601	88	237	170	395	120	165	140	231	35	38,0	10	M12
	200	130	12	165	3,5	11			238	646							185	145	276				
	250	180	12	215	4,0	14	153	70	170	282	694	106	265	222	475	208	203	154	306	70	10	50	
	300	230	12	265	4,0	14			238														
SK 33 F - R 150 Z - 100 L - R 196 Z - 112 M - R 210 Z - 132 S/M	200	130	14	165	3,5	11	173	80	200	362	774	106	265	222	495	208	203	154	306	40	43,0	10	M16
	250	180	16	215	4,0	14			273														
	300	230	16	265	4,0	14	173	80	200	362	816	128	320	258	551	250	228	166	326	80	12	60	
									273														
						173	80	200	362	913	140	336	262	565	270	228	166	326					
								273								266	194	411					

* Fettgedruckte Flanschmaße beziehen sich auf die Normalausführung.
Die anderen Flansche können alternativ gegen Mehrpreis geliefert werden.

Die Stirnrad - Verstellgetriebemotoren sind mit verstärkten Abtriebswellen lieferbar, siehe Seite 4.

Technische Änderungen vorbehalten

* Heavy-face typed dimensions refer to standard design.
All other flanges can be supplied optionally with surcharges.

The variable Speed Helical Geared Motors can be supplied with reinforced output shafts, see page 4.

Technical design may be subject to change.

* Cotes imprimées en caractères gras se réfèrent à l'exécution normale.
Les autres brides peuvent être livrées sur commandes avec supplément.

Les motovariateurs-réducteurs à engrenages cylindriques peuvent être livrés avec des arbres de sortie, voir page 4.

Sous réserve de modifications techniques.

**ALLGEMEINE ERSATZTEILE
GENERAL PARTS LIST
VUE ECLATEE ET NOMENCLATURE**



**STIRNRADGETRIEBEMOTOR
ZWEISTUFIG**

**HELICAL GEARED MOTOR
DOUBLE REDUCTION**

**MOTOREDUCTEURS A ENGRENAGES
CYLINDRIQUES
A DEUX TRAINS D'ENGRENAGES**

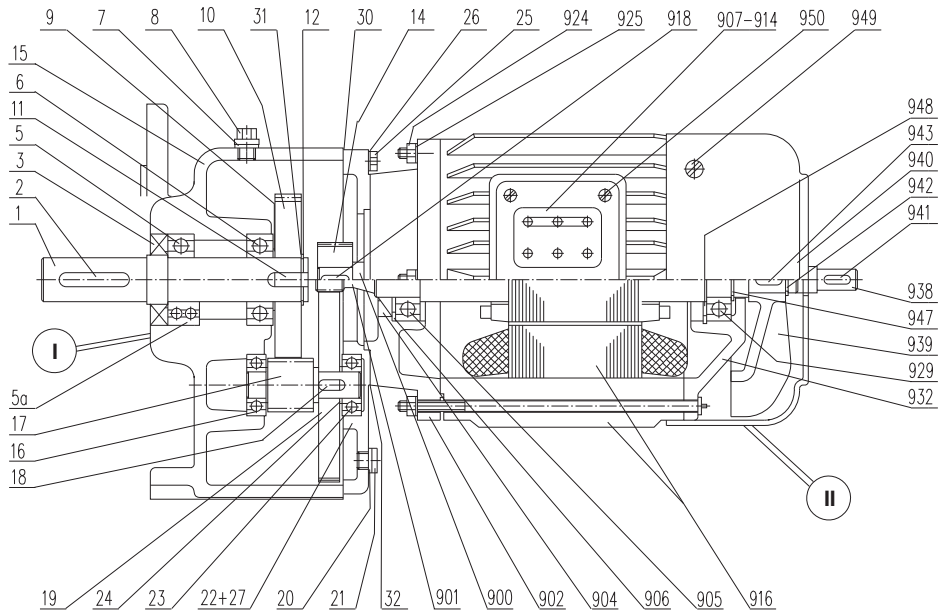

**STIRNRADGETRIEBEMOTOR
DREISTUFIG**

**HELICAL GEARED MOTOR
TRIPLE REDUCTION**

**MOTOREDUCTEURS A ENGRENAGES
CYLINDRIQUES
A TROIS TRAINS D'ENGRENAGES**

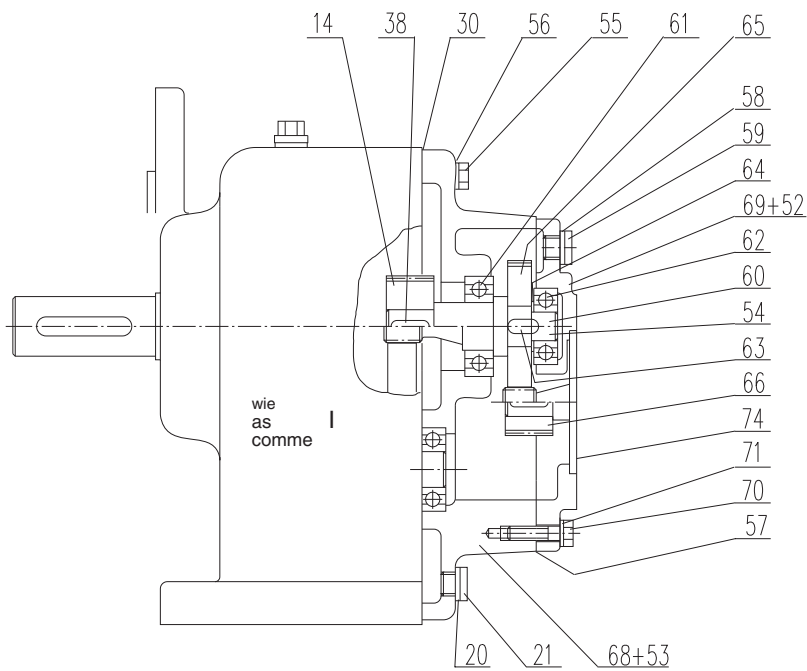



ALLGEMEINE ERSATZTEILE GENERAL PARTS LIST VUE ECLATEE ET NOMENCLATURE

1	Abtriebswelle	1	Output shaft	1	Arbre de sortie
2	Paßfeder	2	Key	2	Clavette
3	Wellendichtring	3	Shaft seal	3	Bague d'étanchéité
5	Abtriebswellenlager, normal	5	Output shaft bearing, normal	5	Roulement de l'arbre de sortie, normal
5a	Abtriebswellenlager, verstärkt	5a	Output shaft bearing, reinforced	5a	Roulement de l'arbre de sortie, renforcé
6	Abtriebswellenlager	6	Output shaft bearing	6	Roulement de l'arbre de sortie
7	IT-Öldichtung	7	Seal	7	Joint
8	Entlüftungsschraube	8	Vent screw	8	Vis d'évent
9	Paßscheibe	9	Shim	9	Rondelle d'ajustage
10	Abtriebsrad	10	Driven gear	10	Roue de sortie
11	Paßfeder	11	Key	11	Clavette
12	Sicherungsring	12	Circlip	12	Circlips
14	Antriebsritzel	14	Driving pinion	14	Pignon d'entrée
15	Getriebegehäuse	15	Gear case	15	Carter
16	Ritzellager	16	Pinion shaft bearing	16	Roulement de l'arbre intermédiaire
17	Abtriebsritzel	17	Driven pinion	17	Pignon d'entrée
18	Paßfeder	18	Key	18	Clavette
19	Antriebsrad	19	Driving gear	19	Roue d'entrée
20	IT-Öldichtung	20	Seal	20	Joint
21	Verschußschraube	21	Plug	21	Vis de vidange
22	Getriebedeckel	22	Gear case cover	22	Couvercle du réducteur
23	Ritzellager	23	Pinion shaft bearing	23	Roulement de l'arbre intermédiaire
24	Paßscheibe	24	Shim	24	Rondelle d'ajustage
25	Sechskantschraube	25	Hexagon bolt	25	Vis hexagonale
26	Federring	26	Washer	26	Rondelle à ressort
27	Spiralspannstift	27	Spiral pin	27	Goupille fendue
30	Dichtung	30	Seal	30	Joint
31	Paßscheibe	31	Shim	31	Rondelle d'ajustage
32	Dichtung	32	Seal	32	Joint
52	Spiralspannstift	52	Spiral pin	52	Goupille fendue
53	Spiralspannstift	53	Spiral pin	53	Goupille fendue
54	Zwischenwelle, verzahnt	54	Intermediate shaft, gearcut	54	Arbre intermédiaire, taillé
55	Sechskantschraube	55	Hexagon bolt	55	Vis hexagonale
56	Federring	56	Washer	56	Rondelle à ressort
57	Dichtung	57	Seal	57	Joint
58	IT-Öldichtung	58	Seal	58	Joint
59	Verschußschraube	59	Plug	59	Vis de vidange
60	Zwischenwelle, glatt	60	Intermediate shaft, plain	60	Arbre intermédiaire, lisse
61	Rillenkugellager	61	Grooved ball bearing	61	Roulement à billes
62	Rillenkugellager	62	Grooved ball bearing	62	Roulement à billes
63	Paßfeder	63	Key	63	Clavette
64	Paßscheibe	64	Shim	64	Rondelle d'ajustage
65	Antriebsrad	65	Driving gear	65	Roue intermédiaire
66	Antriebsritzel	66	Driving pinion	66	Pignon d'entrée
68	Getriebegehäuse 3. Stufe	68	Gear case 3rd.-red.	68	Carter réd. 3 ème train d'engrenages
69	Getriebedeckel	69	Gear case cover	69	Couvercle du réducteur
70	Sechskantschraube	70	Hexagon bolt	70	Vis hexagonale
71	Federring	71	Washer	71	Rondelle à ressort
74	Dichtung	74	Seal	74	Joint
900	Rotor mit Welle, glatt	900	Rotor with shaft, plain	900	Rotor avec bout d'arbre, lisse
901	Rotor mit Welle, verzahnt	901	Rotor with shaft, gearcut	901	Rotor avec bout d'arbre, taillé
902	A-Lagerschild	902	End shield A	902	Flasque palier A
904	Wellendichtring	904	Shaft seal	904	Bague d'étanchéité
905	A-Lager	905	Bearing A	905	Roulement A
906	Kugellager-Ausgleichsscheibe	906	Bearing shim	906	Disques d'égalisation pour roulement
907	Klemmkastenrahmen	907	Terminal box frame	907	Cocle de boîte à bornes
908	Klemmkastendeckel	908	Terminal box cover	908	Couvercle de boîte à bornes
909	Klemmkasten-Rahmendichtung	909	Terminal box frame gasket	909	Joint de socle de boîte à bornes
910	Klemmkasten-Deckeldichtung	910	Terminal box cover gasket	910	Joint de couvercle de boîte à bornes
911	Klembrett	911	Terminal board	911	Plasque à bornes
914	PG-Verschraubung	914	cabl e entry gland	914	Vis de jonction
916	Statorgehäuse	916	Stator case	916	Carter de stator
918	Paßfeder	918	Key	918	Clavette
924	Bundschraube	924	Collar bolt	924	Vis epaulée
925	Sechskantmutter	925	Hexagonal nut	925	Ecrou à six pans
929	B-Lager	929	Bearing B	929	Roulement B
932	B-Lagerschild	932	End shield B	932	Flasque palier B
938	Rotorwelle mit 2. Wellenende	938	Second motor shaft end	938	Deuxième bout d'arbre moteur
939	Ventilator	939	Fan	939	Ventilateur
940	Ventilatorhaube	940	Fan cover	940	Capot ventilateur
941	Paßfeder	941	Key	941	Clavette
942	Sicherungsring	942	Circlip	942	Circlips
943	Paßfeder	943	Key	943	Clavette
947	Sicherungsring	947	Circlip	947	Circlips
948	Sicherungsring	948	Circlip	948	Circlips
949	Linsensenkschraube	949	Oval flat-head bolt	949	Vis à tête fraisée lentiforme
950	Linsensenkschraube	950	Oval flat-head bolt	950	Vis à tête fraisée lentiforme

**ALLGEMEINE ERSATZTEILE
GENERAL PARTS LIST
VUE ECLATEE ET NOMENCLATURE**



**STIRNRADGETRIEBE MIT FREIER
ANTRIEBSWELLE**

TYPENZUSATZ: W

**HELICAL GEARBOX
WITH FREE INPUT SHAFT**

AFFIX: W

**REDUCTEURS A ENGRENAGES CYLINDRIQUES
AVEC ARBRE D'ENTREE LIBRE**

SUFFIXE: W

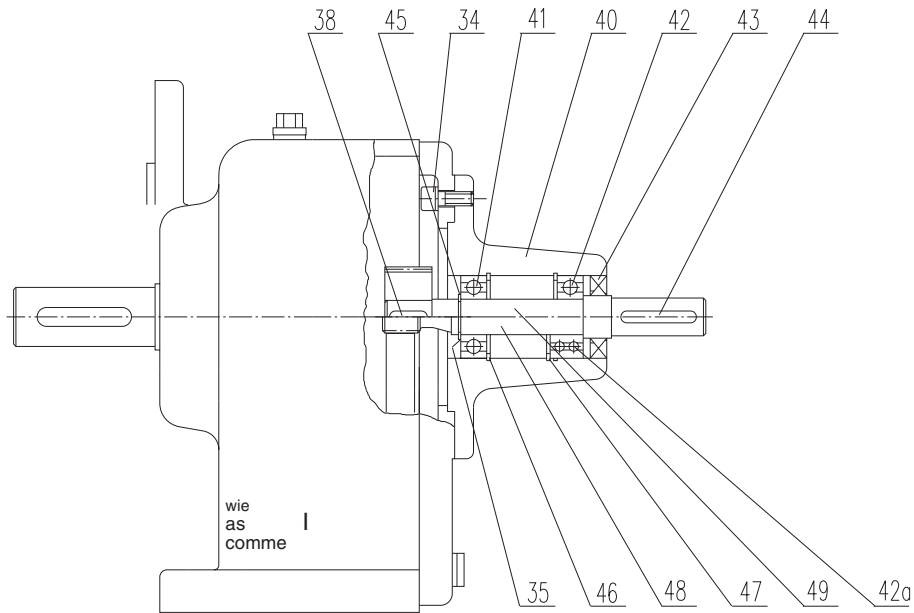

**STIRNRADGETRIEBE ZUM ANFLANSCHEN VON
IEC - NORMMOTOREN NACH DIN 42677**

TYPENZUSATZ: IEC

**HELICAL GEARBOX FOR ASSEMBLY WITH
IEC STANDARD MOTORS ACC: TO DIN 42677**

AFFIX: IEC

**REDUCTEURS A ENGRENAGES CYLINDRIQUES
POUR MONTAGE MOTEURS NORME SELON
DIN 42677**

SUFFIXE: IEC

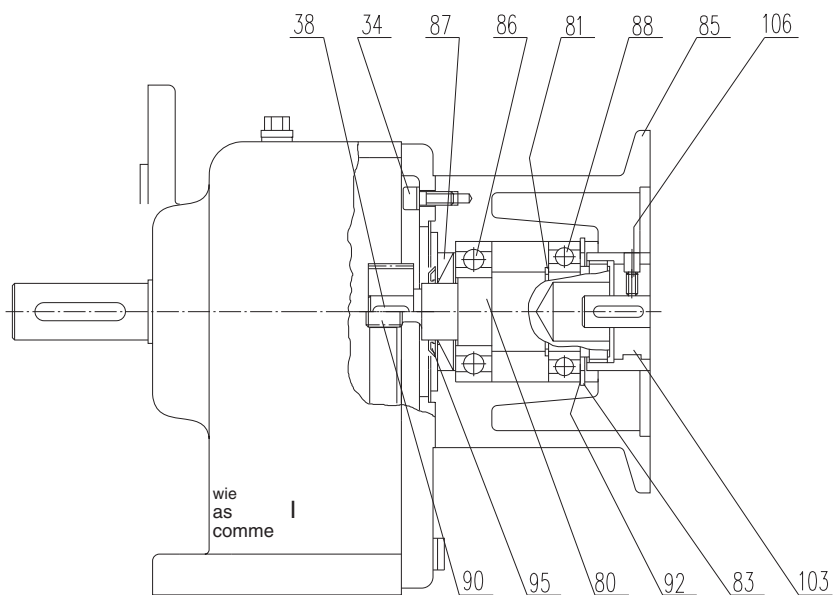



**ALLGEMEINE ERSATZTEILE
GENERAL PARTS LIST
VUE ECLATEE ET NOMENCLATURE**

34	Zylinderschraube	34	Socket head bolt	34	Vis à tête cylindrique
35	Paßscheibe	35	Shim	35	Rondelle ajustage
38	Paßfeder	38	Key	38	Clavette
40	Antriebslagergehäuse	40	Input bearing housing	40	Carter de palier d'entrée
41	Rillenkugellager	41	Grooved ball bearing	41	Roulement à billes
42	Rillenkugellager, normal	42	Grooved ball bearing, normal	42	Roulement à billes, normal
42a	Rillenkugellager, verstärkt	42a	Grooved ball bearing, reinforced	42a	Roulement à billes, renforcé
43	Wellendichtung	43	Shaft seal	43	Bague d'étanchéité
44	Paßfeder	44	Key	44	Clavette
45	Sicherungsring	45	Circlip	45	Circlips
46	Sicherungsring	46	Circlip	46	Circlips
47	Sicherungsring	47	Circlip	47	Circlips
48	Antriebswelle, verzahnt	48	Input shaft gearcut	48	Arbre d'entrée, taillé
49	Antriebswelle glatt	49	Input shaft, plain	49	Arbre d'entrée, lisse
80	Mitnehmerwelle	80	Input shaft	80	Arbre d'entraînement
81	Sicherungsring	81	Circlip	81	Circlips
83	Sicherungsring	83	Circlip	83	Circlips
85	IEC-Zylinder	85	IEC Adaptor	85	Lanterne IEC
86	Mitnehmerwellenlager	86	Input shaft bearing	86	Roulement d'arbre d'entraînement
87	Wellendichtring	87	Shaft seal	87	Bague d'étanchéité
88	Mitnehmerwellenlager	88	Input shaft gearcut	88	Roulement d'arbre d'entraînement
90	Mitnehmer-Ritzelwelle	90	Clutch pinion shaft	90	Arbre du pinion d'entraînement
92	Paßscheibe	92	Shim	92	Rondelle d'ajustage
95	Gamma-Ring	95	Oil flinger	95	Défecteur
103	Kupplung	103	Coupling	103	Accouplement
106	Gewindestift	106	Set screw	106	Vis à tête creuse

**ALLGEMEINE ERSATZTEILE
GENERAL PARTS LIST
VUE ECLATEE ET NOMENCLATURE**

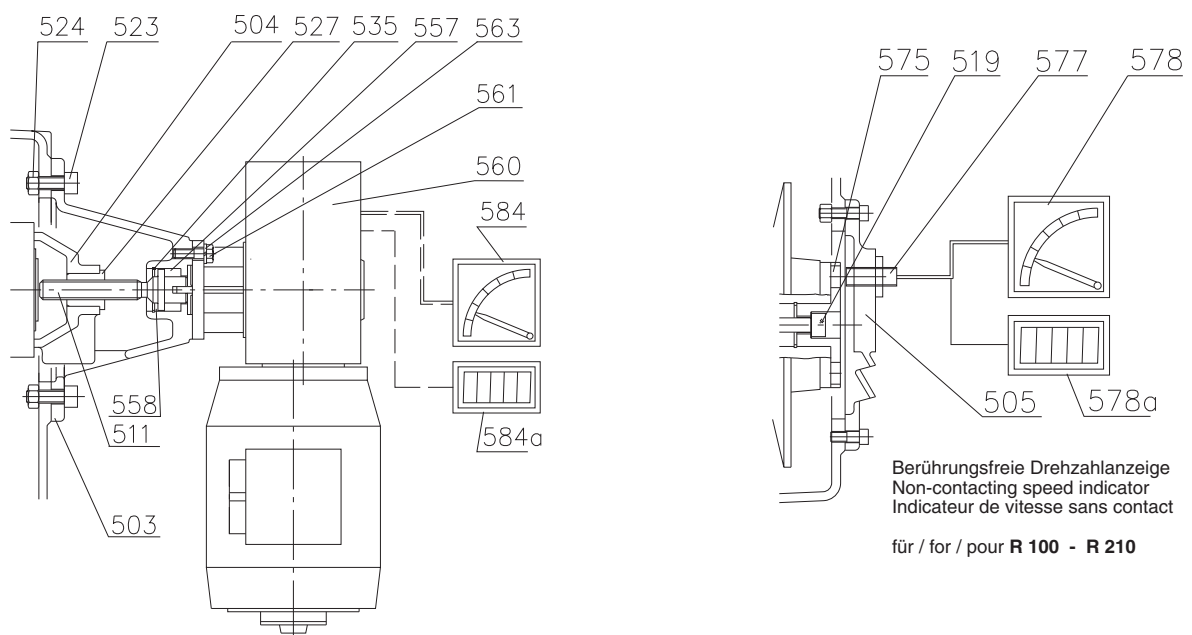
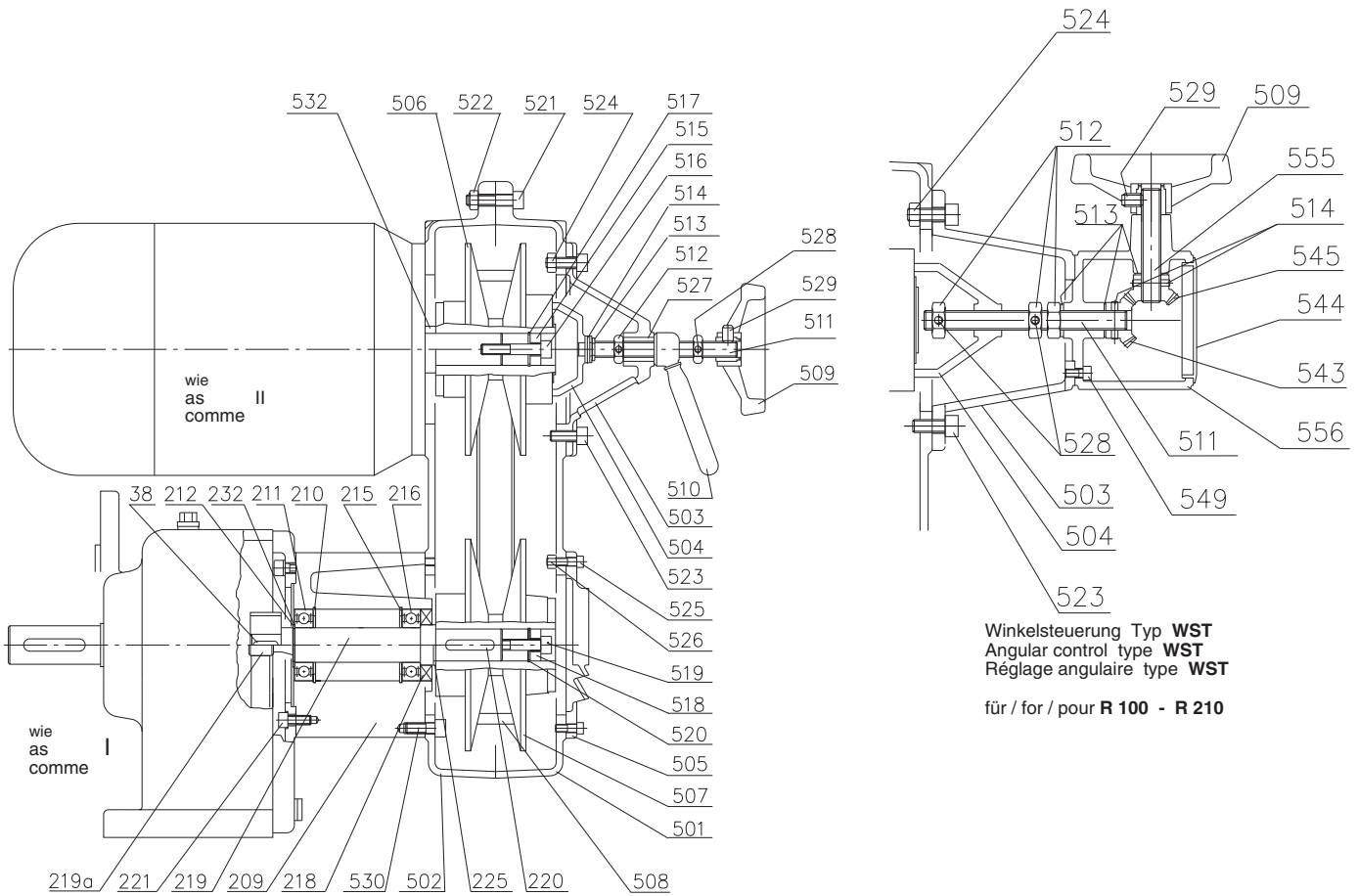

Elektrische Fernverstellung Typ **EMFST**
Electric Remote Control type **EMFST**
Téléréglage électrique type **EMFST**

für / for / pour **R 100 - R 210**

**ALLGEMEINE ERSATZTEILE
GENERAL PARTS LIST
VUE ECLATEE ET NOMENCLATURE**



38	Paßfeder	38	Key	38	Clavette
209	Anbauzylinder	209	Modular cylinder	209	Cylindre modulaire
210	Sicherungsring	210	Circlip	210	Circlips
211	Antriebslager	211	Input ball bearing	211	Roulement d'entrée
212	Sicherungsring	212	Circlip	212	Circlips
215	Sicherungsring	215	Circlip	215	Circlips
216	Antriebslager	216	Input ball bearing	216	Roulement d'entrée
218	Wellendichtring	218	Shaft seal	218	Bague d'échantéité
219	Antriebswelle, glatt	219	Input shaft, plain	219	Arbre d'entrée, lisse
219a	Antriebswelle, verzahnt	219a	Input shaft, gearcut	219a	Arbre d'entrée, taillé
220	Paßfeder	220	Key	220	Clavette
221	Zylinderschraube	221	Socket head bolt	221	Vis à tête cylindrique
222	Paßscheibe	222	Shim	222	Rondelle d'ajustage
225	Stützscheibe	225	Supporting disc	225	Rondelle de support
501	Abdeckhaube	501	Cover	501	Demi-carter
502	Verbindungsflansch	502	Connecting flange	502	Bride pour connection
503	Steuertopf	503	Adjustment cover	503	Couvercle de réglage
504	Drucktopf	504	Adjusting cone	504	Pot de réglage
505	Belüftungsdeckel	505	Ventilation cover	505	Carter der ventilation
506	Verstellscheibe	506	Adjustable pulley	506	Poulie motrice
507	Federscheibe	507	Spring loaded pulley	507	Puillie menée
508	Keilriemen	508	V-belt	508	Courroie trapézoidale
509	Handrad	509	Handwheel	509	Volant de manoeuvre
510	Kegelgriff	510	Locking handle	510	Levier de blocage
511	Gewindestindel	511	Spindle	511	Arbre à vis
512	Stellmutter	512	Lock nut	512	Ecrou de réglage
512a	Stellmutter	512a	Lock nut	512a	Ecrou de réglage
513	Scheibe	513	Washer	513	Goupille
514	Spannstift	514	Spiral pin	514	Cheville
515	Druckscheibe	515	Thrust washer	515	Rondelle
516	Zylinderschraube	516	Socket head bolt	516	Vis à tête cylindrique
517	Sicherungsring	517	Circlip	517	Circlips
518	Druckscheibe	518	Thrust washer	518	Rondelle
519	Zylinderschraube	519	Socket head bolt	519	Vis à tête cylindrique
520	Sicherungsring	520	Circlip	520	Circlips
521	Zylinderschraube	521	Socket head bolt	521	Vis à tête cylindrique
522	Sechskantmutter	522	Hexagonal nut	522	Ecrou à six pans
523	Zylinderschraube	523	Socket head bolt	523	Vis à tête cylindrique
524	Sechskantmutter	524	Hexagonal nut	524	Ecrou à six pans
525	Zylinderschraube	525	Socket head bolt	525	Vis à tête cylindrique
526	Sechskantmutter	526	Hexagonal nut	526	Ecrou à six pans
527	Gewindebuchse	527	Tapped bushing	527	Taraudage
528	Gewindestift	528	Set screw	528	Vis à tête creuse
529	Gewindestift	529	Set screw	529	Vis à tête creuse
530	Zylinderschraube	530	Socket head bolt	530	Vis à tête cylindrique
532	Distanzbuchse	532	Spacer	532	Douille entretoise
535	Sicherungsring	535	Circlip	535	Circlips
543	Kegelrad	543	Bevel gear	543	Roue conique
544	Verschlußkappe	544	Sealing plug	544	Bouchon
545	Kegelrad	545	Bevel gear	545	Roue conique
549	Zylinderschraube	549	Socket head bolt	549	Vis à tête cylindrique
550	Spannstift	550	Spiral pin	550	Cheville
555	Welle	555	Shaft	555	Arbre
556	Gehäuse	556	Case	556	Carter
557	Buchse	557	Bushing	557	Douille
558	Scheibe	558	Washer	558	Goupille
560	Schneckengetriebemotor	560	Worm geared motor	560	Motoréducteur à roue et vis sans fin
561	Sechskantschraube	561	Hexagon bolt	561	Vis hexagonal
563	Federring	563	Washer	563	Rondelle à ressort
575	Impulsgeber	575	Pulse generator	575	Générateur à ressort
577	Impulsnehmer	577	Pulse sensor	577	Capteur d'impulsions
578	Drehzahlanzeige	578	Speed indicator	578	Indicateur de vitesse
584	Stellungsfernanzeiger	584	Teleindicator	584	Indicateur à distance



Germanischer Lloyd
Certification GmbH 

ZERTIFIKAT

Die Germanischer Lloyd Certification GmbH, 20459 Hamburg, bescheinigt hiermit, dass das Unternehmen

Getriebebau NORD GmbH & Co. KG
Rudolf-Diesel-Straße 1, D-22941 Bargteheide

mit den im Anhang 1 genannten Niederlassungen

für den Geltungsbereich

**Entwicklung, Fertigung und Vertrieb von
Getrieben und Getriebemotoren sowie Zubehör**

ein Qualitätsmanagementsystem eingeführt hat und anwendet.

Durch ein Qualitätsaudit der Germanischer Lloyd Certification GmbH wurde der Nachweis erbracht, dass das Qualitätsmanagementsystem die Forderungen der folgenden Norm erfüllt:

DIN EN ISO 9001:1994

Dieses Zertifikat setzt voraus, dass das Unternehmen sein Qualitätsmanagementsystem nach der angegebenen Norm anwendet und aufrechterhält. Dies wird von der Germanischer Lloyd Certification GmbH überwacht.

Laufzeit verlängert bis zum 14.12.2003
Hamburg, den 14.06.2002

Zertifikat Nr. **QS-082 HH**



GERMANISCHER LLOYD
QUALITY
MANAGEMENT
SYSTEMS
CERTIFICATION

TGA-ZM-07-91-00

(Dr. Weber)

(Dr. P. Schröder)

Dieses Zertifikat gilt nur in Verbindung mit Anhang 1 vom 14.06.2002

Germanischer Lloyd
Certification GmbH 

Anhang 1 vom 14.06.2002
Zertifikat QS-082HH umfasst folgenden Zertifizierungsumfang:

Getriebebau NORD GmbH & Co. KG
Rudolf-Diesel-Straße 1, D-22941 Bargteheide

einschließlich der Standorte:

- **Getriebebau NORD**
Deggendorferstraße 8, A-4030 Linz
- **NORD AANDRIJVINGEN NED. B.V.**
Volstraat 12, NL-2181 HA Hillegom
- **NORD Drivsystem AB**
Ryttargatan 277, S-194 02 Upplands Väsby
- **NORD GEAR Corporation**
800 Nord Drive, Waunakee, U.S.A.-WI 53597-0367
- **NORD Gear Limited**
11 Barton Lane, Abingdon Business Park, GB-Abingdon, Oxfordshire OX 14 3NB
- **NORD Réducteurs Production sarl**
15, Rue Gutenberg, F-68800 Vieux Thann
- **Produktionstechnik NORD GmbH & Co. KG**
Rudolf-Diesel-Straße 5, D-22941 Bargteheide
- **NORD Motorreductores, S.A.**
Ctra. Prats de Llucanes Nave 7, E-08207 Sabadell
- **Montagetechnik NORD GmbH & Co. KG**
Rudolf-Diesel-Straße 1, D-22941 Bargteheide

für den Geltungsbereich:

**Entwicklung, Fertigung und Vertrieb von
Getrieben und Getriebemotoren sowie Zubehör**

TGA-ZM-07-91-00

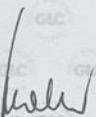

(Dr. Weber)

(Dr. P. Schröder)

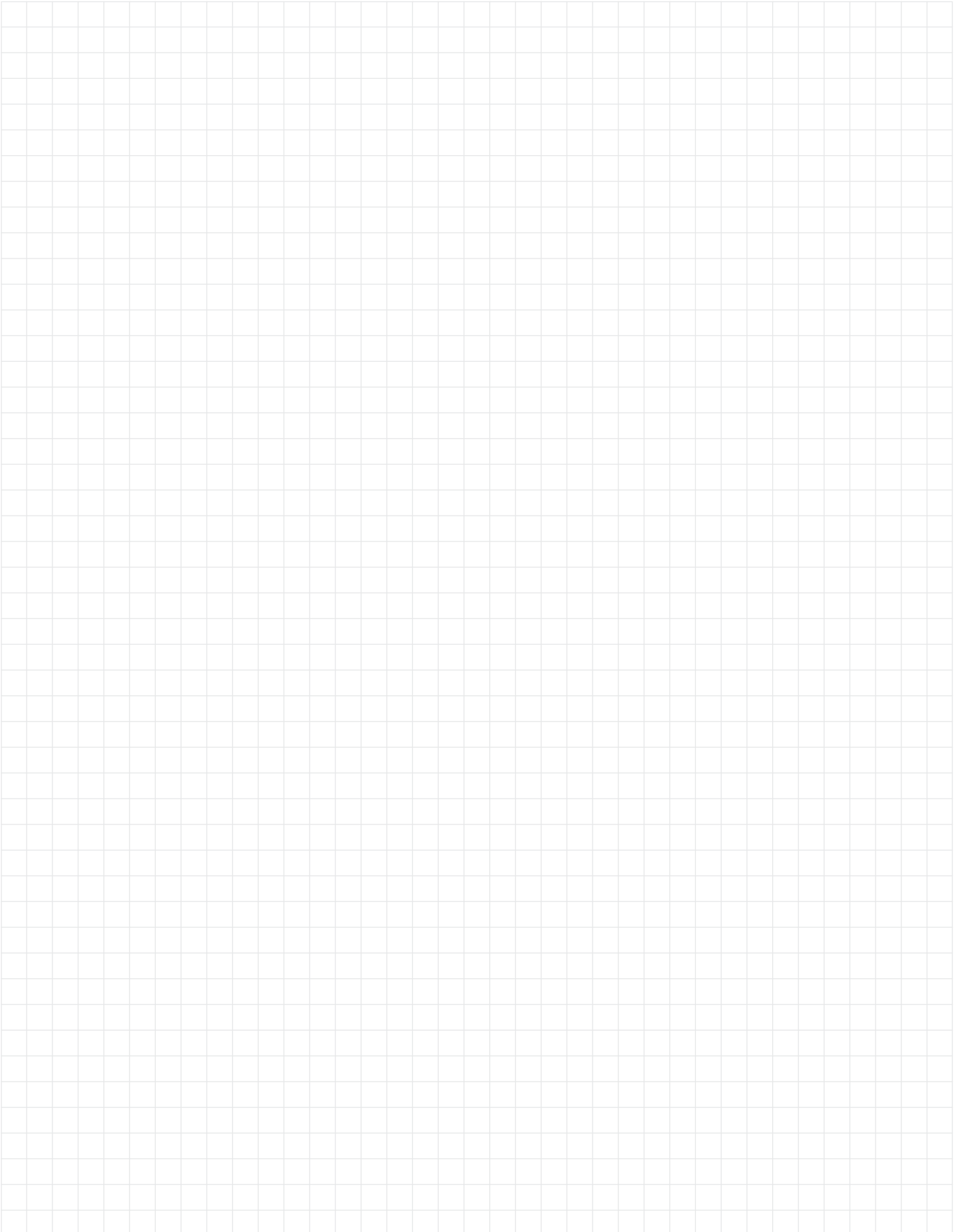

Zertifizierungsverfahren für die weiteren NORD-Tochterbetriebe sind eingeleitet
Certification pending for further subsidiaries
Les procédures de certification pour les autres filiales sont en préparation

**NOTIZEN
NOTES
NOTES**



**NOTIZEN
NOTES
NOTES**



Lieferbedingungen	Unseren Lieferungen und Leistungen liegen unsere Geschäftsbedingungen zugrunde. Änderungen der in diesem Katalog angegebenen technischen Daten sowie Maße und Gewichte bleiben vorbehalten.
Preise	Unsere Preise gelten ab Werk, ausschließlich Verpackung, zuzüglich der gesetzlich vorgeschriebenen Mehrwertsteuer. Soweit der Lieferer nach der Verpackungsordnung verpflichtet ist, die zum Transport verwendete Verpackung zurückzunehmen, trägt der Besteller die Kosten für den Rücktransport. Preisänderungen bleiben vorbehalten. Der Berechnung werden jeweils die am Tage der Lieferung gültigen Preise zugrunde gelegt.

Terms of delivery	Our supplies and services are based on our terms of business. Amendments of technical data as well as of measurements and weights, specified in this catalogue, are reserved.
Prices	Our prices are to be understood ex works, excl. packing, plus the value added tax prescribed by law. Packing will not be taken back. Price alterations are reserved. Invoices will be issued on the basis of those prices, applicable on the date of supply.

Conditions de livraison	Nos fournitures et services sont basés sur nos conditions générales de vente. Sous réserve de modifications des données techniques ainsi que des dimensions et des poids, indiqués au présent catalogue.
Prix	Nos prix s'entendent départ usine, hors taxes, emballage non compris et perdu. Prix sans engagement. La facturation aura lieu au cours du jour.



Maßbilder, Umrisszeichnungen und 3D-Modelle der Getriebe und Getriebemotoren sind im Internet unter **www.nord.com** abrufbar!

Dimensional drawings, true-to-scale drawings and 3D-models of gearboxes and geared motors are available in the Internet: **www.nord.com**

Les plans d'ensemble, les plans à l'échelle 1:1 ou les fichiers 3D des réducteurs et des motoréducteurs peuvent être téléchargés sur le site **www.nord.com**

Anbauelemente im Baukastensystem · Modular elements for modular system · Sous-éléments pour système modulaire

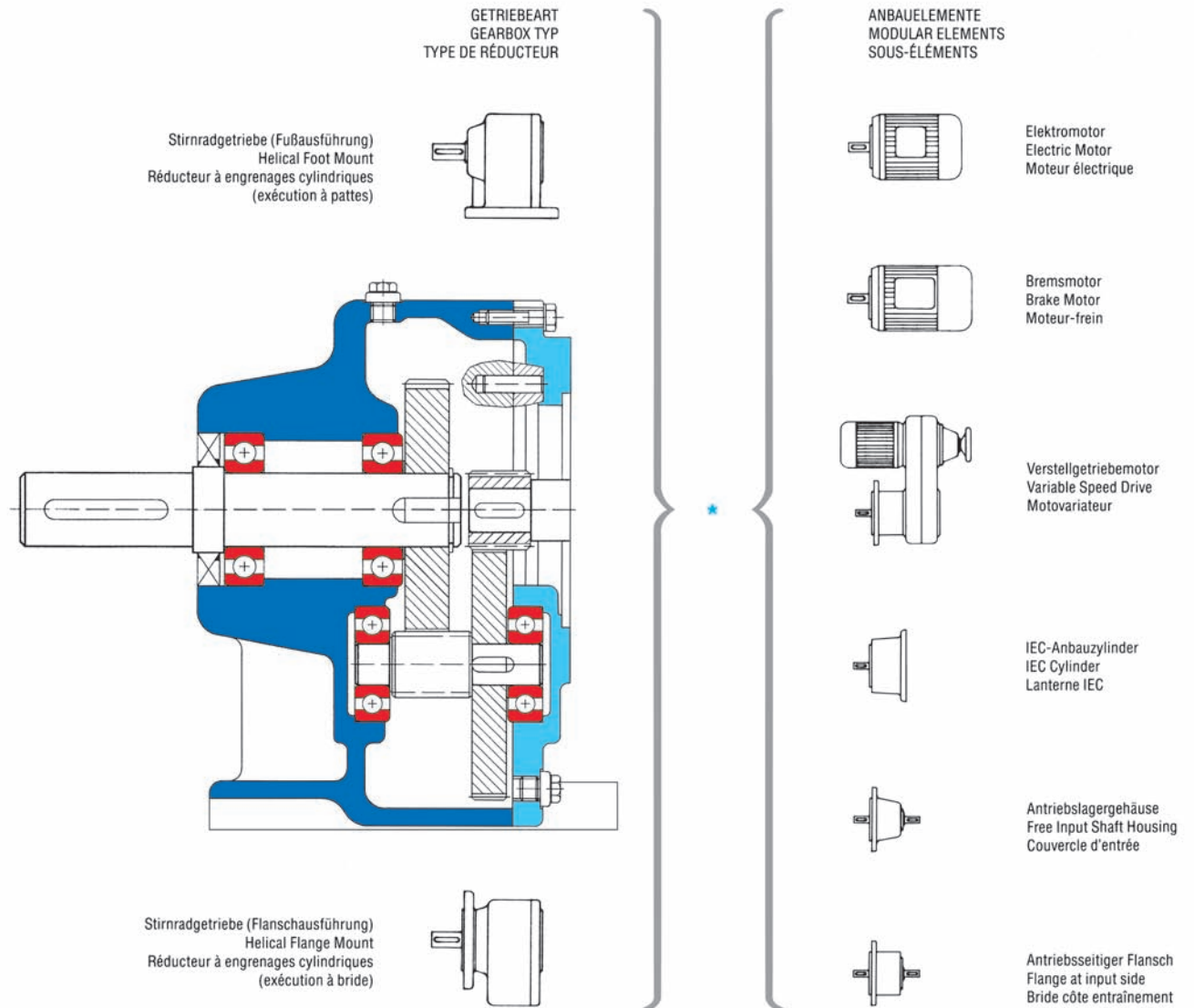

Alle Anbauelemente sind mit sämtlichen Getriebearten kombinierbar.
★ All modular elements can be used in combination with all types of gearboxes.
Tous sous-éléments peuvent être assemblés à tous types de réducteurs.

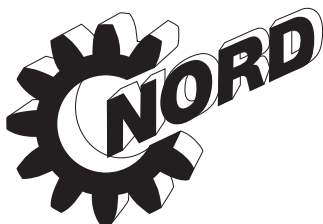

Getriebebau NORD

GmbH & Co. KG

D-22934 Bargteheide/Hamburg · P.O.Box 1262 · Rudolf-Diesel-Str. 1

Telefon 0 45 32 / 4 01-0 · Telefax 0 45 32 / 40 15 55

NORD Internet: <http://www.nord.com>