

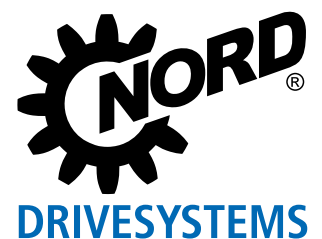

## Drive solutions for the tyre industry

Complete drive solutions from a single source





Industrial gear units



Geared motors



Frequency inverters and motor starters

- ▶ Headquarters and technology centre in Bargteheide near Hamburg.
- ▶ Innovative drive solutions for more than 100 branches of industry.
- ▶ 7 production locations with cutting edge technology produce gear units, motors and drive electronics for complete drive systems from a single source.
- ▶ NORD has 48 subsidiaries in 36 countries and further sales partners in more than 50 countries, providing local stocks, assembly centres, technical support and customer service.
- ▶ More than 4,700 employees throughout the world create customised solutions.



Headquarters in Bargteheide

Motor production

Production and assembly

Motor assembly

Gear unit production

Inverter production

- ▶ System solutions specially customised to the tyre industry
- ▶ Simple commissioning
- ▶ Global NORD network
- ▶ Easy to service and maintain

- ▶ Reduced Total Cost of Ownership (TCO)
- ▶ Modular design
- ▶ Energy savings
- ▶ Project support

## Mixing

The components in the tyre manufacturing process are mixed under the highest temperatures and pressures.

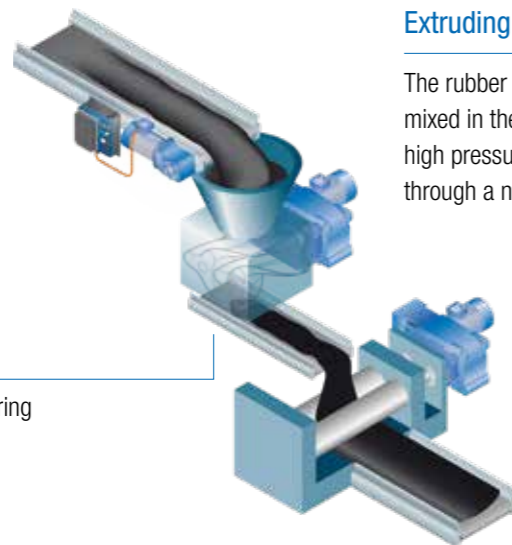

## Extruding

The rubber components are mixed in the extruder under high pressure and then pressed through a nozzle.

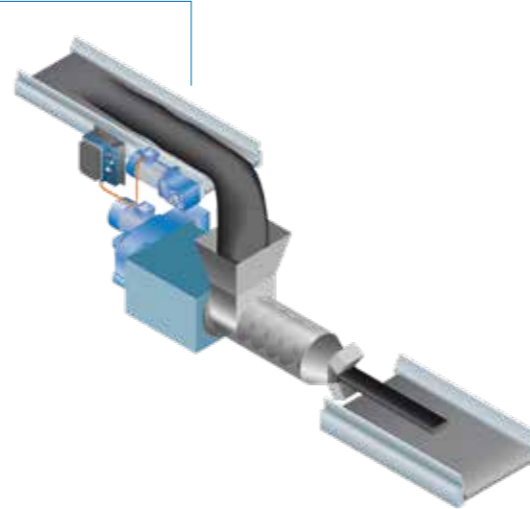

## Calendering

A calender consists of several large diameter rollers, which roll the rubber mass out into thin layers.

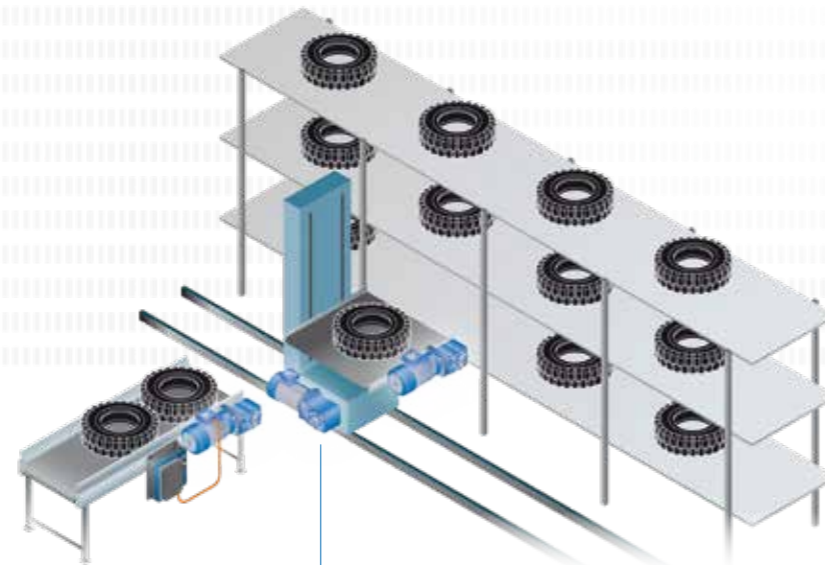
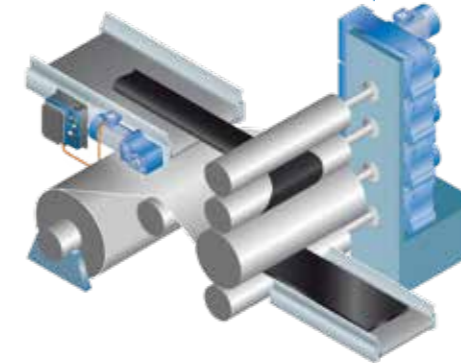

## Intralogistics

Within the factory, the tyres are moved on belt and roller conveyors to their respective processing process or in the warehouse.

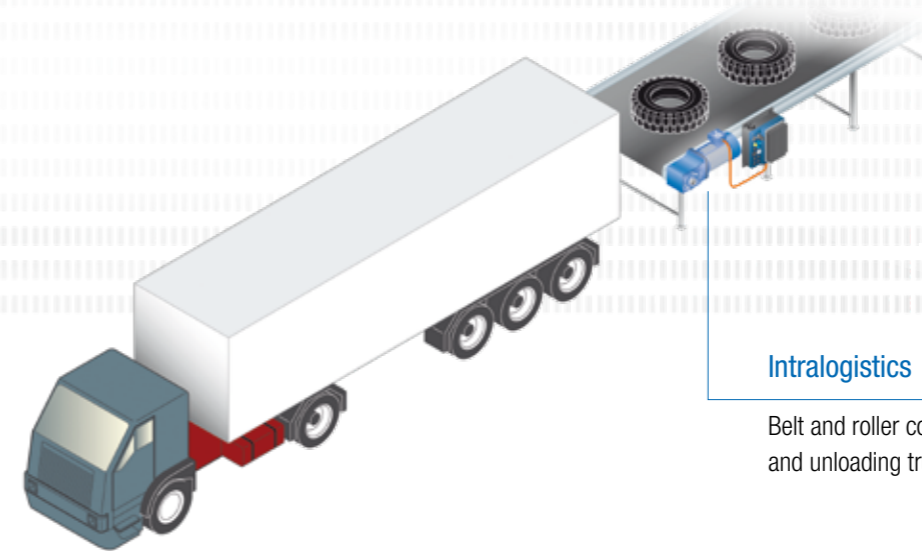

## Intralogistics

Belt and roller conveyors are also used for loading and unloading trucks.

### NORD DRIVESYSTEMS provides:

- ▶ Extensive knowledge of applications and technical support
- ▶ Complete drive solutions from a single source
- ▶ Strong global presence and service
- ▶ Thousands of installed drives in a wide range of applications throughout the world
- ▶ Wide range of products with high quality standards
- ▶ Great reliability, economy and service life
- ▶ Recognised product quality compliant with international standards

# Drive solutions for the tyre industry

## We support you with:

We are thoroughly familiar with the requirements of your branch of industry. We place a high value on long-term cooperation with our customers and partners. You can be certain that we will use our entire expertise to strengthen the reputation of your brand.

- |   |   |  |
|---|---|--|
| <p><b>Design</b></p> <ul style="list-style-type: none"> <li>▶ myNORD</li> <li>▶ Reduced number of variants</li> <li>▶ Project design / optimisation</li> <li>▶ Drive system design</li> <li>▶ Application solutions</li> <li>▶ Green solutions</li> <li>▶ CAD drawings</li> </ul> | <p>→</p> <p><b>Commissioning</b></p> <ul style="list-style-type: none"> <li>▶ Plug-and-Play</li> <li>▶ Support</li> <li>▶ Training</li> <li>▶ Documentation</li> <li>▶ Smart commissioning</li> </ul> | <p>→</p> <p><b>Service</b></p> <ul style="list-style-type: none"> <li>▶ Predictive maintenance (PLC function)</li> <li>▶ Spare parts, express shipping</li> <li>▶ Global presence</li> <li>▶ 24/7 Support</li> </ul> |
|---|---|--|

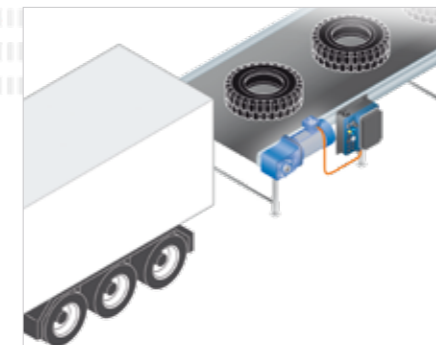
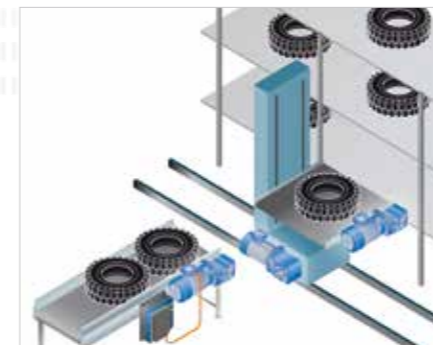
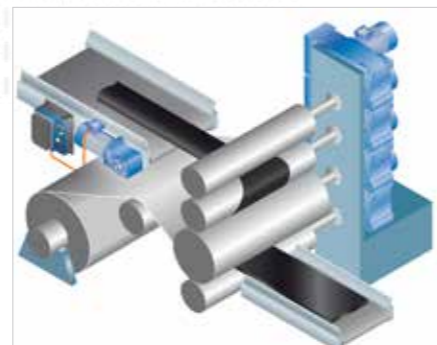
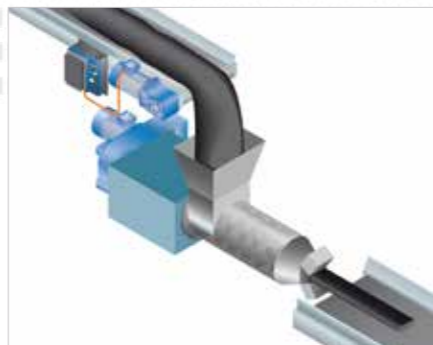

## Mixing

The tyre production process starts by mixing the components. They are mixed at high temperatures and pressures to obtain an homogeneous mass.

- ▶ Compact design
- ▶ Robust housing with high torque capacity
- ▶ Reinforced bearings with increased spacing as option
- ▶ Various output versions for adaptation to different mixing applications

## Extruding

An extruder consists of an extruder cylinder and an extruder screw. The rubber components are mixed in the extruder under high pressure and then pressed through a nozzle.

- ▶ Special extruder flange for highest axial forces
- ▶ Versatile output shaft versions according to customers requirements

## Calendering

A calender consists of several large diameter rollers, which roll the rubber mass out into thin layers. Depending on the requirements, a layer of textile or steel threads can be inserted between the layers.

- ▶ Versatile mounting
- ▶ Compact design enables simple stacking of multiple gear units

## Intralogistics

Within the factory, the tyres are moved on belt and roller conveyors. The plant includes elevators, inclined conveyors and direction switches, as well as overhead conveyors.

- ▶ Reduction of variants for smaller local spare parts stocks
- ▶ Fully decentralised drive units with motor or wall mounted frequency inverters
- ▶ Energy efficient drive units
- ▶ Plug-and-Play inverters
- ▶ Easy maintenance and repair

Efficient, reliable and maintenance-friendly drive solutions from a single source



## Energy efficient

NORD drive solutions are environmentally friendly and help to reduce operating costs and minimise CO<sub>2</sub> emissions.

- ▶ Highly efficient helical and bevel gear units achieve optimum power transmission performance.
- ▶ NORD motors comply with international energy efficiency classes.
- ▶ NORD frequency inverters have energy saving functions to effectively reduce energy consumption.

## Reduced number of variants

Careful and intelligent selection of NORD drive units reduces the number of variants and therefore inventory and spare parts costs.

- ▶ Reduction of the number of variants reduces operating costs, e.g. for servicing and maintenance and therefore reduces costs for the customer (TCO).
- ▶ The modular system simplifies engineering and commissioning.

## Reliable

Reliability is our main focus when developing our drive solutions. All of our system components are precisely matched to each other and ensure smooth operation.

- ▶ UNICASE gear units ensure precise positioning of bearings and shafts.
- ▶ The gear units are extraordinarily robust, run very quietly and have a particularly long service life.
- ▶ NORD frequency inverters are equipped with safety functions to protect the drive system electronically.

## Easy to service and maintain

Thanks to their plug connections and modular structure, NORD drive units are especially easy to service and maintain. They therefore help to reduce down times and increase plant availability.

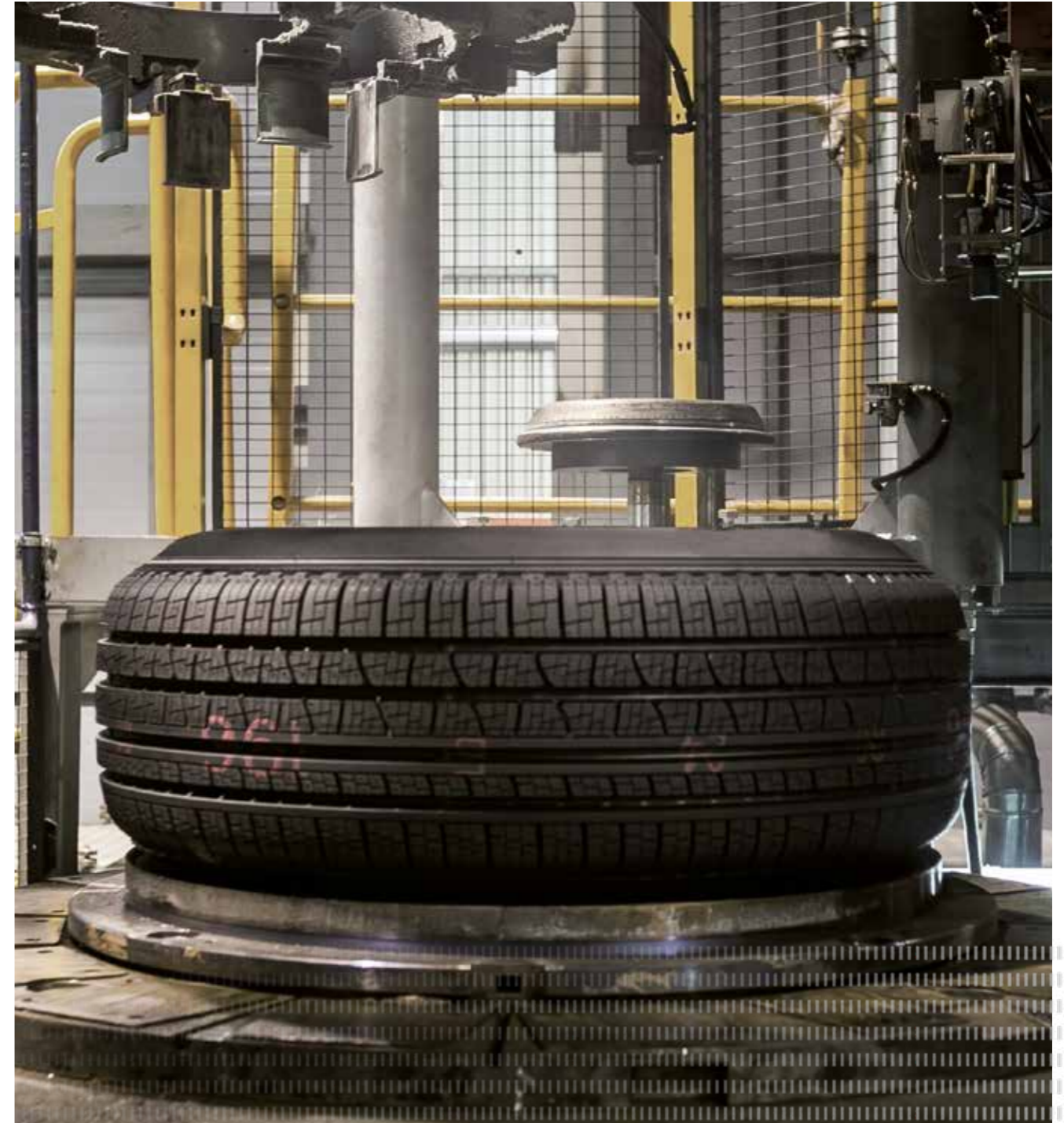

# Drive solutions for the tyre industry

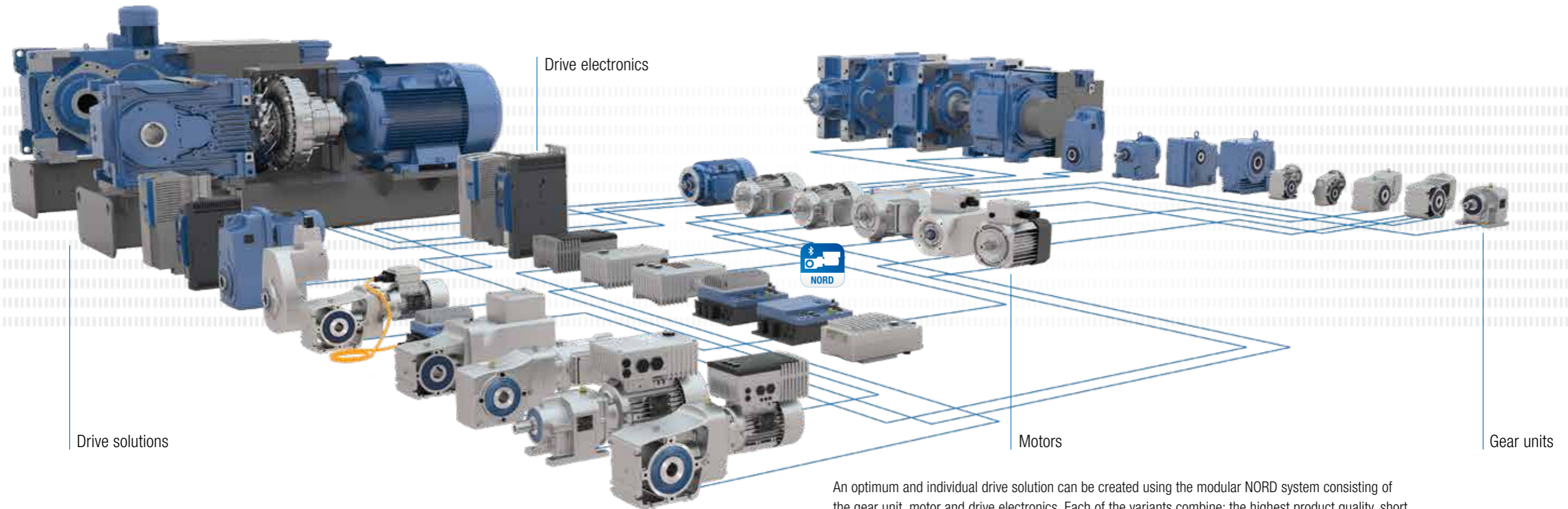

An optimum and individual drive solution can be created using the modular NORD system consisting of the gear unit, motor and drive electronics. Each of the variants combine: the highest product quality, short planning and assembly times, high delivery availability, and a good price/performance ratio.



Reliable gear units with one-piece UNICASE housing can cater for any load.

- ▶ High power density
- ▶ Long service life



Powerful motors keep drive systems in motion in all operating situations.

- ▶ Designed in compliance with international standards
- ▶ High overload capacity
- ▶ Energy efficient



Intelligent drive electronics provide exactly the control options which you need.

- ▶ Scalable functions
- ▶ Full field bus connection facilities
- ▶ Wide power range
- ▶ PLC integrated at no extra cost



Extensive communication options enable access to drives from all levels to enable a wide variety of setting options.

- ▶ All common bus systems
- ▶ Quick and simple commissioning with plug-in control box or using NORDCON software
- ▶ Convenient hand held console for local operation
- ▶ Optionally with intralogistics options



Switches and keys are located directly on the drives and enable direct starting and stopping as well as mode switching.

- ▶ Mains switch
- ▶ Selector switch for local or remote control
- ▶ Start/Stop and Forward/Reverse switch
- ▶ Energy efficient



All interfaces are designed for ease of use. Drives can be easily configured and installed.

- ▶ Simple Plug-and-Play with all common connection plugs
- ▶ Plug-in supply cable and motor output
- ▶ Plug-in sensors and encoders
- ▶ Pre-assembled cables
- ▶ PLC integrated at no extra cost

## MAXXDRIVE® industrial gear units (Catalogue G1050)



- ✓ Parallel and angled gear units
- ✓ Foot mounted motor (IEC B3)
- ✓ Flanged motor (IEC B5)
- ✓ Special bearings for axial forces (VL5)
- ✓ Compact design
- ✓ Various internal or external cooling options
- ✓ Customised design of flange connection and shaft geometry

Sizes: 11  
 Power: 1.5 – 6,000 kW  
 Torque: 15,000 – 282,000 Nm  
 Speed ratio: 5.54 – 30,000:1

Due to their compact design and modular structure, NORD industrial gear units are the ideal solution for your applications for mixing, extruding and calendaring.

Users do not just need drive components, but rather complete solutions and functioning systems.

### Industrial gear unit moduls

Because of this, NORD DRIVESYSTEMS pursues a consistent system philosophy, which is reflected in the perfectly matched modules of our range of industrial gear units. The optimally matched individual components form the basis for a wide range of versions, great flexibility and short planning and installation times. This enables the drive solutions to be individually tailored to the customer's requirements with short delivery times, even for large gear units.

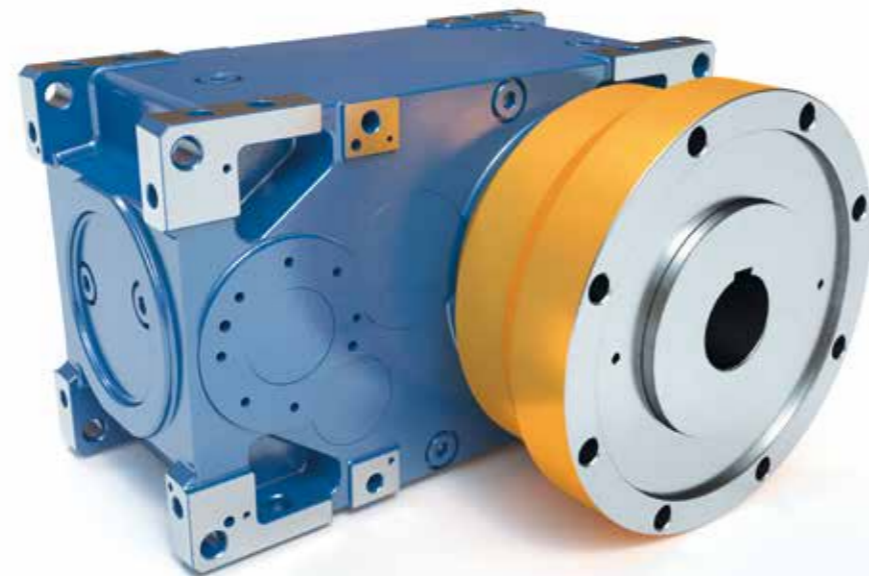

## The ideal solution for servo applications

A servo drive unit is a drive unit with electronic control of the position, speed or torque, with exceedingly high demands for dynamics, adjustment range and/or precise movement.

### NORD DRIVESYSTEMS supplies drive solutions consisting of:

- ▶ Motors
  - ▶ Asynchronous motors (ASM)
  - ▶ Permanent magnet synchronous motors (PMSM)
- ▶ Gear units
- ▶ Drive electronics
- ▶ Accessories (cables, plug connectors, encoders) for a wide range of servo applications

All components are from the NORD product range and therefore provide great advantages with regard to costs and flexibility.

Applications such as positioning, synchronous operation or winding can normally be implemented from the NORD product range.

Please contact us for solutions from NORD DRIVESYSTEMS if you use servo drives.

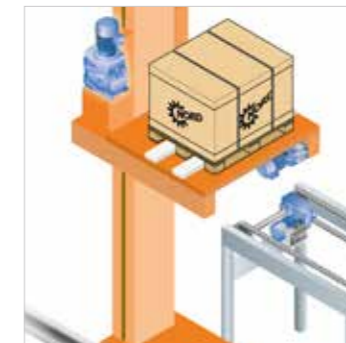

### Drives for positioning applications

- ▶ Storage and retrieval devices
- ▶ Lifting platforms, lifting systems
- ▶ Overhead and portal cranes
- ▶ Stacking and palletising systems
- ▶ Turntables

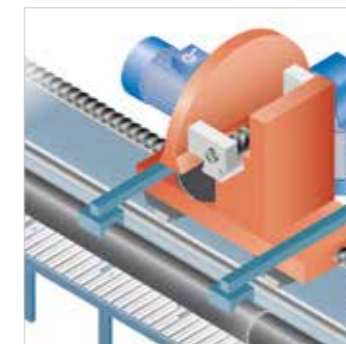

### Drives for synchronised applications/ axis coordination

- ▶ Lifting stations
- ▶ Rolling, drawing and stretching
- ▶ Conveying and alignment of endless materials
- ▶ Cross cutters
- ▶ Flying saw
- ▶ Linear XYZ portal systems

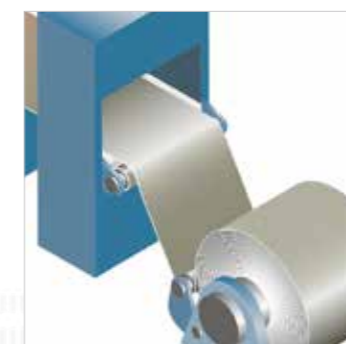

### Drives for winding applications

- ▶ Winders and unwinders for various materials
- ▶ Paper roll handling: longitudinal cutters, laminators, etc.
- ▶ Coordinated cutting blade

# Drive solutions for the tyre industry

The ideal solutions for intralogistics in the tyre industry

## LogiDrive®

- ▶ Highly efficient 2-stage bevel gear unit
- ▶ Permanent magnet synchronous motor (PMSM)
- ▶ Power plug connector
- ▶ Signal connector
- ▶ Incremental encoder (optional)
- ▶ Pre-assembled cables
- ▶ High overload capacity
- ▶ Motor power 1.1 – 5.5 kW



### NORDAC LINK Field Distribution System

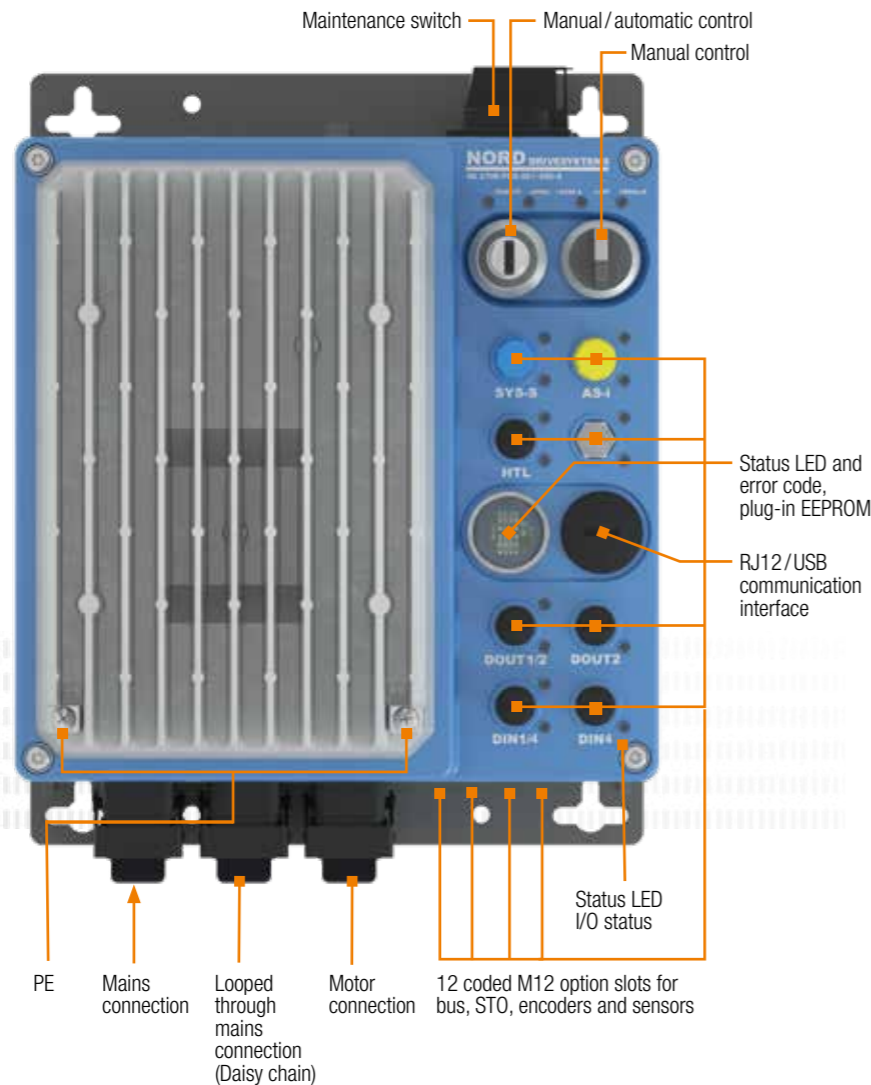

### High efficiency motors

The IEC 60034-30 standard specifies the efficiency requirements for motors. NORD permanent magnet synchronous motors meet and exceed these standard requirements. With their high efficiency and excellent performance, our motors increase the energy efficiency of your plant.



IE3 Standard  
Operating costs:  
52 Euro / month\*



LogiDrive  
Operating costs:  
27 Euro / month\*  
(up to 50 % saving)

\* Assumption:  
0.10 Euro kWh / 1.5 kW / partial load /  
24h continuous operation



### Total operating costs

Our LogiDrive utilises its full potential in applications which are characterised by partial loads and low speeds. Use of synchronous motors enables considerable cost savings in tyre production.

Over its entire lifespan, the LogiDrive solution produces large cost savings and rapidly achieves profitability with only a low additional investment.

### LogiDrive means energy efficiency

- ▶ By compliance with the most stringent energy efficiency directives
- ▶ Due to considerably reduced total operating costs
- ▶ Due to highly efficient, even in partial load ranges and at low speeds thanks to PMSM technology

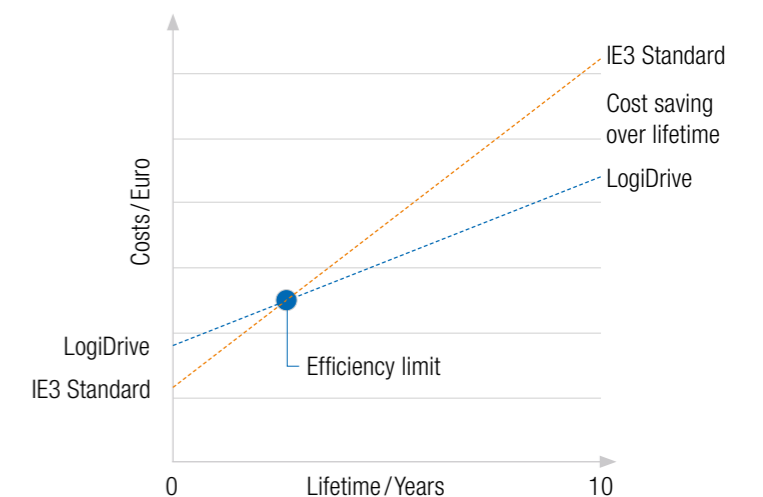



Headquarters:  
Getriebbau NORD GmbH & Co. KG  
Getriebbau-Nord-Str. 1  
22941 Bargteheide, Germany  
T: +49 45 32 / 289 0  
F: +49 45 32 / 289 22 53  
info@nord.com