

**Drive solutions for  
the food and beverage industry**  
Complete drive solutions from a single source

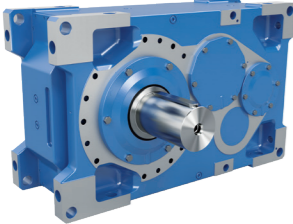

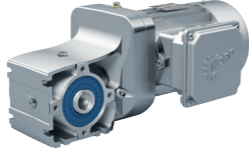

Industrial gear units



Geared motors



Frequency inverters and motor starters

- ▶ Headquarters and technology centre in Bargteheide near Hamburg.
- ▶ Innovative drive solutions for more than 100 branches of industry.
- ▶ 7 production locations with cutting edge technology produce gear units, motors and drive electronics for complete drive systems from a single source.
- ▶ NORD has 48 subsidiaries in 36 countries and further sales partners in more than 50 countries, providing local stocks, assembly centres, technical support and customer service.
- ▶ More than 4,900 employees throughout the world create customised solutions.



Headquarters in Bargteheide



Gear unit production



Inverter production



Motor production



Production and assembly



Motor assembly



## From processing to packaging

NORD DRIVESYSTEMS is a global leader in drive solutions for food and beverage industry applications around the world. NORD is a driving force in the production of:

- ▶ Fresh foods
- ▶ Dried and snack food
- ▶ Bakery products
- ▶ Ready meals
- ▶ Confectionary products
- ▶ Beverages
- ▶ Liquid and canned foods

## NORD DRIVESYSTEMS provides:

- ▶ Comprehensive application knowledge and technical support
- ▶ Complete drive solutions from a single source
- ▶ Strong global presence and support
- ▶ Thousands of installed units in the food and beverage industry
- ▶ Extensive, versatile portfolio of premium quality products
- ▶ High reliability, efficiency and durability
- ▶ Recognised production quality according to global standards



## Pumping

NORD DRIVESYSTEMS provides dedicated pump drives with special functions.

- ▶ High starting torques/soft starts as required
- ▶ Wall or motor mounted inverters
- ▶ H1 food-grade oil for gear lubrication
- ▶ Safe terminal or plug connections

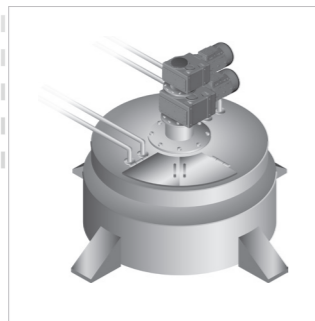

## Mixing, agitating, kneading

NORD provides heavy-duty geared motors for agitators of any scale.

- ▶ Extra-strong output shaft bearings for heavy loads
- ▶ Temperature sensors for overheating protection
- ▶ Programmable inverters for STO and reverse operation
- ▶ Twin gearbox agitators with shafts turning in opposing directions

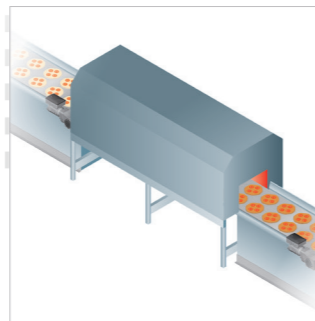

## Heating, cooling, freezing

NORD provides drive solutions adapted to extreme temperatures.

- ▶ Various fan/fan-less configurations
- ▶ H1 low-/high-temperature food-grade oils, hydrophobic bearing lubricants
- ▶ Condensation drains
- ▶ Stainless steel fittings

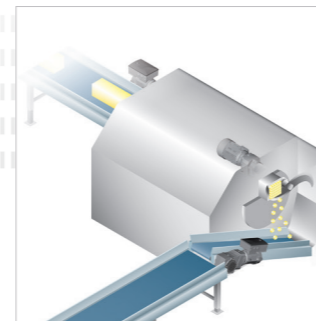

## Cutting, slicing, dosing

NORD provides systems for CIP area installation and machine integration.

- ▶ Smooth wash-down surfaces on all drive components
- ▶ FDA-compliant sealed aluminium surface tolerating pH 2–12
- ▶ Stainless steel fittings
- ▶ IP66 or optional IP69K ingress protection

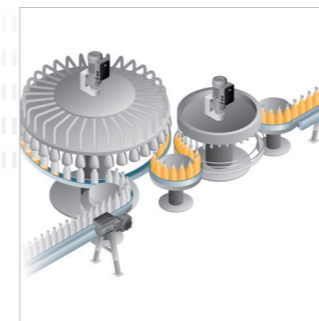

## Bottling

NORD provides drives tailored to filling and conveying systems.

- ▶ Absolute and incremental encoders
- ▶ Plug-and-play connections
- ▶ Smooth surfaces
- ▶ High-quality paints or sealed surfaces for easy cleaning

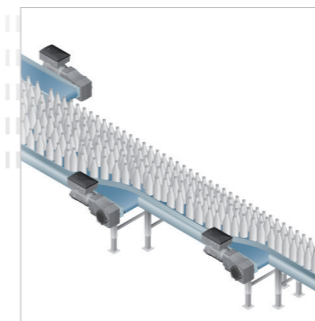

## Conveying

NORD provides versatile solutions for horizontal, vertical and inclined conveyors.

- ▶ Encoders for precise positioning
- ▶ Energy-saving inverters for cabinet, wall or motor mounting
- ▶ High-quality paints or sealed surfaces for easy cleaning
- ▶ Soft start, deceleration ramp and STO functions

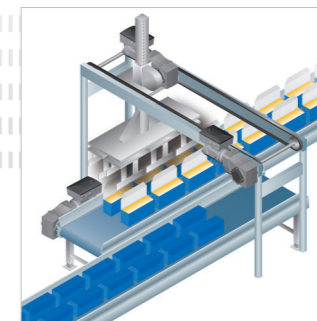

## Secondary packaging

NORD provides highly efficient systems for intermittent and continuous operation.

- ▶ Compact overall size, plug-and-play connections
- ▶ Inverters for motor mounting or wall mounting
- ▶ Encoders for precise positioning
- ▶ High-quality paints or sealed surfaces for easy cleaning

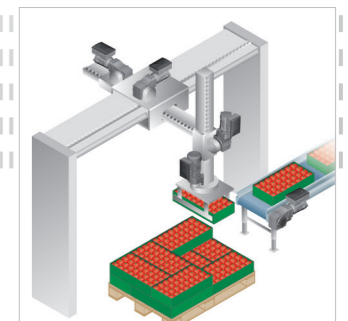

## Palletising

NORD provides precise positioning and dynamic motion solutions.

- ▶ Compact, lightweight aluminium drive units
- ▶ Cabinet-installed and motor mounted inverters for positioning with encoder feedback
- ▶ High-quality paints or sealed surfaces for easy cleaning
- ▶ Soft start, deceleration ramp, brake and STO functions

# Drive solutions for the food and beverage industry

Efficient, reliable and proven drive solutions from a single source



## Efficient

NORD drive solutions are environmentally friendly and help to minimise CO<sub>2</sub> emissions.

- ▶ NORD low inertia motors are designed for inverter operation and meet the latest international energy requirements.
- ▶ NORD frequency inverters ensure efficient operation, improved process control and optimum motor power.
- ▶ Service and maintenance-friendly NORD drives reduce downtimes and therefore contribute to greater efficiency and availability of the entire system.

## Reliable

It is vital to prevent breakdowns in the food industry. For this reason, reliability is our main focus when developing drive solutions. All of our system components are precisely matched to each other and ensure smooth operation.

- ▶ Gear units with UNICASE housings provide precise positioning of bearings and drive shafts.
- ▶ AUTOVENT ensures leak-free design.
- ▶ Precision-made gears with minimal wear are used throughout.
- ▶ The gear units are extraordinarily robust, run very quietly and have a particularly long service life.
- ▶ NORD inverters protect the drive system electronically and are able to visualise the operating data.

## Proven

The reliability and cost-effectiveness of electronically controlled NORD DRIVESYSTEMS conveyor drives have proven themselves in intralogistics throughout the world. The systems combine great flexibility and a graduated comprehensive range of functions with convenient operation. NORD drives ensure particularly high conveyance speeds that are more and more often required due to increased safety measures.

- ▶ Mechatronic drive systems from NORD are based on lightweight and highly efficient 2-stage bevel geared motors.
- ▶ In combination with wall or motor mounted frequency inverters, they form efficient drive systems. NORD DRIVESYSTEMS also supplies the required cable connectors and interfaces to a variety of bus systems as well as the respective software.

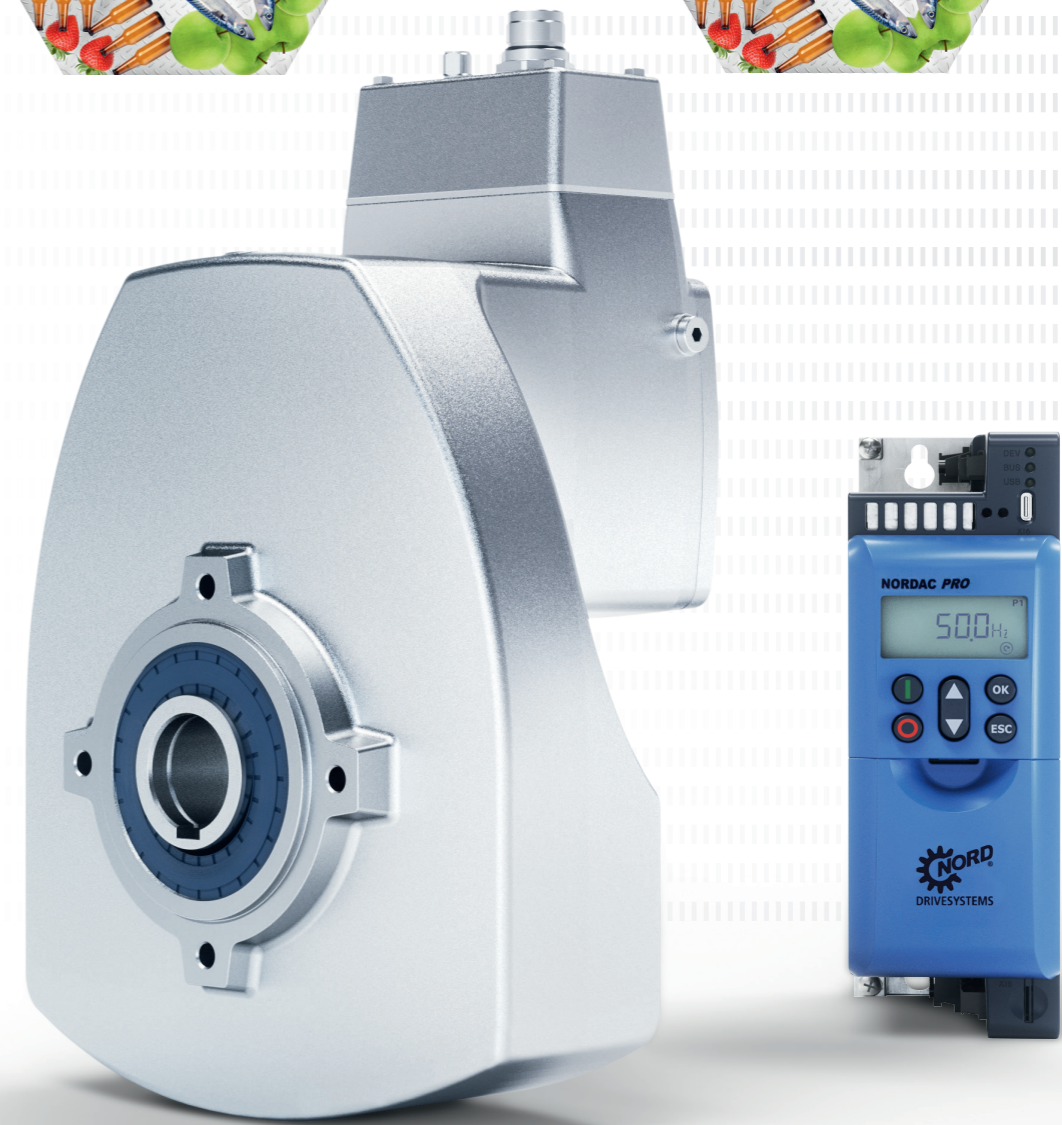
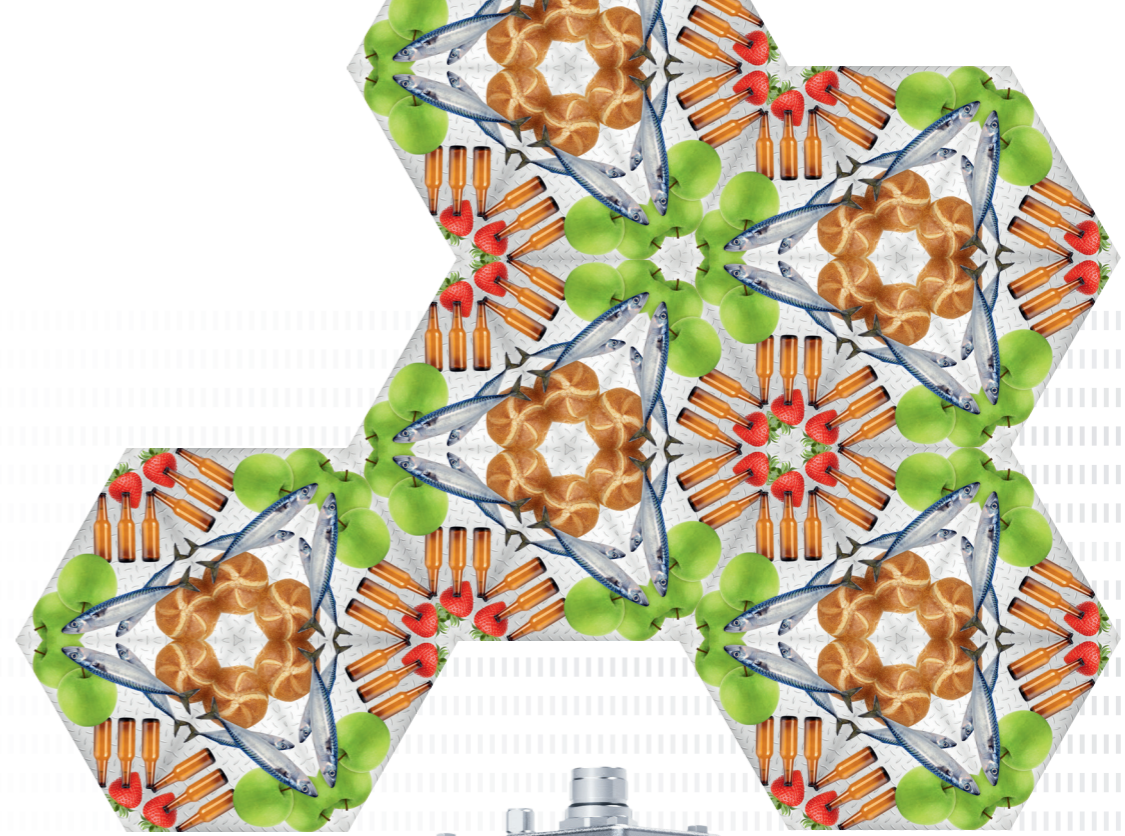

## MAXXDRIVE® industrial gear units (Catalogue G1050)

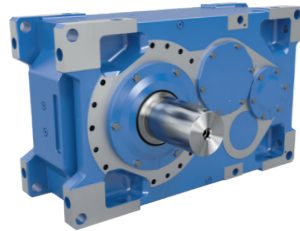

- ✓ Parallel and angled gear units
- ✓ High precision axis alignment
- ✓ Long life, low-maintenance
- ✓ UNICASE housing

Sizes: 11  
 Power: 1.5 – 6,000 kW  
 Torque: 15,000 – 282,000 Nm  
 Speed ratio: 5.54 – 30,000:1

## UNICASE helical in-line gear units (Catalogue G1000)

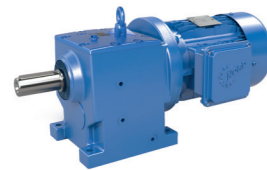

- ✓ Foot or flange mounted
- ✓ Long life, low-maintenance
- ✓ Optimum sealing
- ✓ UNICASE housing

Sizes: 11  
 Power: 0.12 – 160 kW  
 Torque: 10 – 26,000 Nm  
 Speed ratio: 1.35 – 14,340.31:1

## UNICASE parallel shaft gear units (Catalogue G1000)

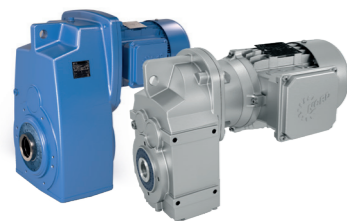

- ✓ Foot, flange or face mounted
- ✓ Hollow or solid shaft
- ✓ Compact design
- ✓ UNICASE housing

Sizes: 15  
 Power: 0.12 – 200 kW  
 Torque: 110 – 100,000 Nm  
 Speed ratio: 4.03 – 15,685.03:1

## NORDBLOC.1® 2-stage bevel gear units (Catalogue G1014)

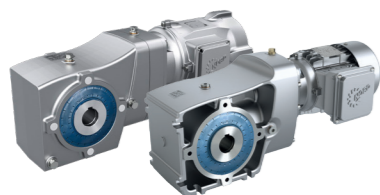

- ✓ Foot, flange or face mounted
- ✓ Hollow or solid shaft
- ✓ Aluminium housing

Sizes: 6  
 Power: 0.12 – 9.2 kW  
 Torque: 50 – 660 Nm  
 Speed ratio: 3.03 – 70:1

## UNIVERSAL SI worm gear units (Catalogue G1035)

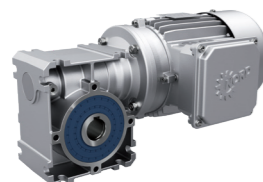

- ✓ Modular
- ✓ Universal mounting options
- ✓ Life-long lubrication
- ✓ IEC version

Sizes: 5  
 Power: 0.12 – 4.0 kW  
 Torque: 21 – 427 Nm  
 Speed ratio: 5.00 – 3,000:1

## NORDAC START SK 135E motor starters (Catalogue E3000)

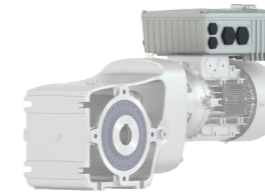

- ✓ Integrated electronic brake rectifier
- ✓ Consistent parameter structure
- ✓ Reversing starter with soft start function

Sizes: 2  
 Voltage: 3 ~ 200 – 240 V, 3 ~ 380 – 500 V  
 Power: 0.12 – 3 kW resp. up to 7.5 kW

## NORDAC BASE SK 180E frequency inverters (Catalogue E3000)

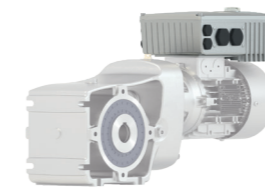

- ✓ Stand-alone operation
- ✓ 4 parameter sets
- ✓ Sensorless current vector control (ISD control)
- ✓ Integrated PLC

Sizes: 2  
 Voltage: 1 ~ 110 – 120 V, 1 ~ 200 – 240 V, 3 ~ 200 – 240 V, 3 ~ 380 – 500 V  
 Power: 0.25 – 2.2 kW

## NORDAC PRO SK 500E frequency inverters (Catalogue E3000)



- ✓ Stand-alone operation
- ✓ 4 parameter sets
- ✓ Sensorless current vector control (ISD control)
- ✓ Integrated PLC

Sizes: 11  
 Voltage: 1 ~ 110 – 120 V, 1 ~ 200 – 240 V, 3 ~ 200 – 240 V, 3 ~ 380 – 480 V  
 Power: 0.25 – 160 kW

## Transportable wine pump with frequency inverter SK 200E



- ✓ No need for shielded power cable
- ✓ Fast commissioning
- ✓ Ready-to-use motorinverter unit
- ✓ Reduction in design time
- ✓ No special cable routing
- ✓ No integration into cabinet necessary
- ✓ Local machine control

Headquarters:  
Getriebbau NORD GmbH & Co. KG  
Getriebbau-Nord-Str. 1  
22941 Bargteheide, Germany  
T: +49 45 32 / 289 0  
F: +49 45 32 / 289 22 53  
info@nord.com