

**Drive solutions for
baggage handling systems**
Complete drive systems from a single source

**NORD**[®]
DRIVESYSTEMS
Our Solution. Your Success.

Complete drive solutions from a single source



NORD Delivers

NORD offers first-class customer service and support along with full-featured drive solutions that can tackle the toughest requirements. All components are carefully selected and precisely configured to meet your exact specifications. In the rare case that standard components won't meet your needs, our in-house engineering team will work with you to design custom components or a complete customized system.

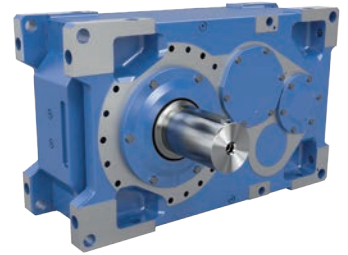

Reduce Lead Times and Decrease Inventory

- ▶ Fastest lead times in the industry with NO expedite fees
- ▶ Over 20,000,000 standard configurations to reduce or eliminate the need for custom components
- ▶ Modular drives, motors, and electronic controls minimize inventory of replacement units and parts



Global Product Designs, Standards, and Support

- ▶ Innovative, industry-standard products to support a wide range of applications
- ▶ Global sales and support network
- ▶ Dedicated mechanical and electrical application engineers ready to assist you
- ▶ Online resources available to you any time
- ▶ 24/7/365 emergency breakdown service

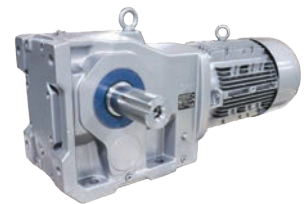

Increase Efficiency and Reduce Operation Costs

- ▶ myNORD online tools for fast selection, configuration, ordering, and tracking of your drive units
- ▶ Drive systems that are perfectly matched to your application for optimum performance and energy efficiency
- ▶ Program personalization, such as weekly shipment schedules and custom nameplates
- ▶ Partner with a company that is easy to do business with and wants to see you succeed!



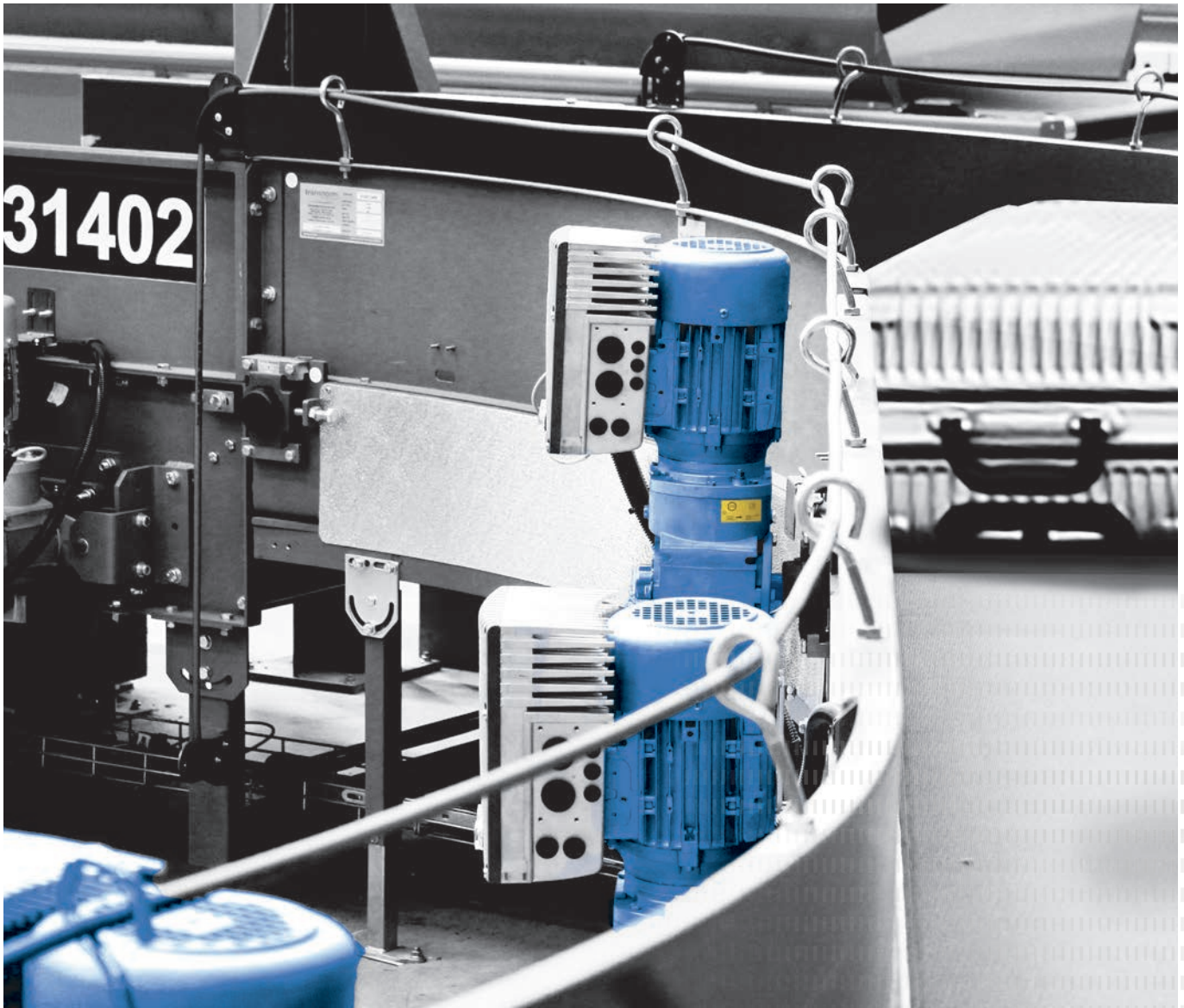

NORD offers integrated solutions for the special requirements of baggage handling applications

- ▶ System solutions engineered to meet airport requirements
- ▶ Simple commissioning
- ▶ Global service and support network
- ▶ Plug-and-play systems
- ▶ Easy maintenance, service-friendly designs
- ▶ Lower total cost of ownership over product service life
- ▶ Standardized units to reduce system variants
- ▶ Innovative, energy-efficient systems
- ▶ Direct project support

Drive solutions for baggage handling systems

Check-in

Drive solutions from NORD are characterized by their long service life, high-efficiency, and quiet operation to effectively and discretely transport baggage from the check-in counter to the flight operations area.

Lifts

NORD's decentralized variable frequency drives with encoder feedback ensure exact positioning with high dynamics for lifts, S-conveyors, and C-conveyors.

Inclined conveyors

Standardized yet flexible gear units, brake motors, and decentralized variable frequency drives with external braking resistors are available to overcome minor height differences between inclined conveyors.

NORD DRIVESYSTEMS is a leading airport industry drive system manufacturer with innovative solutions utilized for baggage handling and transport worldwide. Whether for check-in, sorting, high-speed transport, or baggage reclaim - NORD offers configurable drive systems that meet the specialized requirements of every baggage handling system application.

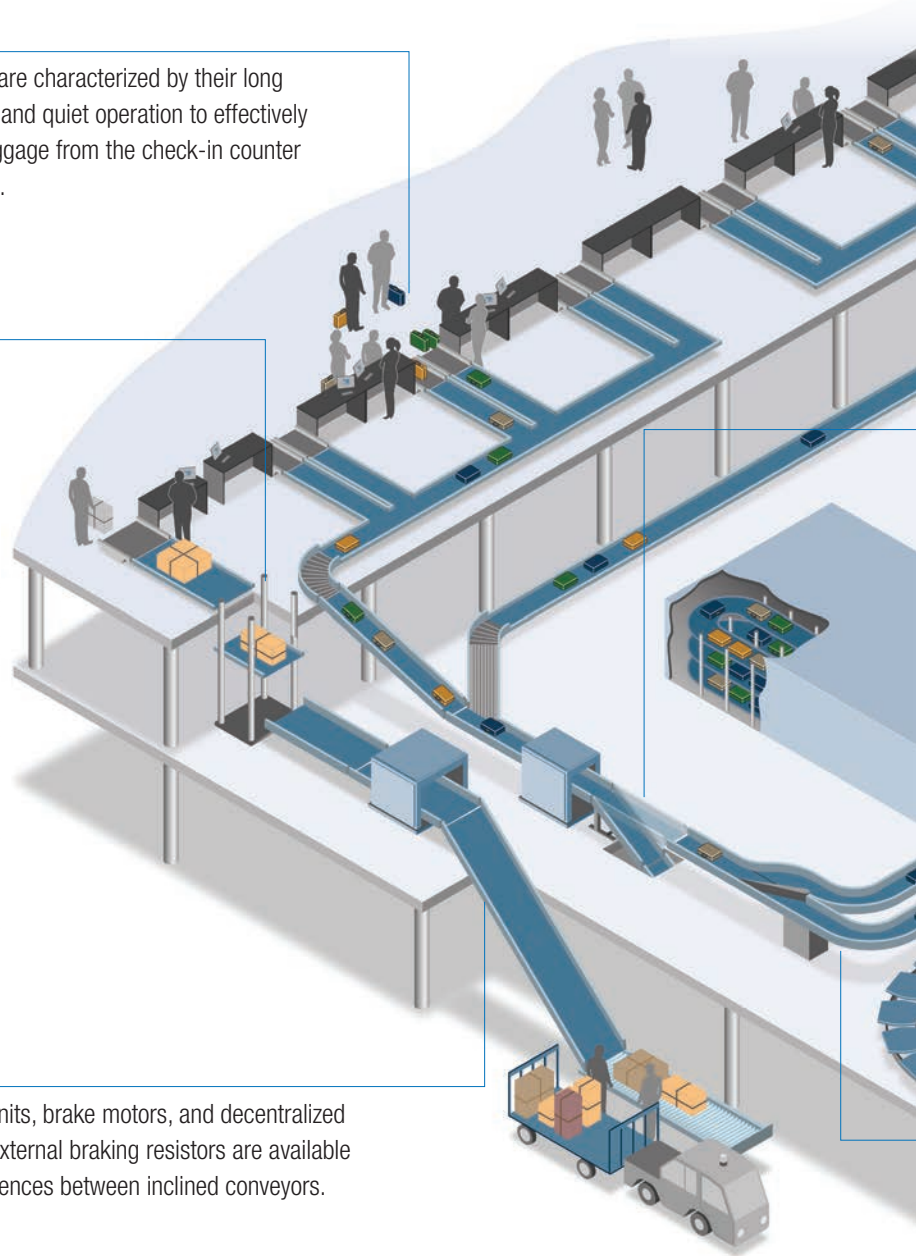

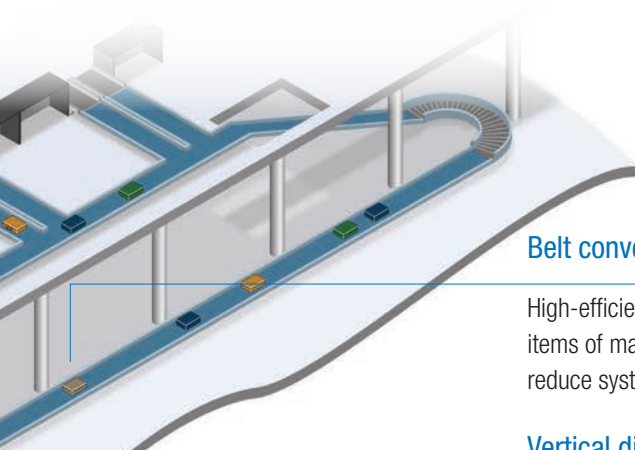

Belt conveyors

High-efficiency geared motors ensure superior transport of baggage items of many shapes in all directions. NORD's drive solutions can reduce system variants and are easy to service and maintain.

Vertical diverters

Vertical sorting is an economical process for areas with limited floor space and high volumes. Compact gear units paired with highly dynamic synchronous motors from NORD ensure sorting processes are fast and efficient.

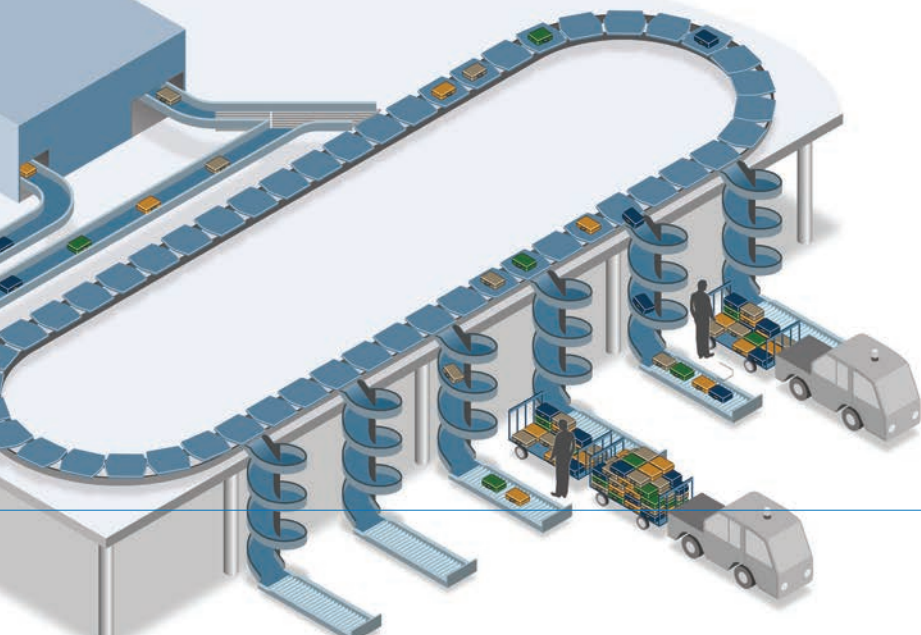

Merger conveyors

NORD offers synchronous and asynchronous motors with high overload capacity and dynamic operation to keep pushers and indexers running smoothly.

NORD DRIVESYSTEMS provides:

- ▶ Extensive application knowledge and expert technical support
- ▶ Complete drive solutions from a single source
- ▶ Strong global presence for service and support
- ▶ Thousands of installed drives in the airport industry
- ▶ Wide range of products with high quality standards
- ▶ Great reliability, economy, and service life
- ▶ Recognized product quality compliant with international standards

Drive solutions for baggage handling systems

From start to finish

NORD DRIVESYSTEMS develops and manufactures scalable drive solutions for all areas of baggage handling at national and international airports – from baggage drop-off at check-in to baggage reclaim.

- ▶ Energy efficient and high overload capacity drives for belt and inclined conveyors
- ▶ Precisely positioned, highly dynamic drives for merging or diverting, vertical switch points, lifters, and sorters
- ▶ Quiet operation for acoustically sensitive areas

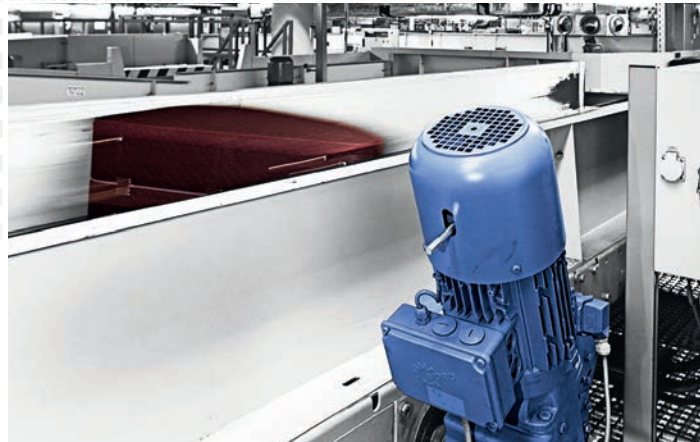

With specialized expertise in airport conveyor technology, NORD creates economical drive solutions that meet all current and future requirements - effectively powering conveyor systems to keep baggage systems continuously in motion from one end of the airport to the other.

NORD DRIVESYSTEMS is recognized in the airport industry by renowned international consultants and operators.



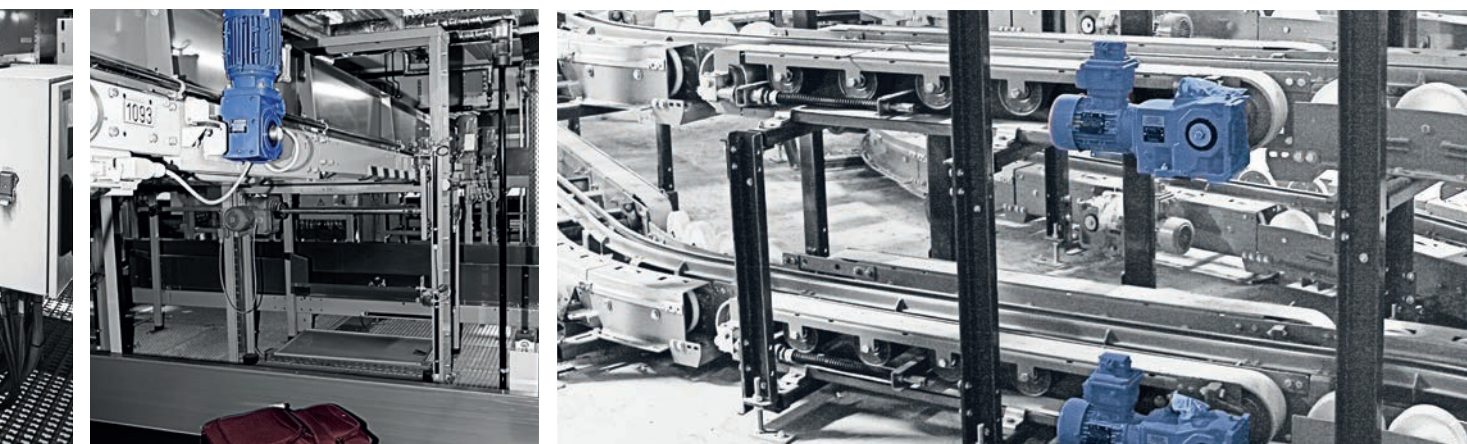
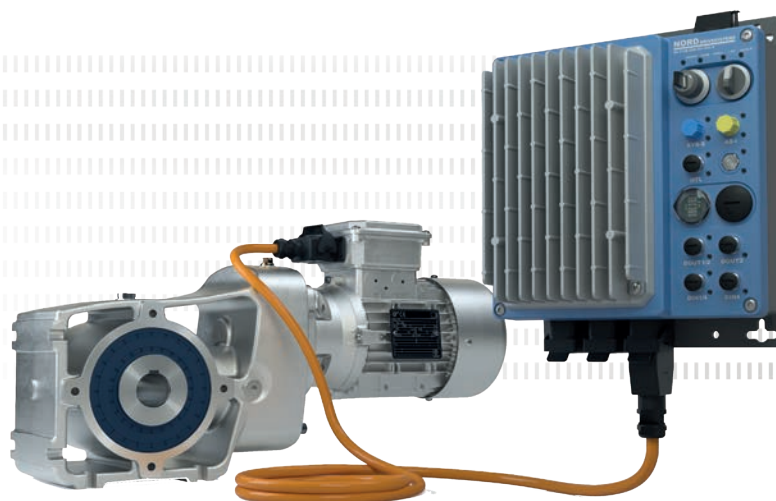

NORD supports you with the following:

Design

- ▶ myNORD online tools
- ▶ Variant reduction options
- ▶ Project design/optimization
- ▶ Drive design
- ▶ Application solutions
- ▶ Green solutions
- ▶ CAD drawings
- ▶ TCO/ROI calculations
- ▶ Efficiency optimization

Commissioning

- ▶ Plug-and-play
- ▶ Support
- ▶ Training
- ▶ Documentation
- ▶ Smart commissioning

Service

- ▶ Predictive maintenance (PLC function)
- ▶ Spare parts, express shipping
- ▶ Global service and support
- ▶ 24/7/365 emergency support

Drive solutions for baggage handling systems

For condition monitoring, operating and status data are regularly or continuously recorded in order to optimize the reliability and efficiency of facilities and machinery. Important information for predictive maintenance can be derived from data analysis.

The objective is to maintain machines and facilities proactively, reducing downtimes and increasing overall operational efficiency.

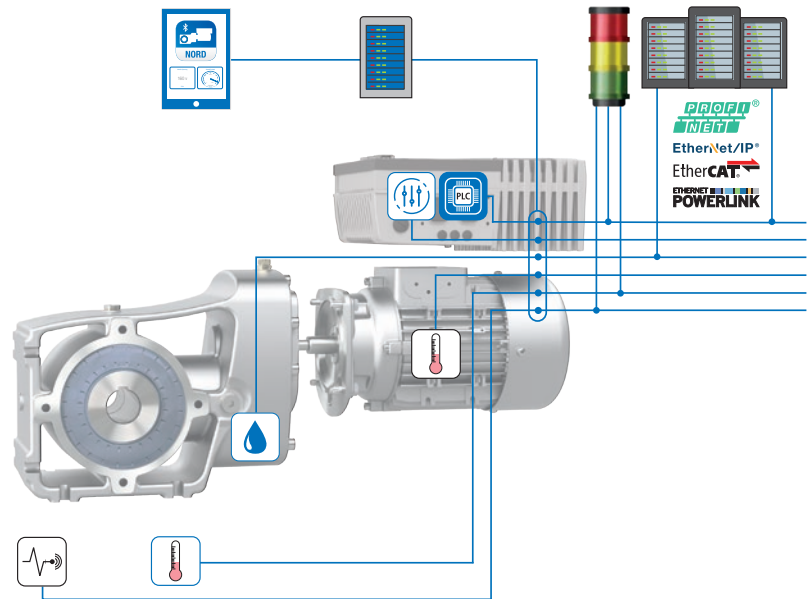



- System vibration sensor 

 - ▶ NORD qualified sensors
 - ▶ Customer-specific sensors can be connected (analog/digital)
- Temperature sensor 

 - ▶ Motor temperature sensor on the basis of PT1000
 - ▶ Ambient or system temperature
- Oil change 

 - ▶ Determination of the optimum time for oil change on the basis of the virtual oil temperature
 - ▶ Algorithm is executed in the internal PLC
- Drive parameters 

 - ▶ Read-out of the drive parameters of the drive system
 - ▶ Basis for virtual sensors
- Integrated PLC 

 - ▶ Pre-processing of drive-specific parameters and drive-related sensors
 - ▶ Evaluation of drive condition
- Signal beacon 

 - ▶ Local display of drive condition
 - ▶ Scalable display
- Local data management 

 - ▶ Processing of drive data for drive and system analysis
 - ▶ Condition monitoring
- Local dashboard 

 - ▶ Display of drive and system data
- Higher level PLC 

 - ▶ Processing of condition monitoring information by the customer
 - ▶ Combination of the collected condition monitoring data with the process data

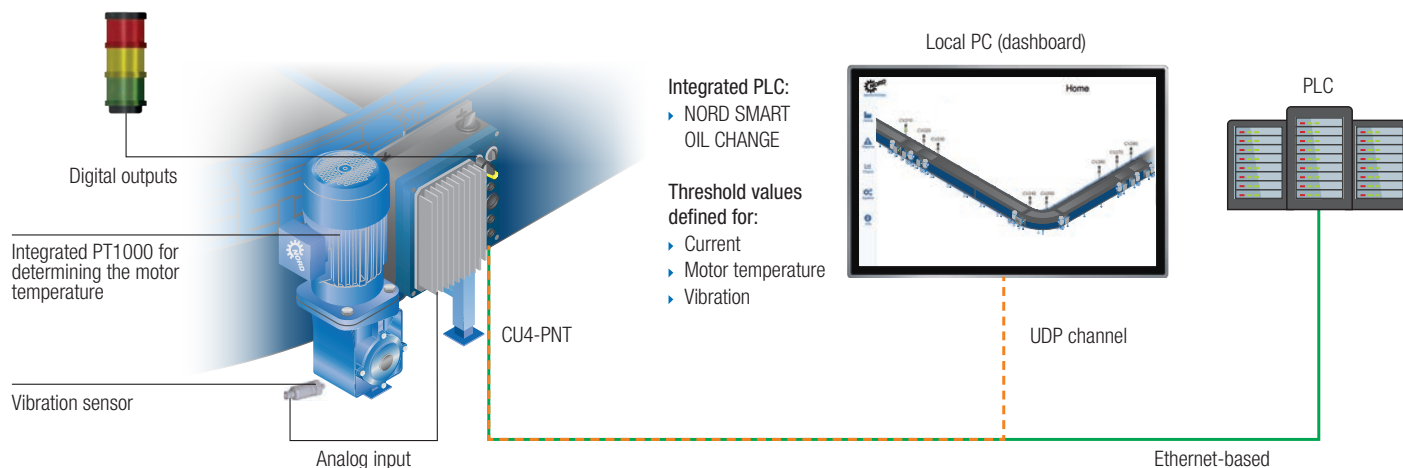

Condition monitoring at an airport

At an international airport, NORD DRIVESYSTEMS has retrofitted a pilot system in order to collect condition monitoring data from selected drives. The conveyors within the system are equipped with NORD gear units, motors, and NORDAC *LINK* variable frequency drives.

The motors feature a PT1000 to determine the motor temperature. A vibration sensor attached to each gear motor monitors the vibration velocity of the drive. Both sensors are analog sensors and thus could be connected directly to the analog inputs of the NORDAC *LINK*.

This solution's special feature is that the NORD VFD's integrated PLC is used to evaluate threshold values for vibration, motor temperature, and motor current, as well as generate corresponding warning and alarm messages based on that data. In addition, the NORD SMART OIL CHANGE algorithm runs within the integrated PLC to determine the oil change interval of the 2-stage bevel gear units.

In this application, the complete logic for the NORD Condition Monitoring for Predictive Maintenance solution has been implemented within the variable frequency drive's integrated PLC.

Additionally, a communication interface to the higher level PROFINET IO controller is in use. Via the PROFINET IO interface, several drive info parameters are transferred to a PC. With its touch screen, the PC also serves as NORD's dashboard where the values that have been stored in a local database can be displayed. Messages on exceeded threshold values, as well as general drive information parameters can easily be displayed here. Data from the past can also be displayed quickly and easily via a history function.

An external signal beacon light, connected and supplied via the NORDAC *LINK*, is also a part of this system. It provides a visual queue for the condition monitoring status. Green – no messages, Orange – warning threshold exceeded, Red – alarm threshold exceeded. Warning or alarm messages that have occurred can also be directly acknowledged via a reset button on the dashboard.

This solution allowed for existing gear units to be modified to provide condition monitoring for predictive maintenance functionality, making the transition to this proactive maintenance solution very cost effective.

Drive solutions for baggage handling systems



Intelligent drives from NORD DRIVESYSTEMS play an important role in highly networked systems to advance the so-called fourth industrial revolution which is based on extensive exchange of information on all levels to increase efficiency and prevent costly downtime.

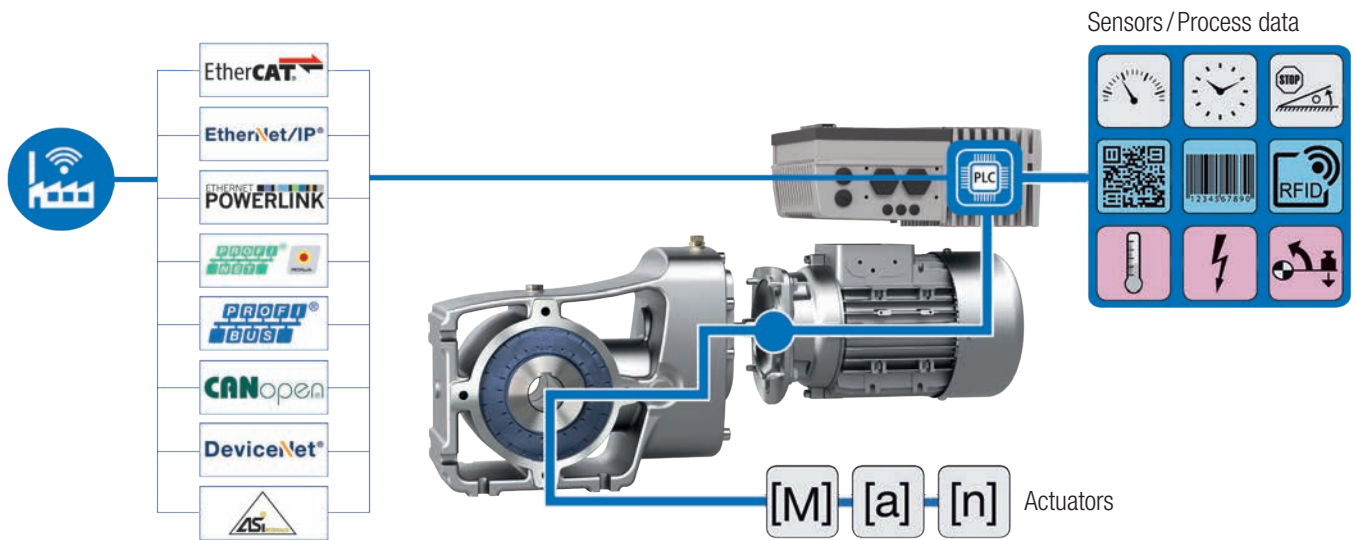

NORD DRIVESYSTEMS – INDUSTRY 4.0 READY!

“NORD 4.0 READY!” means that NORD drives are networked, autonomous, and scalable. The key to this are NORD’s variable frequency drives with their powerful processors, comprehensive equipment, interfaces, and functions. They not only monitor the VFD and motor conditions, but also the driven load. The integrated PLC processes data from sensors and actuators and if necessary, initiates a control sequence to communicate high quality drive and application data to the control center and other networked components.

For example, intelligent sequence controls can enable the drive unit to locally determine what actions are required. The drive units can also coordinate with each other: “Attention, I am sending a package in your direction. Start your conveyor belt.” A follower drive can synchronize to a master for a particular task and then return to normal operation. Hundreds of typical functions are saved as unique parameter sets and can be easily adopted.

As a result, the variable frequency drive can coordinate both simple and complex applications independently from the plant control system, and can respond to changes to the process or remedy many process faults without external intervention.

The new DuoDrive with integrated IE5+ synchronous motor delivers a new era of energy efficiency and easy system maintenance.

- ▶ Extremely high system efficiency of up to 92%
- ▶ Reduced Total Cost of Ownership (TCO) and fast Return on Investment (ROI)
- ▶ Variant reduction through constant motor torque over a wide speed range
- ▶ Compact, wash-down design for easy installation and optimized space utilization
- ▶ Industry-standard mounting dimensions
- ▶ Quiet operation

Features

- ▶ Latest generation permanent magnet synchronous motor (PMSM) integrated in a single-stage helical in-line gear unit housing
- ▶ Power range from 0.5 to 4 hp in a single frame size
- ▶ Flexible attachment options:
 - ▶ B5 flange (160 mm diameter)
 - ▶ B14 flange (160 or 200 mm diameter)
 - ▶ Torque arm, shrink disc, and GRIPMAXX™
- ▶ Wide variety of motor connectivity options such as HANQ8 / HAN10E plug connectors, circular connectors, or directly wired
- ▶ Optional holding brake and integrated encoder system

Perfect system solution combined with NORD drive electronics

- ▶ NORDAC *PRO* for control cabinet installations, NORDAC *LINK*, *FLEX*, and *ON+* for decentralized and wall mounting installations
- ▶ Suitable system wiring:
 - ▶ Motor connection
 - ▶ Mains supply
 - ▶ Signal connection
- ▶ Together with perfectly matched drive electronics, NORD DuoDrive is the perfect solution for high power requirements and outstanding system efficiency

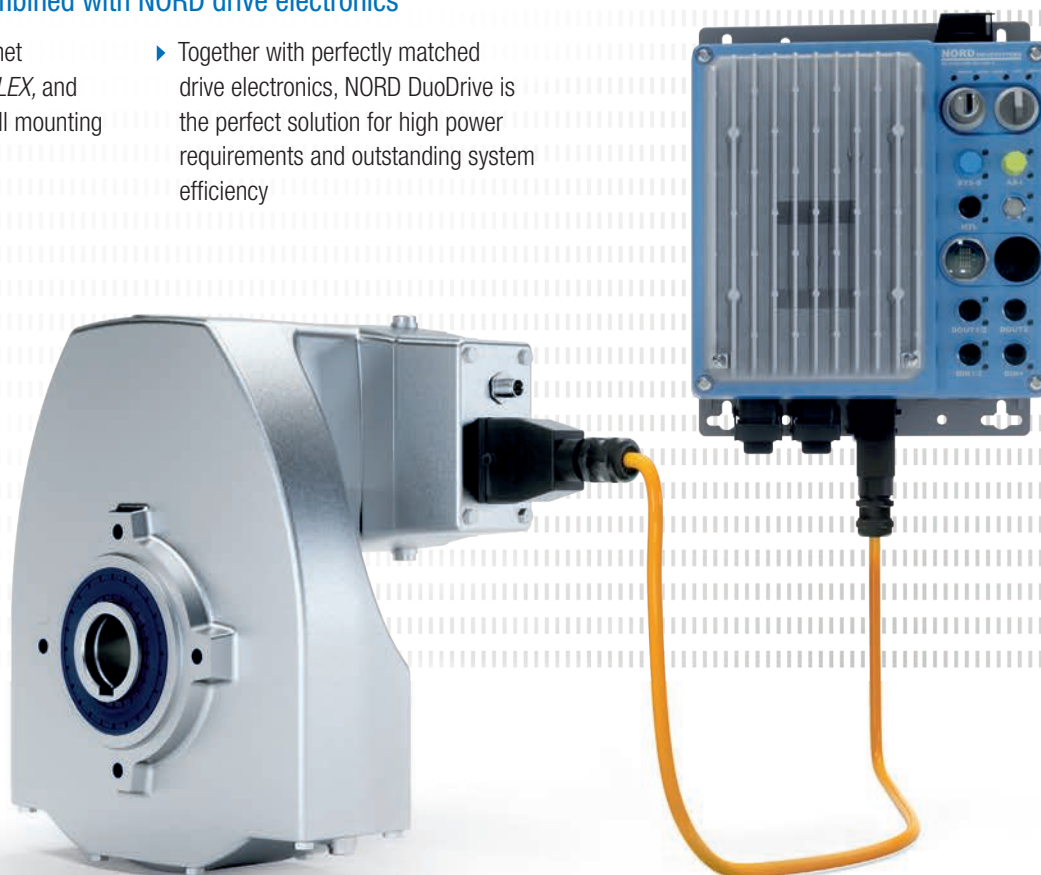

Drive solutions for baggage handling systems

LogiDrive®

The ideal solution for logistics applications

- ▶ High efficiency 2-stage bevel gear unit
- ▶ IE4 or IE5+ PMSM synchronous motor
- ▶ Decentralized variable frequency drive
- ▶ Power plug connector
- ▶ M12 - slots
- ▶ Incremental encoder
- ▶ Pre-assembled cable
- ▶ High overload capability
- ▶ Standardized hollow shaft diameter

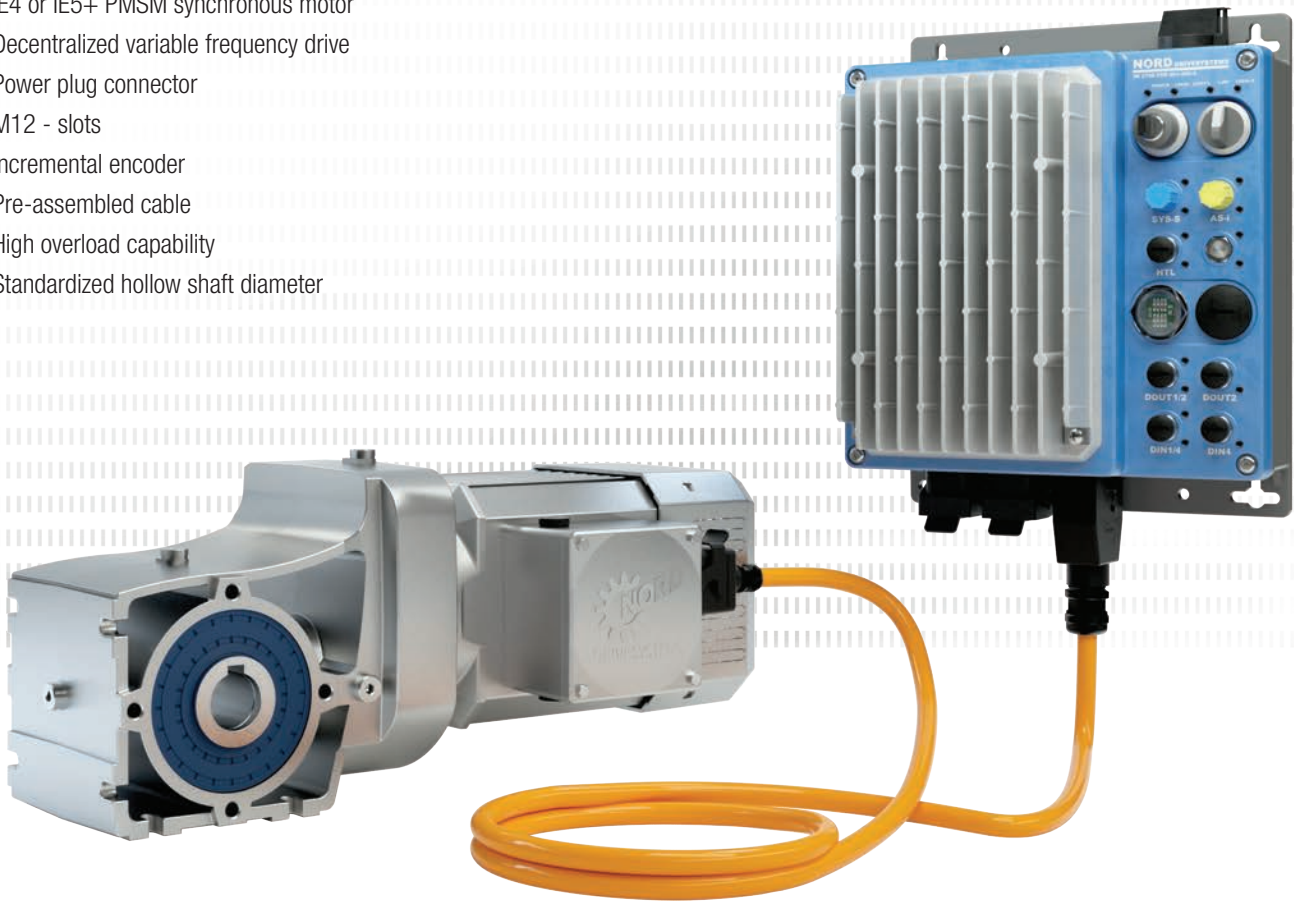

The LogiDrive solution from NORD DRIVESYSTEMS reduces planning and commissioning effort

- ▶ NORD VFDs for intralogistics and airport applications can control both synchronous and asynchronous motors
- ▶ Simple planning with identical housing dimensions for synchronous and asynchronous motors

Motor size	IE3	IE5+
71	0.33 - 0.5 hp	0.5 - 3.0 hp
80	0.75 - 1.0 hp	0.5 - 3.0 hp
90	1.5 - 2.0 hp	1.5 - 4.0 hp
100	3.0 - 4.0 hp	1.5 - 5.0 hp

Efficiency maintained at partial loads and low speeds

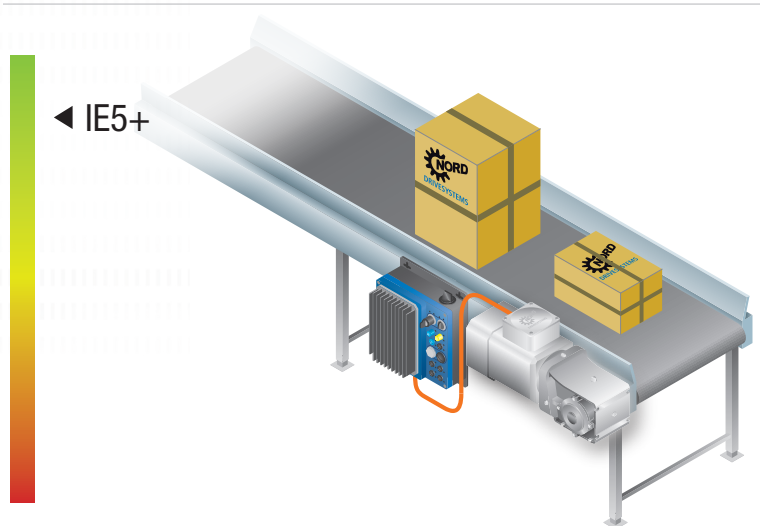
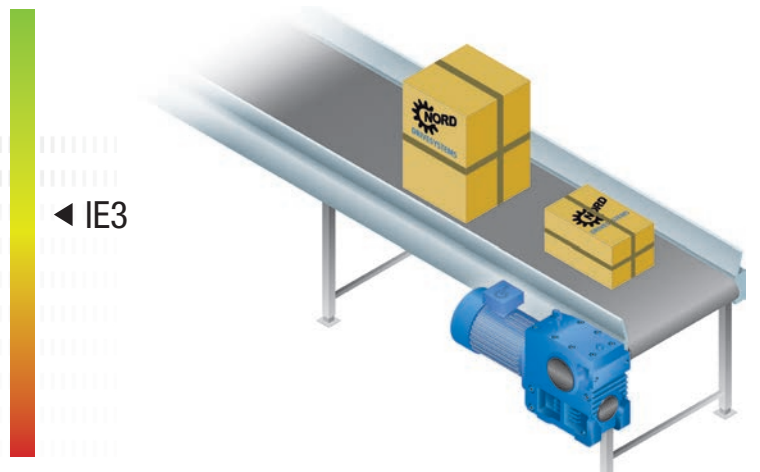

NORDAC LINK FDS* SK 250 *field distribution system

- ▶ Internal or external braking resistor
- ▶ External 24 VDC supply for the control board, this ensures the same potential for all drive units. The drive units can be accessed via the bus even without the 400 VAC main voltage, as the control board remains active due to the 24 VDC supply.
- ▶ Decentralized installation
- ▶ Plug-in VFD
- ▶ Plug-in EEPROM, data can be transferred if servicing is required

Total Cost of Ownership (TCO)

IE5+ synchronous motors unfold their full potential in applications with partial load and low speed ranges. By using IE5+ synchronous motors, airports can achieve significant cost reductions and increased operational efficiency.

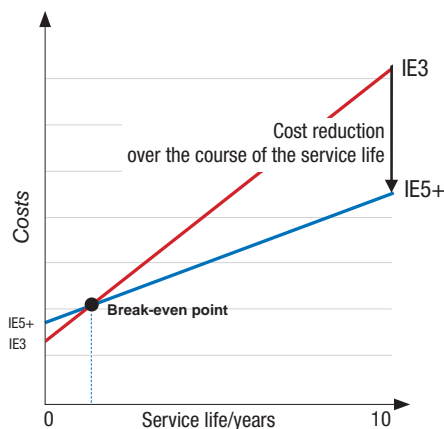

The use of IE5+ synchronous motors minimizes costs throughout service life, achieves considerably greater efficiency, and provides a fast return on investment (ROI).

IE5+ means energy efficiency

- ▶ Meets or exceeds highest efficiency standards
- ▶ Significantly reduces TCO
- ▶ PMSM technology provides consistent efficiency even at partial load and low speed ranges



Drive solutions for baggage handling systems

UNICASE™ helical inline gear units (Catalog G1000)



- ✓ Foot or flange mounted
- ✓ Long life, low maintenance
- ✓ Optimum sealing
- ✓ UNICASE housing

Sizes: 11
 Power: 0.16 – 215 hp
 Torque: Up to 230,000 lb-in
 Ratio: 1.35 – 14,340.31:1

CLINCHER™ parallel shaft gear units (Catalog G1000)



- ✓ Foot, flange, or shaft mounted
- ✓ Hollow or solid shaft
- ✓ Compact design
- ✓ Cast-iron or aluminum UNICASE housing

Sizes: 15
 Power: 0.16 – 268 hp
 Torque: Up to 885,075 lb-in
 Ratio: 4.03 – 15,685.03:1

NORDBLOC.1® 2-stage helical gear units (Catalog G1014)

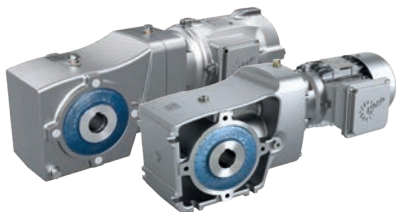

- ✓ Foot, flange, or shaft mounted
- ✓ Hollow or solid shaft
- ✓ Aluminium housing
- ✓ Compact design

Sizes: 6
 Power: 0.16 – 12.5 hp
 Torque: Up to 5,800 lb-in
 Ratio: 3.03 – 70:1

FLEXBLOC® worm gear units (Catalog G1035)



- ✓ Modular aluminum housing
- ✓ Universal mounting design
- ✓ Life-long lubrication
- ✓ NEMA or IEC input versions

Sizes: 5
 Power: 0.16 – 5.5 hp
 Torque: Up to 3,779 lb-in
 Ratio: 5.00 – 3,000:1

Motors (Catalog M7000)



- ✓ IE3 motors from 0.16 hp (Size 63)
- ✓ IE5+ synchronous and asynchronous motors

International energy efficiency standards

- ▶ EU: IE1 – IE5+ as per IEC 60034-30
- ▶ US: ee labelling as per EISA 2007 (Dept. of Energy)
- ▶ CA: CSA energy verified as per EER 2010
- ▶ CN: CEL as per GB 18613
- ▶ KR: KEL as per REELS 2010
- ▶ BR: Alto Rendimento as per Decreto nº 4.508
- ▶ AU: MEPS as per AS/NZS 1359.5

NORDAC® ACCESS BT (Catalog E3000)



- ✓ Stand-alone parameter memory
- ✓ Bluetooth interface for VFDs and NORDCON APP
- ✓ Data transfer to PC via USB
- ✓ Can be plugged in or disconnected during operation

DuoDrive – integrated gear unit (Catalog G5010)



- ✓ High-efficiency IE5+ synchronous motor
- ✓ System efficiency of up to 92%
- ✓ Can significantly reduce TCO (Total Cost of Ownership) compared to other drive systems
- ✓ High power density
- ✓ Quiet operation
- ✓ Simple plug-and-play commissioning
- ✓ Hygienic wash-down design
- ✓ Mounting optionsn M1, M5, M6

Sizes: 2
 Power: 0.5 – 4 hp
 Torque: Up to 2,186 lb-in
 Ratio: 3.24 – 18.1:1

NORDAC® ON/ON+ variable frequency drives (Catalog E3000)



- ✓ Wall or motor mounted
- ✓ Integrated Ethernet communication
- ✓ Compact design
- ✓ Plug-and-Play solution

NORDAC *ON*
 Sizes: 3
 Voltage: 3 ~ 460 V
 Power: 0.25 – 3.5 hp

NORDAC *ON+*
 Sizes: 3
 Voltage: 3 ~ 460 V
 Power: 0.25 – 4 hp

NORDAC® START SK135E motor starters (Catalog E3000)



- ✓ Integrated electronic brake rectifier
- ✓ Consistent parameter structure
- ✓ Reversing starter with soft start function

Sizes: 2
 Voltage: 3 ~ 200 – 240 V, 3 ~ 380 – 500 V
 Power: 0.16 – 4 hp or up to 10 hp

NORDAC® FLEX SK200E variable frequency drives (Catalog E3000)



- ✓ Energy saving function
- ✓ Integrated POSICON positioning control
- ✓ Integrated PLC

Sizes: 4
 Voltage: 1 ~ 110 – 120 V, 1 ~ 200 – 240 V, 3 ~ 200 – 240 V, 3 ~ 380 – 500 V
 Power: 0.33 – 30 hp

NORDAC® LINK SK250E field distributors (Catalog E3000)



- ✓ Variable frequency drive or motor starter
- ✓ All connections in plug-in version for easy commissioning and maintenance
- ✓ PLC functionality for drive-integrated functions

Sizes: 2
 Voltage: 3 ~ 380 – 500 V
 Power: VFD 0.75 – 10 hp, Motor starter 0.16 – 4 hp

Ordering is Easy With myNORD Online Tools!

- ▶ Obtain drawing files direct from quote configuration
- ▶ Effortlessly select & configure customized drive solutions
- ▶ Create quotes with account-specific net pricing
- ▶ Order-specific documentation
- ▶ 24/7/365 order tracking
- ▶ Select and order spare parts



Register now at myNORD.com!



US

NORD Gear Corporation
 Waunakee, WI
 800 NORD Drive
 Waunakee, WI 53597
 Tel. 888.314.6673
info.us@nord.com
www.nord.com

Corona, CA
 1180 Railroad St.
 Corona, CA 92882
 Tel. 888.314.6673
info.us@nord.com

Charlotte, NC
 300E Forsyth Hall Dr.
 Charlotte, NC 28273
 Tel. 888.314.6673
info.us@nord.com

CA

NORD Gear Limited
 Brampton, ON
 41 West Drive
 Brampton, ON L6T4A1
 Tel. 800.668.4378
info.ca@nord.com

MX

NORD DRIVE SYSTEMS SA DE CV
 Queretaro, Mexico
 Av. Industria Textil B.6
 Parque Industrial PYME, Huimilpan
 QRO - Mexico 76950
 Tel. 52 442 688 7110
info.mx@nord.com